

# UNIT -1:

## WAVE MOTION AND ITS APPLICATIONS

### 7.1 WAVEMOTION

Motion of an object is the change in its position with time. In different types of motions, some form of energy is transported from one place to another. There are two ways of transportation of energy from its place of origin to the place where it is to be utilized. One is the actual transport of matter. For example when a bullet is fired from a gun it carries kinetic energy which can be utilized at another place. The second method by which energy can be transported is the wave process. A wave is the disturbance in which energy is transferred from one point to other due to repeated periodic motion of particles of the medium. The waves carry energy but there is no transport of matter.

There are two types of waves;

1. Mechanical or Elastic waves
2. Electromagnetic waves

#### **Mechanical waves**

Those waves which are produced due to repeated periodic motion of medium particles are called mechanical or elastic waves. They need a material medium for their generation and propagation. For example sound waves, water waves are mechanical in nature.

#### **Electromagnetic wave (Light)**

The wave which travels in form of varying electric and magnetic fields mutually perpendicular to each other and also perpendicular to direction of propagation of wave. They do not need material medium for their propagation. For example, light waves, heat radiations, radio waves, X-rays are electromagnetic waves.

*The propagation of disturbance through a medium due to repeated periodic motion of medium particles is called wave motion.*

The characteristics of wave motion are:

1. The wave travels forward but the particles vibrate only about their mean position.
2. The velocity of propagation is the rate at which the disturbance travels through the medium.

3. The velocity of the wave depends on the type of wave (light, sound) and type of medium (air, water, or metal).
4. The velocity of waves is different from the velocity of particles.
5. There is a regular phase difference between particles of a wave.

**Types of Wave Motion:** There are two types of wave motion;

- a) Transverse wave motion
- b) Longitudinal wave motion

**a) Transverse wave motion**

When the particles of the medium vibrate perpendicular to the direction of propagation of wave the wave motion is called transverse wave motion. A transverse wave motion is shown in Fig. 7.1. A transverse wave consists of one crest and one trough that makes one cycle. The distance between two consecutive crests or two consecutive troughs is called wave length. The farthest point in positive direction is called crest and that in negative direction is called trough.

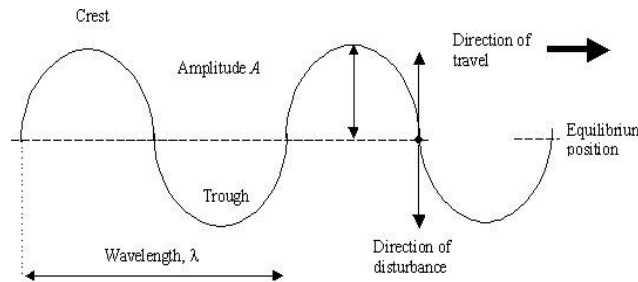
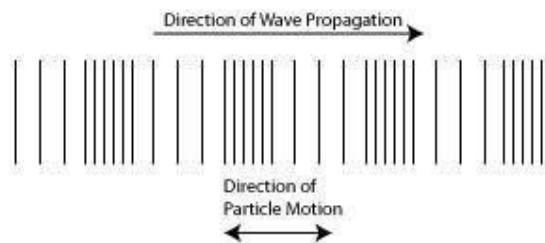

**Fig.7.1**

Examples are wave produced by a stretched string, light waves, waves produced on surface of water etc.

**b) Longitudinal Waves**

When the particles of medium vibrate parallel to the direction of propagation of wave the wave motion is called longitudinal wave motion. A longitudinal wave travels in the form of compressions and rarefactions as shown in the Fig. 7.2. The part of medium where distance between medium particles is less than their normal distance is called compression and the portion where distance is more than their normal distance is called rarefaction. One cycle consist of one complete compression and one complete rarefaction. The distance between two consecutive compressions and rarefaction is called wave length.



**Fig.7.2**

Most familiar example of longitudinal waves is sound waves. Sound waves can travel in medium such as solids, liquids and gases.

The main points of difference between transverse and longitudinal waves are listed below:

| S.No. | Transverse Waves  | Longitudinal Waves   |
|-------|---|--|
| 1.    | The particles of the medium vibrate perpendicular to the direction of propagation of wave | The particles of medium vibrate parallel to the direction of propagation of wave |
| 2.    | The wave travels in form of crests and troughs  | The wave travels in form of compressions and rarefactions.                       |
| 3.    | There is no change in density of the medium.  | These waves produce change in density of the medium.                             |
| 4.    | These waves can be polarised.   | These waves cannot be polarised.   |
| 5.    | Electromagnetic waves, wave travelling on stretched string, light waves are the examples. | Sound waves, pressure waves, musical waves are its examples.                     |

### Terms Characterizing Wave Motion:

Various parameters used to characterize a wave motion are defined below.

**Displacement:** The distance of a particle from its mean position, at any instant is called displacement.

**Amplitude:** It is the maximum displacement of the particle from its mean position of rest.

**Wavelength:** It is the distance travelled by the wave in the time in which the particle of the medium completes one vibration.

It is denoted by  $\lambda$  and measured in metres. The distance AB or DE in figure 7.3 is equal to one wave length.

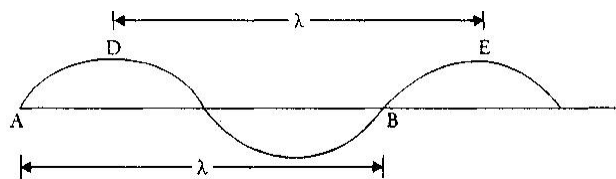

Fig.7.3

**Time period:** It is defined as the time taken by a wave to complete one vibration or one cycle. It is denoted by (T) and S.I. unit is second.

**Frequency:** The number of vibrations made by a wave in one second is called frequency. It can also be written as reciprocal of time period ( $\nu = 1/T$ ).

It is represented by  $\nu$  and units are Hertz (Hz), KiloHertz (KHz), MegaHertz (MHz) ...etc.

**Wave Velocity:** The distance travelled by the wave per unit time is defined as wave velocity. It is denoted as  $(V)$  and measured in m/s.

**Phase:** Phase of a vibrating particle tells the position of a particle at that instant. It is measured by the fraction of angle or time elapsed by wave at any instant since the particle has **crossed its mean position in positive direction. It is denoted by  $\theta$**  and unit is radian.

**Phase difference:** The difference in angle or time elapsed between two particles at any instant. It is calculated by the formula

$$\text{Phase difference} = \frac{2\pi}{\lambda} \times \text{path difference}$$

### Relation between Wave velocity, Wavelength and Frequency

Wave velocity is the distance travelled by a wave in one time period.

$$V = \frac{\text{Distance} = \lambda}{\text{Time } T}$$

and frequency is reciprocal of time period i.e.

$$v = \frac{1}{T}$$

Thus  $V = v\lambda$

The relation holds for both transverse and longitudinal waves.

**Numerical 1:** A radio station broadcasts at a frequency of 15 MHz. The velocity of transmitted waves is  $3 \times 10^8$  m/s. What is the wavelength of transmitted waves?

**Solution:** Given, frequency ( $\nu$ ) = 15 MHz =  $15 \times 10^6$  Hz, Velocity of waves ( $V$ ) =  $3 \times 10^8$  m/s

Using relation;  $V = v\lambda$

$$\text{we get wavelength } (\lambda) = \frac{V}{v} = \frac{3 \times 10^8}{15 \times 10^6} = 20 \text{ m}$$

**Numerical 2:** A tuning fork of frequency 512 Hz makes 24 vibrations in air. If velocity of sound in air is 340 m/s, how far does sound travel in air?

**Solution:** Here, frequency ( $\nu$ ) = 512 Hz and velocity = 340 m/s Using the relation  $V = v\lambda$ , we get

$$\text{Wavelength } (\lambda) = \frac{V}{v} = \frac{340}{512} \times 24 = 0.664 \text{ m}$$

Therefore, distance in 24 vibrations =  $24 \times \lambda = 24 \times 0.664 \text{ m} = 15.94 \text{ m}$

## 7.2 FREE, FORCED AND RESONANT VIBRATIONS

### Vibrations

A motion in which the object moves to and fro about a fixed mean position is called oscillatory motion (vibration). All oscillatory motion needs to be periodic. The motion in which the object repeats its path after a fixed regular interval of time is called periodic motion. For example, motion of hands of clock, motion of spring mass system, simple pendulum, cantilever, rim of cycle wheel etc.

Whenever there are vibrations, there is transfer of energy which makes a wave. An understanding of vibrations and waves is required to understand our physical world. We see around us because of light waves and we hear the world around us because of sound waves.

**Types of Vibrations:** There are three types of vibrations: free, forced and resonant.

**1) Free Vibrations:** A force can set a resting object into motion. But when the force is a short-lived or momentary, it only begins the motion. The object moves back and forth, repeating the motion over and again.

*When a body is set into vibrations and is allowed to vibrate freely under the influence of its own elastic forces such vibrations are called free vibrations.*

The frequency of vibration is called natural frequency. Examples are vibrations of simple pendulum, cantilever, loaded beam etc.

Free vibrations can also be divided into two classes; damped and undamped vibrations.

**a) Damped Vibrations:** In case of free vibrations, the extent of displacement from the equilibrium position reduces with time. This is because the force that started the motion is a momentary force and the vibrations ultimately cease. The object is said to experience damping. Thus when the amplitude of vibrations goes on decreasing with time and finally the vibrations stop after some time then such vibrations are called damped vibrations as shown in Fig.7.4. For example vibrations of cantilever, loaded beam, spring mass system etc. Damping is the tendency of a vibrating object to lose or to dissipate its energy over time. The mechanical energy of the object is lost to other objects. Without a sustained forced vibration, the back and forth motion of the object eventually ceases as energy is dissipated to other objects.

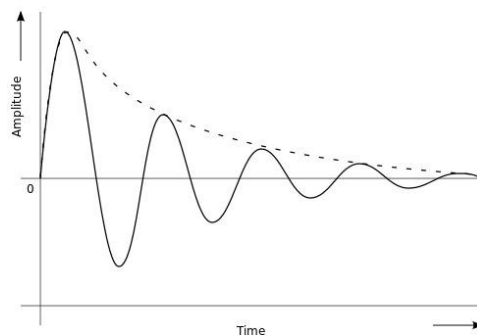

**Fig.7.4.** Damped vibrations

**b) Undamped Vibrations:** If the amplitude of vibrations remains constant and the vibrations continue for infinite time then such vibrations are called undamped vibrations as shown in Fig. 7.5. For example vibrations of simple pendulum in a closed glass box.

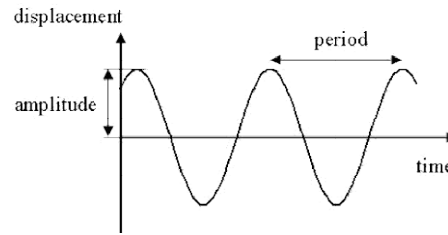

**Fig.7.5.**Undamped vibrations

- 2) **Forced Vibrations:** A vibrating object naturally loses energy with time. It must continuously be put back into the vibrations through a force in order to sustain the vibration. A sustained input of energy would be required to keep the back and forth motion going. Thus *when a periodic force is used to maintain the vibrations of an object then such vibrations are called forced vibrations*. For example swing of a child.
- 3) **Resonant Vibrations:** *It is a special type of forced vibration in which the frequency of applied force matches with natural frequency of an object.* In this situation resonance occurs and the amplitude of vibrations increases largely. For example tuning of radio set, swing of a child.
  - (a) Tuning of a radio set: There are many stations sending radio waves of various frequencies causing forced oscillations in the circuit of receiver. When the frequency of tuner equals that of waves from particular broadcasting station, the resonance takes place and hence we can hear only that station, whose amplitude is increased.
  - (b) Another example is swing of a child, which acts as a pendulum. The force with a frequency that matches with the natural frequency of the swing (its resonant frequency) makes the swing go higher and higher (maximum amplitude), while attempts to push the swing at a faster or slower rate produce smaller amplitude. This is due to the fact that swing absorbs maximum energy when the force matches with natural frequency of swing.

Resonance occurs widely in nature. Some sounds we hear, like when hard objects of metal, glass, or wood are struck, are caused by brief resonant vibrations in the object. Electromagnetic waves are produced by resonance on an atomic scale. Other examples are the balance wheel in a mechanical watch, tidal resonance, acoustic resonances of musical instruments, production of coherent light by optical resonance in a laser etc.

### 7.3 SIMPLE HARMONIC MOTION (SHM)

It is a special type of motion in which the restoring force is directly proportional to displacement from the mean position and opposes its increase. Applying Newton's second law of motion (force = mass  $\times$  acceleration), it can be stated as ***a periodic motion in which the acceleration is directly proportional to displacement and is always directed towards mean position.***

In other words, if  $F$  is the restoring force and 'y' is the displacement from the mean position, then

$$F = -K y \quad \text{or} \quad a = -\frac{K}{m} y$$

The negative sign indicates that  $F$  opposes increase in  $y$  and  $K$  is constant of proportionality, called force constant. In such motion displacement varies harmonically with time and can be represented in terms of harmonic functions i.e.  $\sin\theta$ ,  $\cos\theta$  such as

$$y(t) = A \sin \omega t \text{ or } A \cos \omega t \quad (\theta = \omega t)$$

Here  $A$  is the amplitude of SHM and is the **maximum value of displacement from the mean position** and  $\omega$  is angular frequency.

### Characteristics of SHM:

- The motion should be periodic.
- Force causing the motion is directed toward the equilibrium point (minus sign).
- Acceleration produced is directly proportional to the displacement from equilibrium.

Under the influence of a restoring force ( $F$ ), a body acquires a velocity  $\left(\frac{dy}{dt}\right)$  and hence an

acceleration  $\left(\frac{d^2y}{dt^2}\right)$ . This can be written as

$$\text{Acceleration} = -\frac{K}{m} y$$

or 
$$\frac{d^2y}{dt^2} = -\omega^2 y \quad ; \quad \omega = \sqrt{\frac{K}{m}}$$

Term  $\omega$  is called angular frequency which is  $2\pi$  times the frequency ( $\nu$ ). Frequency ( $\nu$ ) is measured in cycles per second (cps) or Hertz (Hz) and  $\omega$  in radians/sec.

$$\omega = 2\pi\nu = \frac{2\pi}{T}$$

$T$  is the time period of the motion (smallest time interval after which a motion repeats itself) and is given by

$$T = \frac{2\pi}{\omega} = 2\pi \sqrt{\frac{m}{K}}$$

Examples of SHM are; motion of simple pendulum, cantilever, mass-spring system, swing etc.

## 7.4 CANTILEVER

A metallic beam fixed at one end and free to vibrate at the other end is called cantilever. The normal configuration of a cantilever is shown in Fig. 7.6.

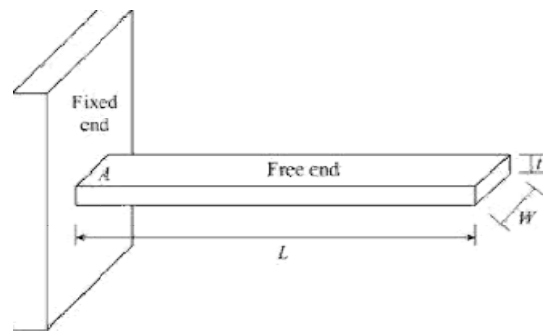

**Fig.7.6** ACantilever

When it is loaded at free end it vibrates and its edge performs simple harmonic motion. The time taken to complete one vibration is called time period.

The time period is given by

$$T = 2\pi \sqrt{\frac{p}{g}}$$

Where  $p$  is the depression of beam (displacement of beam from its unloaded position) and  $g$  is acceleration due to gravity.

## 7.5 SOUND WAVES

These are mechanical waves and need medium for their propagation. Sound waves also called pressure waves can be transmitted through solid, liquid or gas. There are three frequency ranges in which sound is categorised:

- a) **Audible:** These sound waves between frequencies 20 Hz to 20 kHz is audible to human ears and is called audible range.
- b) **Infrasonic:** Sound waves below frequency 20 Hz are called infrasonic and are inaudible to human ears. A number of animals produce and use sounds in the infrasonic range. For example elephant, whales, rhinos etc.
- c) **Ultrasonic:** The sound waves with frequency above 20 kHz are called ultrasonic. Bats communicate through ultrasonic waves. They are also inaudible to human ears.

### Properties of sound waves are:-

1. Sound waves are longitudinal mechanical waves.
2. They need material medium for their generation and propagation.
3. They cannot travel through vacuum so their velocity in vacuum is zero.
4. Their velocity in air at NTP is 332 m/s and it increases with rise in temperature.
5. Sound waves travel faster in solids than in liquids than in gases.
6. They show the phenomena of reflection, transmission, diffraction etc.

## 7.6 ACOUSTICS OF BUILDINGS

The branch of physics that deals with study of audible sound including their generation, propagation and properties is called acoustics.

**Acoustics of buildings:** It deals with construction of public halls, auditoriums, cinema halls etc. for best sound effects.

**Generation of Audible Sound:** Any object that can produce longitudinal mechanical waves of frequency between 20 Hz to 20 KHz generates audible sound. For example, musical instruments, vibrating fork, human throat (vocal chord) etc.

**Propagation of Audible Sound:** Audible sound propagates in material medium only. Its velocity is lowest in air and increases with increase in density of the medium. It travels fastest in metals. While travelling in one medium if it meets another medium it gets divided into three parts; reflected part, absorbed part and transmitted part.

### **Coefficient of Absorption of Sound:**

The ratio of sound energy absorbed by a surface to the total sound incident on a surface is called coefficient of absorption or simply absorption coefficient of sound. It is denoted by 'a' and its SI unit is OWU (Open window unit). Its value is maximum (=1) for an open window.

$$a = \frac{\text{absorbed sound energy by a surface}}{\text{Total sound energy incident on the surface}}$$

**Types of Audible Sound:** Two types of audible sound are musical sound and noise.

**Musical Sound:** The sound that produces pleasant effect on our ears is called musical sound. It is a single sound or multiple sounds having same frequency, wavelength and meeting in same phase.

**Noise:** The sounds that produce unpleasant effect on our ears are called noise. It has irregular amplitude with time. It is generally a combination of multiple sounds of different frequency, wavelength and meeting in different phases.

### **Reverberation:**

It is the persistence of sound after the source has stopped emitting sound due to reflection from multiple surfaces.

### **Reverberation Time:**

The time up to which a sound persists in a hall or room after the source has stopped emitting it is called reverberation time.

**Standard reverberation time (Sabine's formula):** Reverberation time is the time taken by the sound intensity to drop by 60 dB or reduce to its one millionth parts. An American scientist W. C. Sabine developed an equation for calculating the reverberation time as:

$$T = \frac{0.16V}{\sum a \times S}$$

where V is the volume of the hall in m<sup>3</sup>, a is the average absorption coefficient of room surfaces and S is total surface area of room in m<sup>2</sup>.

$$\text{Here } \sum aS = a_1s_1 + a_2s_2 + a_3s_3 + \dots$$

where a<sub>1</sub>, a<sub>2</sub>, a<sub>3</sub> etc. are absorption coefficients of different objects in hall and s<sub>1</sub>, s<sub>2</sub>, s<sub>3</sub> etc. are their surface areas.

### **Echo:**

The repetition of original sound by reflection from a surface is called echo. The echo is produced if the reflected sound reaches our ears after 1/10 of a second. It is different from reverberation as echo is identified as repeated sound due to a time gap of at least 1/10 of a second.

The distance 'd' of reflector/obstacle causing echo is given by

$$d = \frac{V \cdot t}{2}$$

where 'V' is velocity of sound and 't' is time taken by reflected sound to reach our ears.

The minimum distance of obstacle to produce echo thus is given as s =

$$\{332 \times (1/10)\} / 2 = 16.6 \text{ m/s}$$

Thus, the obstacle must be placed at a minimum distance of 16.6m from the source to produce echo.

### **Methods to Control Reverberation time:**

To control reverberation time the simplest way is to increase absorption in the hall.

The methods to control reverberation are:

1. *Provide few open windows in hall*-Open windows are good absorbers of sound and the reverberation time can be controlled by adjusting the number of open windows in the hall.
2. *Cover the floor with carpets*-The carpets are also good absorbers of sound which help in reducing the reverberation time in the hall.
3. *Curtains*-The use of heavy folded curtains on doors and windows allow to control the reverberation time.
4. *Cover the walls*-Covering the walls with absorbing materials like fibre or asbestos sheets etc. help in reducing reverberation time.

5. *Provide false ceiling*-False ceiling is made of sound absorbing materials which reduces the reverberation in a hall.
6. *Using upholstered cushioned seats in hall*- The seats in the empty hall would also absorb the sound if they are made of good absorbing cushioned material and turn up when no one is sitting on them.
7. *A good number of audience* increases the absorption of hall.

## 7.7 ULTRASONICS

The sound waves having frequency more than 20 kHz are called ultrasonics. Their characteristics are:

- i. They are high frequency and high energy waves.
- ii. If they are passed through a liquid it is shaken violently.
- iii. They work as a catalyst for chemical reactions.
- iv. They can be sent in the form of narrow beam to long distances without loss of energy.
- v. Travelling in one medium if they meet another, they return back in the same medium at 180 degree.
- vi. Just like ordinary sound waves, ultrasonic waves get reflected, refracted and absorbed.
- vii. They produce intense heating effect when passed through a substance.

**Production of Ultrasonic:** The natural producer of ultrasonics is 'Bat'. Another simple method to produce low frequency ultrasonics is 'Galton's whistle'. Two types of oscillators are used to produce ultrasonic sounds: Magnetostriction oscillator, Piezo electric oscillator.

**Applications of Ultrasonic:** Ultrasonic waves are used in various fields like; medical for ultrasound, navigation for various purposes, engineering for drilling, cleaning, flaw detection etc. Some important applications of ultrasonic are described below:

- 1) **Drilling:** Ultrasonic is high frequency and high energy wave, so they can be used in applications involving high amount of energy. They can be used to make a drill even in the hardest material of the world i.e. Diamond. For this a tool bit is attached at the lower end of magnetostriction oscillator. The sheet to be drilled is kept below the tool bit. It is driven by a magnetostriction oscillator that creates the vibrations. When the oscillator is switched on the tool bit moves up and down that produces enough strain to make a drill in the sheet. This setup of drilling is shown in Fig. 7.7.

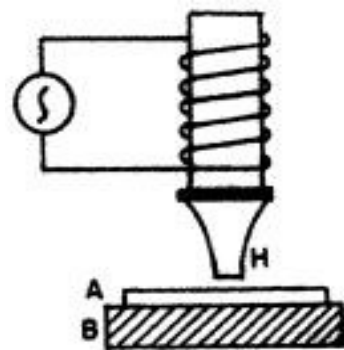

Fig. 7.7 Ultrasonic drilling

- 2) **Ultrasonic welding (cold welding):** The setup is shown in Fig. 7.8. Cold welding means welding without involvement of heat which is possible only with ultrasonics. A hammer is attached at the lower end of magnetostriction oscillator. The sheets to be welded are kept below the hammer. When the oscillator is switched on the hammer strikes the sheets frequently. In case of resonance the molecules of both sheets enter into each other due to high amplitude

and welding is performed without involvement of heat. The interface of the two parts is specially designed to concentrate the energy for maximum weld strength.

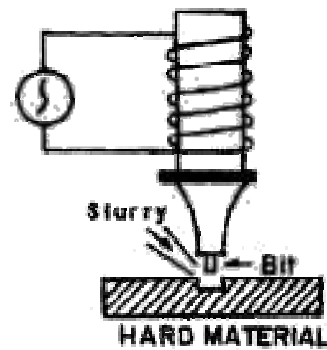

Fig.7.8 Coldwelding

- 3) **SONAR:** SONAR is a technique which stands for Sound Navigation and Ranging. It uses ultrasonic for the detection and identification of underwater objects. A powerful beam of ultrasonic is sent in the suspected direction in water. By noting the time interval between the emission and receipt of beam after reflection, the distance of the object can be easily calculated. Measuring the time interval ( $t$ ) between the transmitted pulses and the received pulse, the distance between the transmitter and the remote object is determined using the formula

$$d = V \times \frac{t}{2}$$

where  $V$  is the velocity of sound in sea water. The same principle is used to find the depth of the sea as shown in Fig. 7.9.

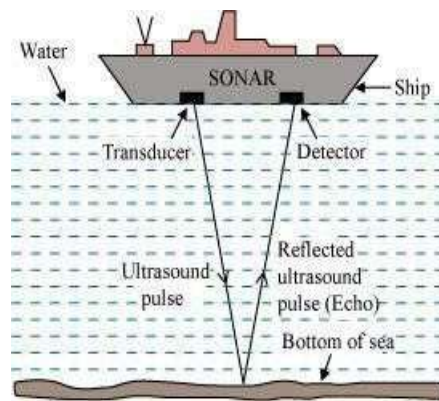

Fig.7.9 Sound navigation and ranging

**Numerical 3.** An ultrasonic scanner travelling with a speed of 1.5 km/s in a tissue operating under a frequency of 4.1 MHz. What is the wavelength of sound in the tissue?

**Solution:**

Given, Velocity ( $V$ ) = 1.5 km/s =

$$1.5 \times 1000 = 1500 \text{ m/s} \quad \text{Frequency } (\nu) = 4.1 \text{ MHz} = 4.1 \times 10^6 \text{ Hz}$$

Using the relation;  $V = \nu \lambda$  we can get

$$\text{Wavelength, } \lambda = \frac{V}{\nu} = \frac{1500}{4.1 \times 10^6} = 3.65 \times 10^{-4} \text{ m} = 36.5 \text{ mm}$$

**Numerical 4.** A man hears his sound again after reflection from a cliff after 1 second. If the velocity of sound is 330 m/s, find the distance of cliff from the man.

**Solution:** Given

Velocity of sound,  $V = 330 \text{ m/s}$

Time after which sound is heard,  $t = 1.0 \text{ s}$

Let  $d$  be the distance of cliff from man.

Total distance travelled by sound going and coming back from cliff =  $2d$

Thus,  $2d = v \times t = 330 \times 1 = 330 \text{ m}$

$$d = \frac{330}{2} = 165 \text{ m}$$

\*\*\*\*\*

# UNIT -2

## (OPTICS)

### Introduction

Optics is the branch of physics which deals with the study of behavior and properties of light. Light is an electromagnetic wave having transverse nature. Although light has dual nature; particle as well as wave, classical approach considers only wave nature. The wave nature is further simplified in geometric optics, where light is treated as a ray which travels in straight line. Ray optics model includes wave effects like diffraction, interference etc. Quantum optics deals with application of light considered as particles (called photons) to the optical systems. The phenomena of photoelectric effect, X-rays and lasers are explained in the quantum optics (particle nature of light).

### Ray Optics (Geometric Optics)

Geometrical optics describes the propagation of light in terms of rays. The assumptions of geometrical optics are:

- Light travels in straight-line paths.
- It bends, or splits into part, at the interface between two different media.
- It follows curved paths in a medium where refractive index changes.
- It may be reflected, absorbed or transmitted.

### 8.1 REFLECTION AND REFRACTION OF LIGHT

#### Reflection of Light

*Reflection is the bouncing back of light at an interface between two different media.*

Glassy surfaces such as mirrors exhibit specular reflection. This allows for production of reflected images that can be associated with real or virtual location in space. Figure 8.1 depicts the phenomenon of reflection from a glass-air interface. PO is the light ray incident on a glass mirror at an angle  $\theta_i$  (angle of incident) and OQ is the light ray reflected from the surface at an angle  $\theta_r$  (angle of reflection).

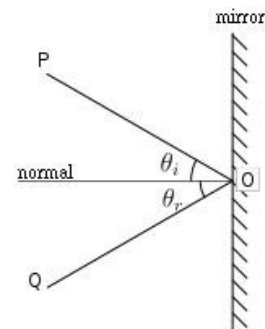

Fig.8.1 Reflection of light

#### Laws of reflection:

- 1) The incident and reflected ray and the normal, all lie in the same plane, and

2) The angle between the incident ray and the normal is the same as that between the reflected ray and the normal i.e.  $\theta_i = \theta_r$

## Refraction of light

When a light ray passes from one transparent medium to another, it gets deviated from its original path while crossing the interface of two media. *The phenomenon of bending of light rays from their original path while passing from one medium to another is called refraction.*

- When light travels from a rarer medium to a denser medium, it bends towards the normal.
- When light travels from a denser medium to a rarer medium, it bends away from the normal.

It happens when light travels through a medium that has a changing index of refraction. Refraction occurs due to a change in the speed of light as it enters a different medium. Figure 8.2 describes the occurrence of refraction at an interface.

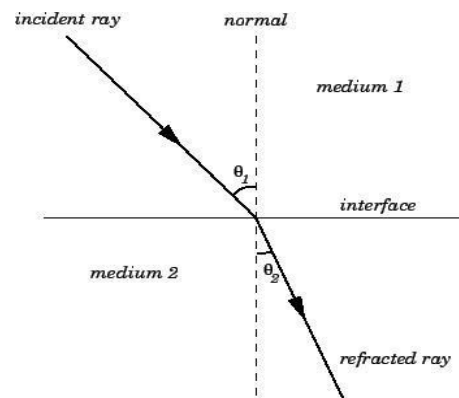

### Laws of refraction:

- 1) The incident ray, the refracted ray, and the normal all lie in the same plane.
- 2) The ratio of the sine of the angle of incidence ( $\theta_1$ ) to the sine of the angle of refraction ( $\theta_2$ ) is a constant for that pair of media. This is equal to the **refractive index** of that media. This is also known as **Snell's law**.

$${}^1\mu_2 = \frac{\sin \theta_1}{\sin \theta_2} = \frac{\sin i}{\sin r}$$

Where 'i' is the angle of incidence and 'r' is the angle of refraction and  ${}^1\mu_2$  is the refractive index of medium 2 w.r.t. medium 1. If medium 1 is vacuum then,

$$\mu = \frac{\sin \theta}{\sin \theta_2}$$

When light travels from air (vacuum) to a medium then the refractive index of the medium can be written as

$$\mu = \frac{c}{v}$$

where c is the velocity of light in air (vacuum) and v is the velocity of light in the medium. For example, the refractive index of water is 1.333, meaning that light travels 1.333 times slower in the water than in vacuum. Thus, the refractive index of a material is a dimensionless number that describes how light propagates through that medium.

The Snell's law is used to find the deflection of light rays when they pass through different media. It is used to produce dispersion spectra through a prism since light rays having different frequencies have slightly different refractive index in most materials.

The refractive index of some material varies with position and time. In such medium, light travels in curved path rather than straight lines. This is responsible for mirage effect observed on hot day due to different refractive index of air that causes light to bend, creating specular reflections in distance (as if water on the surface of a pool). The material having varying refractive index is useful in modern photocopy and scanning technologies.

### **Lens and Lens Formula**

Lens is an optical device based on phenomenon of refraction. A lens is a transparent medium bounded by two refracting surfaces. It can produce two types of rays- converging and diverging rays. Convex lens is converging while concave lens is diverging.

#### **Terms related in study of lenses:**

1. **Centre of curvature:** The center of curvature of a lens is the center of sphere which forms a part of the spherical surface of the lens.
2. **Radius of curvature:** The radius of the sphere of the spherical surface of lens is called radius of curvature. It is the distance of the vertex of the lens from the center of curvature.
3. **Principal axis:** The principal axis of a lens is an imaginary line that is perpendicular to the vertical axis of the lens. Principal focus of the lens lies on this axis. All rays parallel to the principal axis that are incident on the lens, would either converge (if lens is converging) to, or diverge (if the lens is diverging) from, the principal focus.
4. **Optical centre:** Optical centre is the center of the lens lying on the principal axis. If a light ray passes through optical centre, it goes undeviated.
5. **Principal focus:** When the parallel rays are incident on a lens, they either converge at a point or appear to diverge from a point on the principal axis, that point is called principal focus.
6. **Focal length (f):** The distance of principal focus from the optical centre is called focal length. In other words, focal length is equal to the image distance when the object is at infinity.
7. **Image:** If two or more rays passing from a point gets refracted through a lens and converges or appears to diverge to a point then that point is called the image of first point. The image can be real or virtual. In real image, rays actually meet at the second point, while in virtual image; the rays appear to diverge from the second point.

### **Lens formula**

The focal length (f) of a convex lens is related to object distance (u) and image distance (v) as

$$\frac{1}{f} = \frac{1}{v} - \frac{1}{u} \quad \Rightarrow \text{This is called lens formula.}$$

The linear magnification of a lens is given by;  $m = \frac{v}{u}$  and holds for both convex and concave lenses and for real as well as virtual images.

### Power of lens

Power of a lens is defined as the reciprocal of the focal length measured in metres. The unit of power of lens is  $m^{-1}$  which is called **diopetre** indicated by symbol 'D'. In other words, one diopetre is the power of a lens of one metre focal length.

$$P = \frac{1}{f} \quad (\text{f is taken in meters})$$

The power of a convex lens is positive and that of a concave lens is negative. If two lenses are combined (placed in contact), the focal length of the combination is given by

$$\frac{1}{F} = \frac{1}{f_1} + \frac{1}{f_2}$$

Thus the power of combination becomes the sum of power of individual lenses. i.e.

$$P = P_1 + P_2$$

## 8.2 TOTAL INTERNAL REFLECTION (TIR)

When light is reflected into a denser medium from an interface of the denser and a rarer medium, and there is no refracted light, the phenomenon is known as total internal reflection.

There are two essential conditions for TIR:

1. The light should travel from a denser medium to a rarer medium.
2. The angle of incidence in the denser medium should be greater than the critical angle.

The largest possible angle of incidence at the interface which results in a refracted ray is called the **critical angle**. At the critical angle of incidence, the refracted ray travels along the boundary between the two media i.e. the angle of refraction becomes  $90^\circ$ . For an angle of incidence greater than critical angle light is totally reflected as shown in Fig. 8.3.

The critical angle for a material depends upon the refractive index. Higher the refractive index, the lower the critical angle. It can be calculated using the following formula:

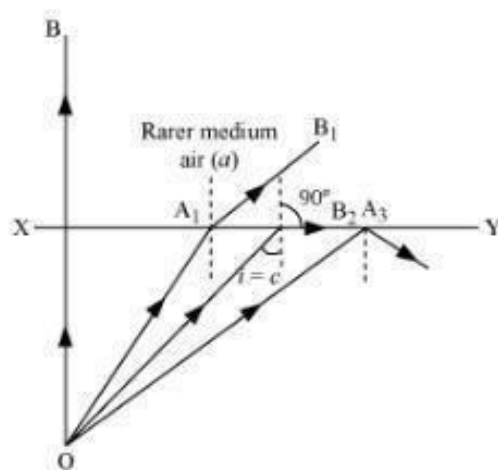

Fig. 8.3 Total internal reflection

$$\sin \theta_c = \frac{1}{\mu}$$

where  $\theta_c$  is the critical angle and  $\mu$  is the refractive index.

### Applications of TIR

1. TIR is the basic principle of optical fibers which are used as a transmission medium in sending telecommunication signals and images in endoscopes.
2. Automotive rain sensors work on the principle of TIR, which control automatic windshield wipers.
3. Prisms in binoculars also form erect images based on total internal reflection.
4. Some multi-touch screens also use TIR to pick up multiple targets.
5. Optical fingerprinting devices used to record fingerprints without the use of ink are also based on TIR.
6. The bright shining of diamonds is also a result of total internal reflection.

## 8.3 OPTICAL INSTRUMENTS

An optical instrument is a device which is used to view the objects. The eye is basic and essential optical system. In addition to it, other instruments are devised to increase the range a human's viewing ability. The optical instruments are an aid to the eye. They consist of an arrangement of lenses, prisms or mirrors which enables to see better than what we can see with the naked eye. These can be of two types:

1. When the real image is formed on a screen as in case of photographic camera, overhead projector etc.
2. When a virtual image is formed and can be seen directly with the eye as in telescopes, microscopes, binoculars etc.

In the present scope, we will study about two optical instruments; microscopes and telescopes.

**a) Microscope:** *A microscope is an optical instrument which enables us to see magnified image of objects that are too small to be seen by the naked eye. A microscopic object is invisible to the eye unless aided by a microscope. Fig.8.4 shows the view of a microscope.*

There are two types of microscope:

1. **Simple microscope.** It is also known as magnifying glass. It is made of only one convex lens and the object is so adjusted before the focal point that the image is formed at least distance of distinct vision.
2. **Compound microscope.** The magnification produced by a simple microscope is small and is only governed



**Fig.8.4** A microscope

by the focal length of lens. To produce a large magnification, a compound microscope is used in which magnification is obtained in two stages by the use of two convex lenses.

b) **Telescope:** A telescope is an optical instrument which is used to see distant objects clearly. There are three types of telescopes:

1. **Astronomical** (to see astronomical objects): It is used to see heavenly objects like stars and planets. The image formed in an astronomical telescope is inverted.
2. **Terrestrial** (To see objects on earth): Astronomical telescope forms an inverted image which is not suitable to see the terrestrial objects like buildings, trees etc. For seeing the distant objects lying on earth, the final image should be erect. A terrestrial telescope (Fig. 8.5) forms an erect image and makes use of three convex lenses.



**Fig.8.5**A Telescope

3. **Galilean** (modification of terrestrial telescope): It is a modified version of terrestrial telescope which also forms erect image but with the use of only two lenses.

## 8.4 USES OF MICROSCOPE AND TELESCOPE

### a) Uses of Microscope

1. Biological scientists use microscope to see microorganisms and their behavior.
2. Doctors use microscope to see and examine blood cells and bacteria.
3. Forensic science experts use microscope to analyze the evidences of crimes.
4. Jewelers and watchmakers use it to see the details of parts they are working with.
5. Environmentalist uses it to test the soil and water samples for presence of pollutants.
6. Geologist uses it to test the composition of different types of rocks.
7. These are used in various experiments in schools and colleges.

### b) Uses of Telescope

1. Astronomical objects are seen by using telescope by astronomers.
2. They find use in terrestrial applications also. They are used in laboratories to perform different experiments and finding values of different quantities.
3. Spectrometry uses telescope to find wavelength of light and spectral lines etc.
4. It is used in spy glasses and long focus camera lenses.

### Solved Numericals

**Numerical 1.** A lens is having power of +4D. What is its focal length?

**Solution:** Given, Power (P) = +4D

We know that  $P = \frac{1}{f}$

Therefore,  $4 = \frac{1}{f} \Rightarrow f = \frac{1}{4} \text{ m} = 0.25 \text{ m} = 25 \text{ cm}$

Thus, focal length of lens is 25 cm

**Numerical 2.** An object is kept at a distance of 30 cm from a convex lens of focal length 0.2 m. Find the position of the image formed.

**Solution:** Given, distance of object,  $u = -30 \text{ cm} = -0.3 \text{ m}$ , and  $f = 0.2 \text{ m}$

The lens formula is  $\frac{1}{f} = \frac{1}{v} + \frac{1}{u}$

or

$$\frac{1}{0.2} = \frac{1}{v} + \frac{1}{-0.3} \Rightarrow \frac{1}{v} = \frac{1}{0.2} - \frac{1}{0.3} = 5 - 3.33 = 1.67 \text{ m}^{-1}$$

$$v = \frac{1}{1.67} = 0.598 \text{ m} = 60 \text{ cm}$$

**Numerical 3.** A light wave has a wavelength of 600 nm in vacuum. What is the wavelength of the light as it travels through water (index of refraction = 1.33)?

**Solution:**

Given, wavelength ( $\lambda$ ) = 600 nm =  $600 \times 10^{-9} \text{ m}$  (1 nm =  $10^{-9} \text{ m}$ ).

The wavelength of light that travels through a medium of refractive index  $n$  changes by the expression

$$\lambda_n = \frac{\lambda}{n} = \frac{600 \times 10^{-9}}{1.33} = 451 \times 10^{-9} \text{ m} = 451 \text{ nm}$$

\*\*\*\*\*

## UNIT-3

# ELECTROSTATICS

The branch of physics which deals with the study of charges at rest is called electrostatics.

### 9.1. ELECTRIC CHARGE

**Electric Charge:** it is the physical property of matter that causes it to experience force when placed in an electromagnetic field. There are two types of charges.

- (1) **Positive charge:** e.g. Proton, Alpha particle
- (2) **Negative charge:** e.g. Electron, etc.

Charge on electron is smallest unit of charge.

SI unit of charge is coulomb (C).

$$\text{Charge on Electron} = -1.6 \times 10^{-19} \text{ C}$$

$$\text{Charge on Proton} = +1.6 \times 10^{-19} \text{ C}$$

Like charges repel each other and unlike charges attract each other. i.e.

|     |     |         |
|-----|-----|---------|
| +ve | +ve | Repel   |
| -ve | -ve | Repel   |
| +ve | -ve | Attract |
| -ve | +ve | Attract |

### Conservation of Charge

*Charge conservation* is the principle that total electric charge in an isolated system never changes. It always remains constant. This also means that no net charge can be created or destroyed. When an atom is ionized, equal amounts of positive and negative charges are produced. Hence the algebraic sum of charges before and after remains the same.

### Quantization of Charges

*Charge quantization* is the principle that the charge of any object is an integer multiple of the elementary charge ( $e$ ). Thus, an object's charge can be exactly  $0e$ , or exactly  $1e$ ,  $-1e$ ,  $2e$ , etc.,

### 9.2. COULOMB LAW OF ELECTROSTATICS

It states that force of interaction between two point charges is

- (i) Directly proportional to magnitude of charges and

(ii) Inversely proportional to the square of the distance between them.

Let  $F$  is force between two charges  $q_1$  and  $q_2$ . Then

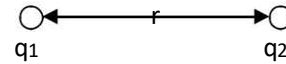

$$F \propto q_1 q_2$$

$$F \propto \frac{1}{r^2}$$

$$\Rightarrow F \propto \frac{q_1 q_2}{r^2} \quad \dots\dots\dots(1)$$

$$F = K \frac{q_1 q_2}{r^2} \quad \dots\dots\dots(2)$$

where  $K$  is constant of proportionality and its value is given as

$$K = \frac{1}{4\pi\epsilon_0} = 9 \times 10^9 \text{ Nm}^2/\text{C}^2 \text{ (in SI unit system)}$$

Now from equation (2)

$$F = \frac{q_1 q_2}{4\pi\epsilon_0 r^2} \quad \dots\dots\dots(3)$$

Here  $\epsilon_0$  is electrical permittivity of vacuum. Its value is  $8.854 \times 10^{-12} \text{ N}^{-1} \text{ m}^{-2} \text{ C}^2$ .

Let  $q_1 = q_2 = q$

$r = 1 \text{ m}$

then from equation (3)  $F = 9 \times 10^9 \text{ N}$

Thus one coulomb is that much charge which produces a force of  $9 \times 10^9 \text{ N}$  at a unit charge placed at a distance of 1 m.

Smaller unit of charge;

milliCoulomb (mC) =  $10^{-3} \text{ C}$ .

microCoulomb ( $\mu\text{C}$ ) =  $10^{-6} \text{ C}$ .

### 9.3. ELECTRIC FIELD

It is the area around the charge in which force of attraction or repulsion can be experienced by another charge.

Electric field intensity at point is defined as the force acting on a unit positive charge at that point.

$$\vec{E} = \frac{\vec{F}}{q_0}$$

• A unit positive charge is also called as test charge

The value of  $q_0$  should be very small. Its SI unit is N/C (Newton per Coulomb)

#### Electric Lines of Force:

An electric line of force is an imaginary continuous line or curved drawn in an electric field such that tangent to it at any point gives the direction of electric force at that point (Fig. 9.1).

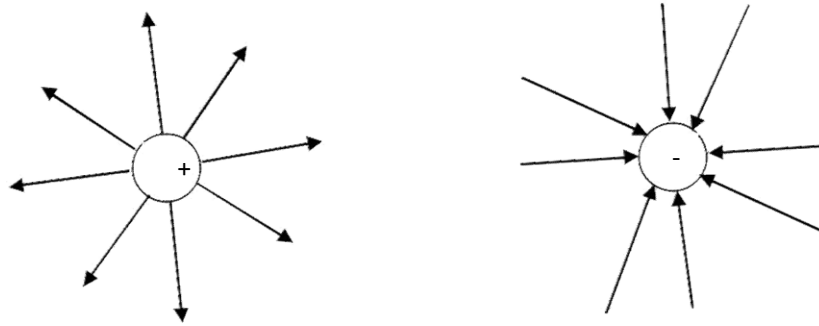

Figure 9.1

**Properties of electric lines of force**

- Lines of force originate from a positive charge and terminate to a negative charge.
  - The tangent to the line of force indicates the direction of the electric field and electric force.
  - Electric lines of force are always normal to the surface of charged body.
  - Electric lines of force contract longitudinally and expand laterally.
  - Two electric lines of force cannot intersect each other.
  - Two electric lines of force proceeding in the same direction repel each other.
  - Two electric lines of force proceeding in the opposite direction attract each other.
- There are no lines of force inside the conductor

**9.4. ELECTRIC FLUX**

It is the measure of distribution of electric field through a given surface. Electric flux is defined as total number of electric lines of force passing per unit area normal to the surface. It is denoted by  $\psi$  (psi).

Consider a small elementary area  $dS$  on a closed surface  $S$ . Electric field  $\vec{E}$  exits in the  $E$  space. If  $\theta$  is the angle between  $\vec{E}$  and area vectors as then

$$\psi = \int \vec{E} \cdot d\vec{S} \text{ is called electric flux.}$$

**GAUSS'S LAW**

It states that net electric flux of an electric field over a closed surface is equal to the net charge enclosed by the surface divided by  $\epsilon_0$ , i.e.

$$\psi = \int_S \vec{E} \cdot d\vec{S} = \frac{q}{\epsilon_0}$$

**Proof:** Consider a closed surface  $S$  having a charge  $q$  placed at a point  $O$  inside a closed surface as shown in Fig. 9.2. Take a point  $P$  on the surface and consider a small area  $dS$  around  $P$ .

$$OP = r$$

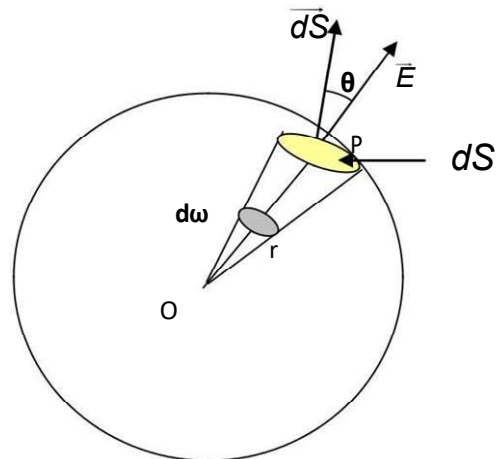

Figure 9.2

Then Electric field at  $P$  is

$$E = \frac{q}{4\pi\epsilon_0 r^2} \dots\dots\dots(1)$$

Now electric flux

$$\psi = \int_S \vec{E} \cdot d\vec{S} \cos\theta$$

Putting value of  $E$  we get

$$\psi = \int_S \frac{q}{4\pi\epsilon_0 r^2} dS \cos\theta$$

$$\psi = \frac{q}{4\pi\epsilon_0 r^2} \int_S dS \cos\theta$$

$$\psi = \frac{q}{4\pi\epsilon_0} \int_{0S} d\omega$$

$$\psi = \frac{q}{4\pi\epsilon_0} \cdot 4\pi$$

$$\psi = \frac{q}{\epsilon_0}$$

Hence,  $\psi = \int_S \vec{E} \cdot d\vec{S} \cos\theta = \frac{q}{\epsilon_0}$

$$\therefore \frac{dS \cos\theta = d\omega}{r^2}$$

$\therefore$  Total Solid angle =  $4\pi$

**Applications of Gauss's Law:**

**Electric field due to a point charge:**

Consider a point charge  $q$ . We want to find electric field at point  $P$  at a distance of  $r$  from it. Construct a spherical surface of radius  $r$ . This is called as Gaussian surface. Consider small area  $dS$  on the surface. Let  $\theta$  is angle between  $\vec{E}$  and Area vector as shown in Fig. 9.3.

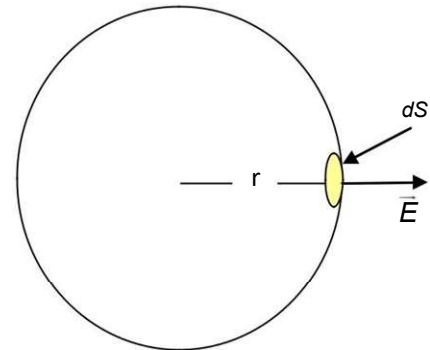

**Figure 9.3**

Now flux

$$\psi = \int_S \vec{E} \cdot d\vec{S} \cos\theta = \epsilon_0 \frac{q}{\epsilon_0}$$

( $\because \theta = 0$ )

$$\vec{E} \int_S dS = \epsilon_0 \frac{q}{\epsilon_0}$$

$$\Rightarrow E \cdot 4\pi r^2 = q \frac{1}{\epsilon_0}$$

( $\because$  Area of Sphere =  $4\pi r^2$ )

$$\Rightarrow \boxed{E = \frac{q}{4\pi\epsilon_0 r^2}}$$

Thus the electric intensity decreases with increase in distance.

## 9.5. CAPACITOR

It is an electronic component that stores electric charge.

### Capacitance

The ability of a system to store an electric charge.

A potential is proportional to charge

$$V \propto q$$

or

$$q \propto V$$

$$q = CV$$

$$C = \frac{q}{V}$$

Unit of capacitance: Farad (F), microfarad

### Grouping of Capacitors Series

#### Grouping:

A number of capacitors are said to be connected in series if -ve plate of one capacitor is connected to the +ve plate of other capacitor and so on. In this grouping, current is same on each capacitor.

Consider 3 capacitors of capacitances  $C_1, C_2, C_3$  in series. Let  $V$  is total applied voltage.  $V_1, V_2, V_3 \rightarrow$  voltage drops across  $C_1, C_2, C_3$  as shown in fig. 9.4.

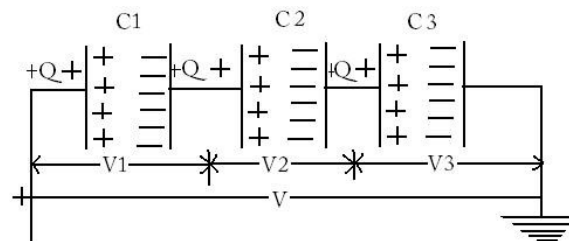

Figure 9.4

Then  $V = V_1 + V_2 + V_3$  -----(1)

Now  $C = \frac{q}{V} \Rightarrow V = \frac{q}{C}$

So,  $V = \frac{q}{C_1}, V = \frac{q}{C_2}, V = \frac{q}{C_3}$

Putting in Equation (1)

$$\frac{q}{C} = \frac{q}{C_1} + \frac{q}{C_2} + \frac{q}{C_3}$$

$$\frac{q}{C} = q \left( \frac{1}{C_1} + \frac{1}{C_2} + \frac{1}{C_3} \right)$$

$$\frac{1}{C} = \frac{1}{C_1} + \frac{1}{C_2} + \frac{1}{C_3}$$

So the total capacitance decreases in series grouping.

*The reciprocal of the equivalent capacitance of two capacitors connected in series is the sum of the reciprocals of the individual capacitances.*

### Parallel Grouping:

A number of capacitors are said to be connected in parallel if +ve plate of each capacitor is connected to the +ve terminal of battery and -ve plate of each capacitor is connected to the -ve terminal of battery.

In this grouping voltage across each capacitor is same.

Consider 3 capacitors of capacitances  $C_1, C_2, C_3$  connected in parallel let  $V$  is applied voltage.  $q_1, q_2, q_3 \rightarrow$  charges on capacitors  $C_1, C_2, C_3$  as shown in fig. 9.5

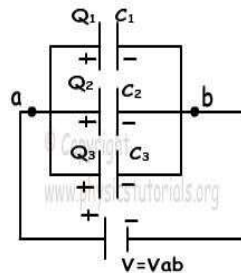

**Figure 9.5**

So

$$q = q_1 + q_2 + q_3 \text{ ----- (1)}$$

Now  $C = \frac{q}{V}$  or  $q = CV$

$$\therefore q_1 = C_1 V, \quad q_2 = C_2 V, \quad q_3 = C_3 V$$

Put in equation (1)

$$CV = C_1 V + C_2 V + C_3 V$$

$$CV = (C_1 + C_2 + C_3) V$$

$$C = C_1 + C_2 + C_3$$

So the total capacitance increases in parallel grouping.

*The equivalent capacitance of capacitors connected in parallel is the sum of the individual capacitance.*

### Solved Numericals

**Example 1.** Calculate the coulomb force between two protons separated by a distance of  $1.6 \times 10^{-15}$  m.

**Solution:** Given, 2 protons; Charge on Proton =  $1.6 \times 10^{-19}$  C  $q_1 =$

$$q_2 = 1.6 \times 10^{-19} \text{ C}$$

$$\text{Distance, } r = 1.6 \times 10^{-15} \text{ m}$$

$$\text{Also } \frac{1}{4\pi\epsilon_0} = 9 \times 10^9 \text{ Nm}^2/\text{C}^2$$

$$\frac{1}{r^2}$$

$$\text{Now } F = 4\pi\epsilon_0 r^2$$

$$\frac{9 \times 10^9 \times 1.6 \times 10^{-19} \times 1.6 \times 10^{-19}}{(1.6 \times 10^{-15})^2}$$

$$F =$$

$$(1.6 \times 10^{-15})^2$$

$$F = 90 \text{ N}$$

**Example 2.** Calculate the force between an alpha particle and a proton separated by a distance of  $5.12 \times 10^{-15}$  m.

**Solution:** Given,  $q_1 =$  Charge on alpha particle =  $2 \times 1.6 \times 10^{-19}$

$$q_2 = \text{Charge on proton} = 1.6 \times 10^{-19} \text{ C}$$

$$\text{distance, } r = 5.12 \times 10^{-15} \text{ m}$$

$$\frac{1}{4\pi\epsilon_0} = 9 \times 10^9 \text{ Nm}^2/\text{C}^2$$

Now

$$F = 4\pi\epsilon_0 \frac{q_1 q_2}{r^2}$$

$$F = \frac{9 \times 10^9 \times 3.2 \times 10^{-19} \times 1.6 \times 10^{-19}}{(5.12 \times 10^{-15})^2}$$

$$F = 17.58 \text{ N}$$

**Example 3.** Three capacitors of capacitances  $3 \mu\text{F}$ ,  $2 \mu\text{F}$  and  $4 \mu\text{F}$  are connected with each calculate total capacitance (a) In Series grouping (b) Parallel grouping.

**Solution:** Given,

$$C_1 = 3 \mu\text{F}, \quad C_2 = 2 \mu\text{F} \quad \text{and} \quad C_3 = 9 \mu\text{F}$$

In Series grouping

$$\frac{1}{C_{\text{tot}}} = \frac{1}{C_1} + \frac{1}{C_2} + \frac{1}{C_3}$$

$$\frac{1}{C_{\text{tot}}} = \frac{1}{3} + \frac{1}{2} + \frac{1}{9}$$

$$= \frac{17}{18} 18 \mu F$$

$$\therefore C_{\text{tot}} = 17 \frac{18}{18} = 1.06 \mu F$$

In Parallel grouping

$$C_{\text{tot}} = C_1 + C_2 + C_3$$

$$C_{\text{tot}} = 3 + 2 + 9 = 14 \mu F$$

**Example 4.** Three capacitors 1F, 2F, and 3F are joined in series first and then in parallel. Calculate the ratio of equivalent capacitance in two cases.

**Solution:** Given,

$$C_1 = 1F,$$

$$C_2 = 2F,$$

$$C_3 = 3F$$

In series grouping

$$\frac{1}{C_s} = \frac{1}{C_1} + \frac{1}{C_2} + \frac{1}{C_3}$$

$$\frac{1}{C_s} = \frac{1}{1} + \frac{1}{2} + \frac{1}{3}$$

$$\frac{1}{C_s} = \frac{11}{6}$$

$$\therefore C_s = \frac{6}{11} F$$

In Parallel grouping

$$C_p = C_1 + C_2 + C_3$$

$$C_p = 1 + 2 + 3 = 6F$$

$$\therefore \text{Ratio} = \frac{C_p}{C_s} = \frac{6}{\frac{6}{11}} = 11$$

or

$$\frac{C_p}{C_s} = 11$$

# UNIT-4: (CURRENT AND ELECTRICITY)

## 10.1 ELECTRIC CURRENT AND ITS UNITS

In a conductor, there are many free electrons. These electrons are in random motion but there is no net motion along the conductor. But if the two ends of a conductor are at different potentials, the charge will start flowing from one end of conductor to the other end. Therefore, the free electrons (charge) which were moving randomly will now move towards positive terminal of the battery and constitute a current. Hence a potential difference is always needed to make charge move from one end of the conductor to the other end of the conductor.

In a conductor the motion of the free electrons gives rise to the electric current as shown in Fig. 10.1.



Figure 10.1

Electric current passing through a conductor is *the rate of flow of charge passing through it*. If a charge of  $q$  units passes through any cross section of the conductor in  $t$  seconds. The current flowing through the wire ( $I$ ) is given by the formula

$$I = \frac{\text{Charge } q}{\text{time } t}$$

where  $I$  = the electric current

$q$  = charge

$t$  = time taken

**Unit:** Ampere (A)

In the relation

$$I = \frac{q}{t}$$

If the charge is measured in coulombs and time is measured in seconds then the unit of current will be ampere.

The direction of current is the direction of flow of positive charge i.e. opposite to the direction of flow of electron.

### One Ampere:

The current flowing through the conductor is said to be one ampere if one coulomb of charge flows through the conductor in one second.

### Potential Difference (V)

It is the difference in electric potential between two points in an electric circuit, the work that has to be done in transferring unit positive charge from one point to other.

**Unit:** Volts (V)

### One Volt:

It is defined as the consumption of one joule per electric charge of one coulomb.

$$1 = \frac{1}{1}$$

One volt is equal to current of 1 amp times resistance of 1 ohm.

### Direct Current

Direct current in an electric wire is that which flows in only one direction. It is the unidirectional flow of current. The electric current flowing through a semi-conductor diode is an example of direct current. Direct current (DC) is produced by sources such as batteries, fuel cells and solar cells and cannot travel over long distances since it has more loss of energy.

The frequency of DC is zero and it has a single polarity. In direct current the electron flow from negative end of the battery to the positive end of the battery.

### Symbol of DC voltage source

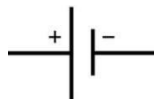

It can be shown by Fig. 10.2.



**Figure 10.2**

DC form is used in low voltage apparatus like charging batteries, cell phones, automotive apparatus, aircraft apparatus and other low voltage low current apparatus.

### AC(Alternatingcurrent)

As shown in Fig. 10.3,AC is current that reverses the direction periodically and also has a magnitude that varies continuously with time.

AC is used in our homes. Power stations generate ac because it is easy to low and raise the voltage with the help of transformers.In North America the frequency of AC is 60Hz and in India it is 50 Hz. The AC in our home is sinusoidal in nature.

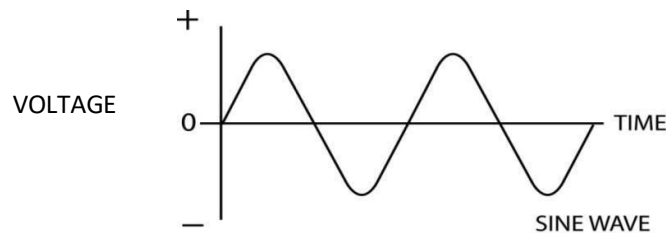

Figure10.3

The radio frequency current in antennas and transmission lines are the examples of AC.

### Symbol of AC



It is produced by an alternator and has more power and can be easily transferred from one place to another.

## 10.2 OHM'S LAW

According to Ohm's law "*The current flowing through a conductor is always directly proportional to the potential difference between the two ends if the physical condition (temperature, pressure etc.) of the conductor remains the same*".

If I is the current passing through a conductor and V is the potential difference between the ends of the conductor then

$$V \propto I$$

$$V = RI$$

$$\frac{V}{I} = R$$

Therefore,  $R = \frac{V \text{ Potential Difference}}{I \text{ Electric Current}}$

where R is a constant and is called electric resistance.

The value of R depends upon nature, dimension and temperature of the conductor.

$$V=IR$$

Therefore  $I = \frac{V}{R}$   
 If a graph is drawn between current (I) and the potential difference (V) it will be a straight line for a conductor (Fig. 10.4).

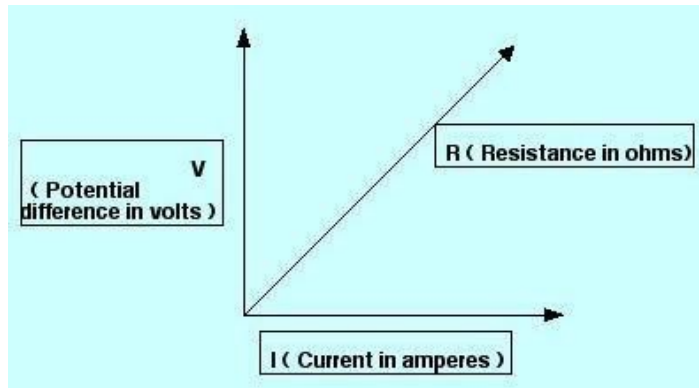

**Figure 10.4**

### 10.3 RESISTANCE (R)

The opposition to the flow of electric current in an electric circuit is called resistance. Therefore, it is the measure of the difficulty to pass an electric current through the circuit.

$$R = \frac{V}{I}$$

If V is measured in volts and I is measured in amperes then the resistance R is measured in ohms.

**Symbol:**



**Unit: Ohms ( $\Omega$ )**

One Ohm:

$$1 \text{ ohm} = \frac{1 \text{ V}}{1 \text{ A}}$$

Therefore, one ohm is the resistance of a conductor in which a current of one ampere flows through it when the potential difference of one volt is maintained between its two ends.

#### Specific Resistance (Definition and Units)

The resistance of a conductor depends on the following factors;

(i) The resistance of a given conductor is directly proportional to its length, i.e.

$$R \propto l \dots \dots \dots (1)$$

ii) The resistance of a given conductor is inversely proportional to its area of cross-section.

$$R \propto \frac{1}{A} \dots \dots \dots (2)$$

By combining equation (1) and (2), we get

$$R \propto \frac{\rho l}{A}$$
$$R = \rho \frac{l}{A}$$

or

where  $\rho$  (rho) is a constant and known as specific resistance or resistivity of the material. The resistivity of a material does not depend on its length or thickness. It depends on the nature of the material.

If  $l = 1\text{m}$  and  $A = 1\text{m}^2$  then from above equation

$$\rho = R$$

Thus resistivity of the material is the resistance of a conductor having unit length and unit area of cross-section.

Units: Ohm-m ( $\Omega\text{m}$ )

### Conductivity

*It is the degree to which an object conducts electricity. This is the reciprocal of the resistivity,*

$$\sigma = \frac{1}{\rho}$$

Where,  $\sigma$  is the conductivity and  $\rho$  is the resistivity of the conductor.

Unit: Siemens per meter or mho per meter

### Conductance (G)

It is the reciprocal of the resistance and it is a measure of ease with which the current flows through a substance.

$$G = \frac{1}{R}$$

where  $G = \text{Conductance}$   
 $R = \text{Resistance}$

Unit: mho

## 10.4 COMBINATION OF RESISTANCES

### 1. Series combination

The resistance is said to be connected in series if the same current passes through all the resistances and the potential difference is different across each resistance.

Let three resistances  $R_1, R_2, R_3$  be connected in series as shown in the Fig. 10.5

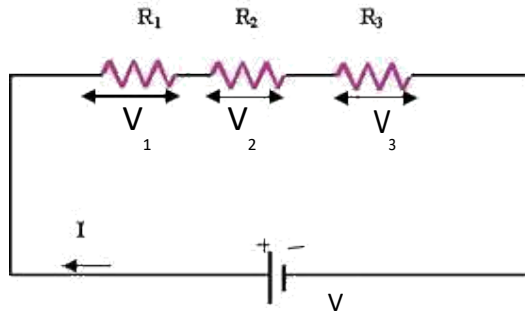

Figure 10.5

Let

$V$  = Voltage applied across the series combination  
 $I$  = Current passing through the circuit  
 Clearly current  $I$  is same throughout the circuit

Let  $V_1, V_2, V_3$  be the potential difference across  $R_1, R_2, R_3$  respectively. Then, according to Ohm's law

$$V = IR$$

where  $R$  is the total resistance in series

Now

$$V = V_1 + V_2 + V_3 \text{-----} \quad (1)$$

Then by Ohm's law

$$V_1 = I R_1$$

$$V_2 = I R_2$$

$$V_3 = I R_3$$

Putting the values of  $V_1, V_2$  and  $V_3$  in equation (1) we

$$\text{get } IR = IR_1 + IR_2 + IR_3$$

$$= I (R_1 + R_2 + R_3)$$

$$R = (R_1 + R_2 + R_3)$$

Thus the combined resistances when they are connected in series is the sum total of the individual resistances.

## 2. Parallel Combination

The resistances are said to be connected in parallel if the potential difference across each resistance is the same but the current passing through each resistance is different.

Let there be three resistances  $R_1, R_2, R_3$  connected in parallel as shown in Fig. 10.6. One end of each resistance is connected to point A and the other end of each resistance is connected to the point B.

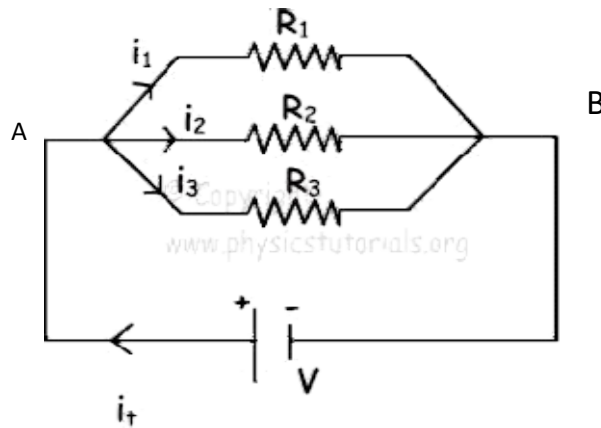

Figure 10.6

Let

$V$  = Potential Difference applied across A and B

Clearly, potential difference  $V$  is same across each resistance. Let

$I$  = total current flowing in the circuit.

$R$  = total resistance of the circuit

Let  $I_1, I_2, I_3$  be the current passing through the resistances  $R_1, R_2, R_3$  respectively.

From Ohm's law applied to the whole circuit

$$I = \frac{V}{R}$$

$$I_1 = \frac{V}{R_1}$$

$$I_2 = \frac{V}{R_2}$$

$$I_3 = \frac{V}{R_3}$$

Now we have,

$$I = I_1 + I_2 + I_3 \text{ ----- (2)}$$

Putting the values of  $I, I_1, I_2, I_3$  in the equation (2)

$$\frac{V}{R} = \frac{V}{R_1} + \frac{V}{R_2} + \frac{V}{R_3}$$

$$V = V \left( \frac{1}{R_1} + \frac{1}{R_2} + \frac{1}{R_3} \right)$$

Or

$$\frac{1}{R} = \frac{1}{R_1} + \frac{1}{R_2} + \frac{1}{R_3}$$

Thus we can say that if the resistances are connected in parallel, then the reciprocal of the equivalent resistance is equal to the sum of reciprocals of individual resistances in the circuit.

### 10.5 HEATING EFFECT OF ELECTRIC CURRENT

When an electric current is passed through a conductor, the conductor becomes hot after some time and produces heat. This happens due to the conversion of some electric

energy passing through the conductor into heat energy. This effect of electric current is called heating effect of current.

The heating effect of current was studied experimentally by Joule in 1841. After doing these experiments, Joule came to the conclusion that the heat produced in a conductor is directly proportional to the product of square of current ( $I^2$ ), resistance of the conductor (R) and the time (t) for which current is passed. Thus,

$$H = I^2 R t$$

### Derivation of Formula

To calculate the heat produced in a conductor, consider current I is flowing through a conductor of resistance R for time t. Also consider that the potential difference applied across its two ends is V.

Now, total amount of work done in moving a charge q from point A to point B is given by:

$$W = q \times V \text{ ----- (1)}$$

Now, we know that charge = current  $\times$  time

$$\text{or } q = I \times t$$

$$\text{and } V = I \times R \text{ (Ohm's law)}$$

Putting the values of q and V in equation (1), we get

$$W = (I \times t) \times (I \times R)$$

$$\text{or } W = I^2 R t$$

Now, assuming that all the work done is converted into heat energy we can replace symbol of 'work done' with that of 'heat produced'. So,

$$H = I^2 R t$$

### Applications of Heating Effect of Current

The heating effect of current is used in various electrical heating appliances such as electric bulb, electric iron, room heaters, geysers, electric fuse etc.

## 10.6 ELECTRIC POWER

Electric power is the rate, per unit time, at which electric energy is transferred by an electric circuit.

$$\text{Let } P = \text{Electric power}$$

$$= W/t$$

$$P = VI$$

Where, V is the applied voltage and I is the current flowing through the circuit. SI unit of power is Volt (V).

$$\text{Now } P = VI$$

$$\text{If, } V = 1 \text{ Volt (1V) and } I = 1 \text{ Ampere (1A), then,}$$

$$P = 1 \text{ Watt}$$

Thus, power is said to be 1 watt, if a potential difference of 1 volt causes 1 ampere of current to flow through the circuit.

Bigger unit of electric power are Kilo Watt (KW) and Mega Watt (MW)

### 10.7 KIRCHHOFF'S LAWS

These two rules are commonly known as: Kirchhoff's circuit laws with one of Kirchhoff's laws dealing with the current flowing around a closed circuit, Kirchhoff's Current law (KCL) while the other law deals with the voltage sources present in a closed circuit, Kirchhoff's Voltage law, (KVL).

#### (i) Kirchhoff's First Law (Kirchhoff's Current Law) KCL

The law states that "The algebraic sum of all the currents meeting at any junction point in an electric circuit is zero"

$$\Sigma I = 0$$

Let us suppose the currents  $I_1, I_2, I_3$  entering the junction are all positives in value and the two currents  $I_4, I_5$  are leaving the junction are negative in values (Fig. 10.7), then according to KCL

$$I_1 + I_2 + I_3 - I_4 - I_5 = 0 \quad I_1 + I_2 + I_3 = I_4 + I_5$$

Sum of incoming currents = sum of outgoing currents

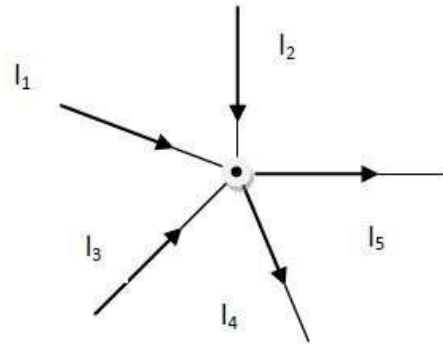

Figure 10.7

#### (ii) Kirchhoff's Second Law (Kirchhoff's Voltage Law) KVL

The law states that "In any closed loop of a circuit, the algebraic sum of products of the resistances and currents plus the algebraic sum of all the e.m.f. in that circuit is zero".

In any closed circuit;  $\Sigma E + \Sigma IR = 0$

Here we use two sign conventions (Fig. 10.8).

1. If we go from negative terminal of the battery to the positive terminal then there is rise in potential and it is considered positive. And if we go from positive terminal to negative terminal, there is fall of potential and it is considered as negative.

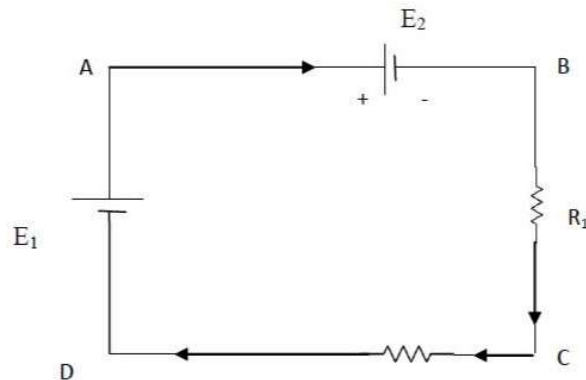

Figure 10.8

2. If we go with the current, voltage drop is negative and if we go against the current, the voltage drop is positive.

In the closed loop ABCD using KVL we get

$$- E_2 - IR_1 - IR_2 + E_1 = 0$$

## Solved Numericals

**Example 1.** An emf source of 6V is connected to a resistive lamp and a current of 2 amperes flows. What is the resistance of lamp?

**Solution.** Given,  $V=6V$  and  $I=2A$

$$\begin{aligned} \text{From Ohm's law, we know, } V &= IR & \text{or } R &= V/I \\ R &= 6/2 = 3\Omega \end{aligned}$$

**Example 2.** An electric fan has a resistance of 100 ohms. It is plugged into a potential difference of 220 V. How much current passes through the fan?

**Solution.** Given,  $R = 100 \text{ ohms}$  and  $V = 220 \text{ V}$

$$\text{We know, } I = V/R = 220/100$$

$$\text{Therefore } I = 2.2A$$

**Example 3.** Calculate the total resistance if three resistances of 1 ohm, 2 ohm and 3 ohm are connected in series.

**Solution.** Given resistances,  $R_1=1\text{ohm}$ ,

$$R_2=2\text{ohm}$$

$$R_3=3\text{ohm}$$

We know that in series combination;  $R=R_1 + R_2 + R_3$

$$\text{Therefore } R=1+2+3=6\text{ohm}$$

**Example 4.** Calculate the total resistance if three resistances of 4 ohm, 1 ohm and 6 ohm are connected in parallel.

**Solution.** Given,  $R_1=4\text{ohm}$

$$R_2=1\text{ohm}$$

$$R_3=6\text{ohm}$$

From formula we know in parallel combination

$$\frac{1}{R} = \frac{1}{R_1} + \frac{1}{R_2} + \frac{1}{R_3}$$

$$\text{Hence } \frac{1}{R} = \frac{1}{4} + \frac{1}{1} + \frac{1}{6} = \frac{3+12+2}{12} = \frac{17}{12}$$

$$\text{Therefore, Total resistance, } R = \frac{12}{17} \text{ohm}$$

# UNIT -5: ( ELECTROMAGNETISM)

## 11.1 ELECTROMAGNETISM

Electromagnetism or magnetism in general is the study of production of magnetic field when current is passed through a conductor. Various terms associated with magnetism are;

### **Magnetization(I)**

It represents the extent to which a material is magnetized when placed in a magnetic field. It is given by magnetic moment per unit volume of material.

$$I = \frac{M}{V}$$

where,  $M$  is magnetic moment and  $V$  is volume of the material.

Unit: Ampere/meter

### **Magnetic Intensity(H):**

It is the capability of magnetic field to magnetize a magnetic material.

### **Magnetic Permeability( $\mu$ ):**

It is a property of material and defined as the degree to which magnetic lines of force can penetrate the medium.

### **Magnetic susceptibility( $\chi$ ):**

It is a property which determines how easily a specimen can be magnetised. It is given by ratio of magnetization and magnetic Intensity.

$$\chi = \frac{I}{H}$$

### **Types of Magnetic Materials:**

On the basis of behaviour of magnetic material in magnetic field, the materials are divided into three categories:

#### 1. **Diamagnetic materials:**

The materials when placed in magnetic field, acquire magnetism opposite to the direction of magnetic field. The magnetic dipoles in these substances tend to align opposite to the applied field and tend to repel the external field around it.

- Diamagnetic substances have tendency to move from strong to the weaker magnetic field.
- When rod of diamagnetic material is placed in magnetic field, it aligns perpendicular to the magnetic field.
- Permeability of diamagnetic material is  $< 1$ .

Examples; gold, water, mercury, graphite, lead etc

## 2. Paramagnetic materials:

Paramagnetic substances are those which get weakly magnetized when placed in an external magnetic field. These materials show weak attraction in magnetic field. The magnetic dipoles in the magnetic materials tend to align along the applied magnetic field. Such materials show weak feeble magnetization and the magnetization disappears as soon as the external field is removed.

- Permeability of paramagnetic material is  $> 1$ .
- The magnetization ( $I$ ) of such materials dependent on the external magnetic field ( $B$ ) and temperature ( $T$ ) as:

$$I = C \frac{B}{T}$$

Where  $C$  is the Curie constant.

Examples: sodium, platinum, liquid oxygen, salts of iron and nickel.

## Ferromagnetic materials:

Ferromagnetic substances are those which get strongly magnetized when placed in an external magnetic field. They exhibit the strongest attraction in magnetic field. Magnetic dipoles in these materials are arranged into domains.

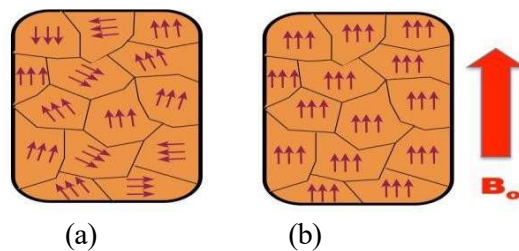

**Figure 11.1**

These domains are usually randomly oriented as shown in Fig. 11.1 (a) and net magnetism is zero in the absence of magnetic field. When an external field is applied, the domains reorient themselves to reinforce the external field as shown in Fig. 11.1 (b) and produce a strong internal magnetic field that is along the external field.

These materials show magnetism on removal of magnetic field.

Examples are iron, cobalt, nickel, neodymium and their alloys. These are usually highly ferromagnetic and are used to make permanent magnets.

## 11.2 MAGNETIC FIELD

The space around a magnetic material or a moving electric charge within which the force of magnetism can be experienced.

Unit: Tesla ( $\text{Wb/m}^2$ )

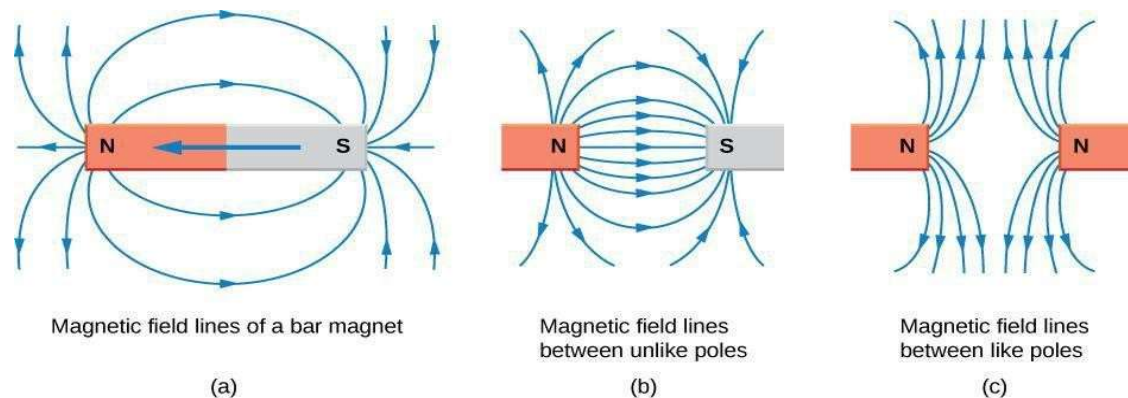

Figure 11.2

### Magnetic lines of force:

Curved lines used to represent a magnetic field, drawn such that the number of lines relates to the magnetic field's strength at a given point (Fig. 11.2).

### Properties of magnetic lines of force

- (i) The magnetic field lines of a magnet form continuous closed loops.
- (ii) The tangent to the field line at a given point represents the direction of the net magnetic field  $B$  at that point.
- (iii) Larger the number of field lines crossing per unit area, the stronger is the magnitude of the magnetic field  $B$ .
- (iv) Their density decreases with increasing distance from the poles.
- (v) The magnetic field lines do not intersect with each other.
- (vi) They flow from the South Pole to the North Pole within a material and North Pole to South Pole in air.

### Magnetic flux:

The total number of magnetic field lines crossing through given surface area  $S$  held perpendicular to direction of magnetic field  $B$ .

$$\phi = BS \cos \theta$$

Unit: The SI unit of magnetic flux is the weber (Wb)

**Magnetic Intensity:**

It is the amount of magnetic flux in a unit area perpendicular to the direction of magnetic flow.

**11.3 ELECTROMAGNETIC INDUCTION**

The induction of an electromotive force by the motion of a conductor across a magnetic field or by a change in magnetic flux in a magnetic field is called **electromagnetic induction**.

It is used in electrical motor, generator etc. to generate electricity.

\*\*\*\*\*

# UNIT-6

## SEMICONDUCTOR PHYSICS

### 12.1 ENERGY LEVEL AND ENERGY BANDS

#### Energy Levels:

In an atom, electrons cannot revolve in any direction, but are confined to well-defined energy states. These states are called **energy levels**.

There are three types of energy levels:

1. **Ground level:** This refers to the lowest energy state in the system ( $E_1$ ). Thus the completely de-excited atoms would occupy this level.

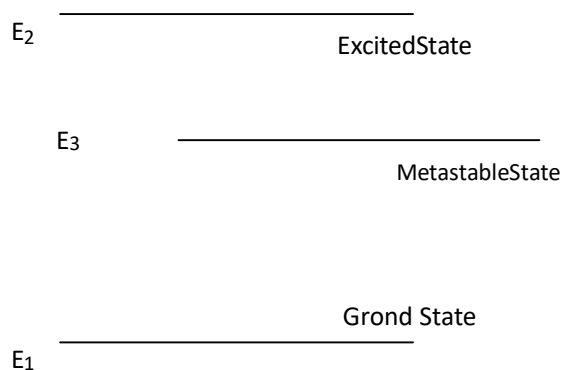

2. **Excited level:** any level above the ground state is excited state ( $E_2$ ). The atom can stay in excited state only for  $10^{-8}$  s. After this time the atom will lose its energy in the form of radiation and come back to ground state.
3. **Metastable level:** This level lies in between the excited and ground levels ( $E_3$ ). Its lifetime is 100 times more than excited state.

#### Energy Bands:

When two atoms are brought closer to form a solid, the energy levels get modified due to mutual interactions. Each energy level splits into two levels, one having energy higher than the original level and another having lower energy.

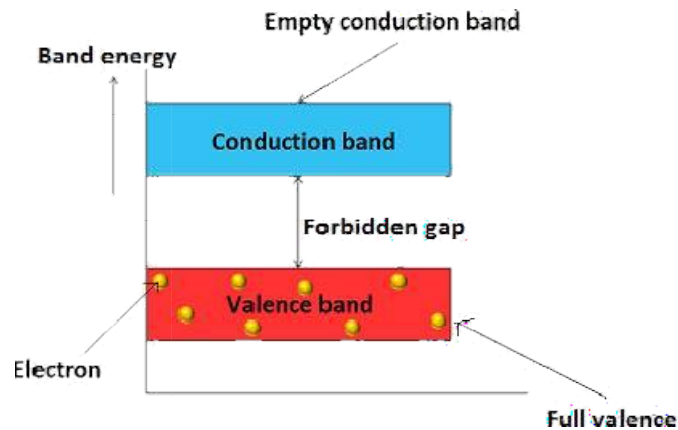

**Figure 12.1**

Now when a large number of atoms ( $n$ ) come closer to each other, each energy level splits into a large number of levels. As a result a large number of discrete but closely spaced energy levels are formed. These are called Energy Bands. The inner shells however remain unaffected by neighbouring atoms. Because they are shielded by the outer electrons of their own atoms.

The highest energy band occupied by the valence electrons is called the **valence band**. Above this band there lies an empty band called the **conduction band**. These bands are separated by an energy gap known as **Forbidden Gap ( $E_g$ )** as shown in Fig. 12.1.

## 12.2 TYPES OF MATERIALS

On the basis of the forbidden gap ( $E_g$ ), the material can be divided into following categories (Fig. 12.2).

**Insulators:** These are poor conductors of electricity. Forbidden gap for these materials is  $E_g = 5 - 6 \text{ eV}$ . The energy gap between valence band and conduction band is very large. Hence valence electrons will not be freed and no current will flow. Examples are paper, wood, plastics.

**Conductors:** Metals or good conductors are those substances which can conduct heat and electricity through them easily as there are many free electrons. In case of conductors  $E_g = 0$ , i.e. valence band and the conduction band overlap each other. Examples are Copper, aluminium, gold etc.

**Semiconductors:** The conductivity of a semiconductor lies between that of conductors and insulators. In case of semiconductors,  $E_g$  is of the order of 1 - 2 eV.

At absolute zero temperature, the conduction band is totally empty and there is no flow of current. So these materials act as insulators at room temperature. But at the higher

temperature, some valence electrons acquire sufficient energy to go in the conduction band. So at higher temperatures these materials start working as conductors. Even a small electric field can cause a flow of current in such materials. Examples are Silicon (Si), Germanium (Ge) etc.

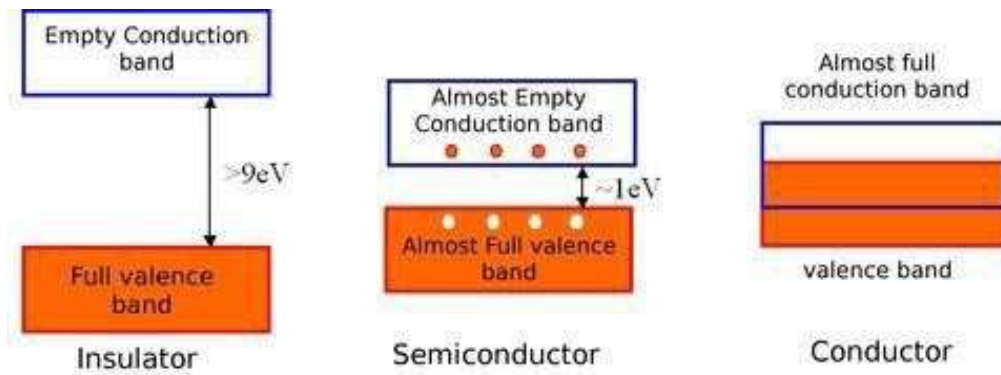

Figure 12.2

### 12.3 INTRINSIC AND EXTRINSIC SEMICONDUCTORS

**Intrinsic Semiconductors:** A semiconductor, which is quite pure and completely free from any impurity, is called an intrinsic semiconductor. E.g. Silicon (Si) and Germanium (Ge).

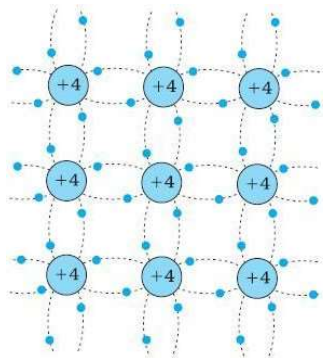

Figure 12.3

They have four valence electrons. Each of the four electrons form *covalent bond* with neighboring four atoms. By forming such covalent bonds, there is no free electron at absolute zero temperature. At room temperature some electrons break away from the covalent bond and enter into the conduction band. Each electron leaves behind a vacancy known as hole.

Hence in pure semiconductors both electrons and holes constitute current and the numbers of these two types of charge carriers are equal, i.e.  $n_e = n_h$

#### Extrinsic Semiconductors

A doped semiconductor is called an extrinsic semiconductor. The addition of a desirable impurity to a semiconductor is called **doping** and the impurity atoms added are called dopants.

#### n-Type Semiconductor:

When a small amount of pentavalent impurity (e.g. Phosphorous, Arsenic etc.) is added to an intrinsic semiconductor (Si or Ge), it provides a large numbers of free electrons. The semiconductor is then, called n-type semiconductor.

Because impurity atom has five valence electrons, four of these will form covalent bonds, but one excess electron will be left free. Hence the current carriers are electrons. Therefore majority carriers are negatively charge electrons while the holes are minority carriers.

In n-type semiconductor, number of electrons is much larger than the number of holes, i.e.  $n_e \gg n_h$

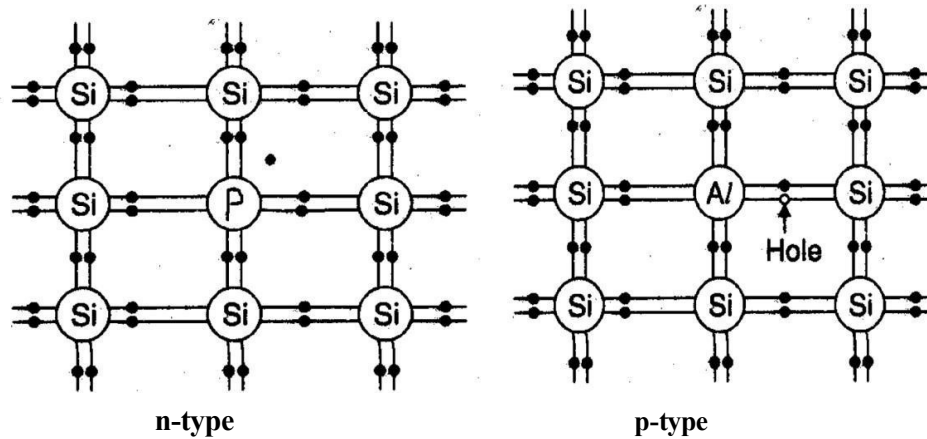

Figure 12.4

**p-Type Semiconductor:**

When a small amount of trivalent impurity (e.g. Boron, Aluminum etc.) is added to intrinsic semiconductor, it creates a large number of holes in valence band. The semiconductor is called a p-type semiconductor.

When a trivalent impurity is added to a semiconductor, its three valence electrons form covalent bonds with three neighbouring atoms, while the fourth bond has a deficiency of electron. Thus there is a vacancy, which acts as a hole that tends to accept electrons.

The number of holes is greater than the number of electrons, i.e.  $n_h \gg n_e$

Hence, in p-type semiconductors, holes are the majority carriers and electrons are the minority carriers.

**p-n Junction Diode**

A single crystal of silicon or germanium that has been doped in such a way that half of it is a p-type and the other half an n-type semiconductor is known as a p-n junction diode. The junction is called a p-n junction as shown in Fig. 12.5.

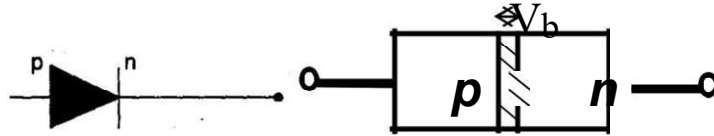

Figure 12.5

### Characteristics of p-n Junction Diode

The graph showing the variation of the current flowing through the junction, when the voltage is applied across the junction diode in forward biased and reverse biased, is known as characteristic curve of a p-n junction diode.

**Forward bias characteristic:** The p-n junction diode is said to be forward biased if the positive terminal of battery is connected to the p-type and the negative terminal to the n-type of semiconductor as shown in Fig. 12.6.

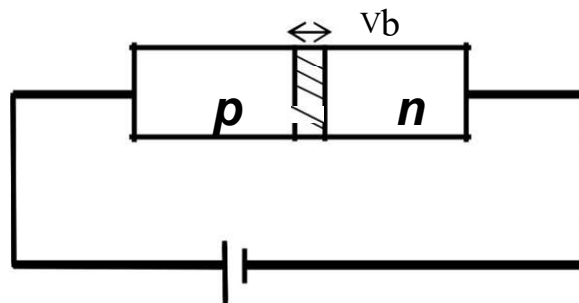
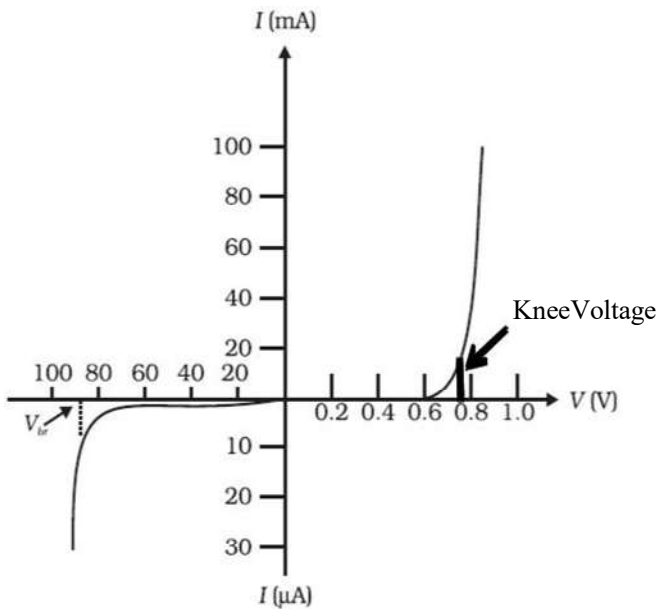

Figure 12.6



Let  $V$  is the voltage applied. This pushes the majority carriers, the holes in the p-type and electrons in the n-type towards the p-n junction.

If  $V > V_B$ , then the majority carriers from both sides are able to diffuse across the junction and a current is set up in the circuit. This process decreases the thickness of the depletion layers. The diode offers a low resistance to the flow of current.

A minimum amount of voltage required so that a current start flowing is known as the knee voltage. The current starts

**Figure12.7**

**Reverse bias characteristic:**

The p-n junction diode is said to be reverse biased if the negative terminal of the external source is connected to the p-type and the positive terminal to the n-type of semiconductor as shown in Fig 12.8.

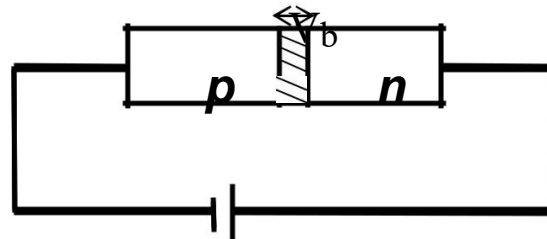

**Figure12.8**

The external voltage pulls the majority carriers holes in the p-type crystal and the electrons in the n-type crystal away from the junction. This increases the width of depletion layer. The diode offers very high resistance and no current is set up across the junction due to majority carriers. However a small current may be there across the junction due to minority carriers. It is called leakage current ( $I_s$ ).

**12.4 DIODE AS A RECTIFIER**

The rectifier is an electronic device used to convert alternating current (AC) into direct current (DC).

**Half wave rectifier:**

Half wave rectifier convert AC into DC for only half of the input cycle. The circuit diagram for half wave rectifier using the p-n diode is as shown. During the first half cycle of AC the diode operates under a forward bias and current flows through the load  $R_L$ . During the other half, the diode becomes reverse biased and no current flows through the load  $R_L$ . Thus we get a rectified, unidirectional current across  $R_L$  and only half of the AC signal wave is rectified. The half wave rectifier gives output only for half cycle, hence power loss is high.

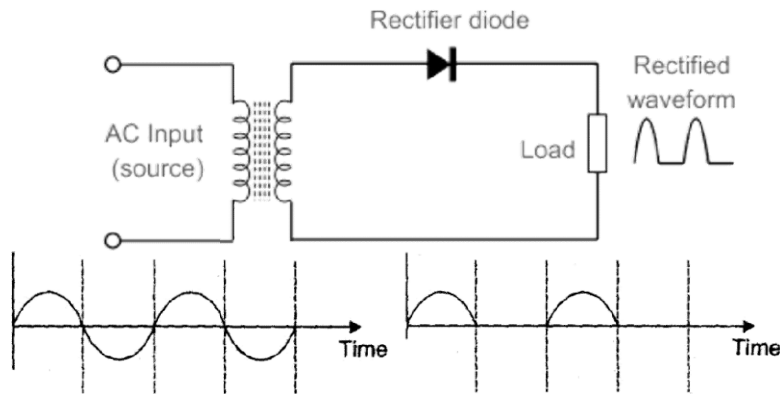

Figure 12.9

**Full waverectifier:**

Full waverectifier converts AC in to DC for complete cycle of input wave. The circuit diagram for full wave rectifier is shown. The center tap transformer is used. Two diodes are connected across the secondary of the transformer, the middle point of which is tapped at T. During the first half of the AC cycle, one end of the secondary say A becomes positive and B becomes negative. Diode D<sub>1</sub> is forward biased and diode D<sub>2</sub> is reverse bias. Thus a current flows through the diode D<sub>1</sub>.

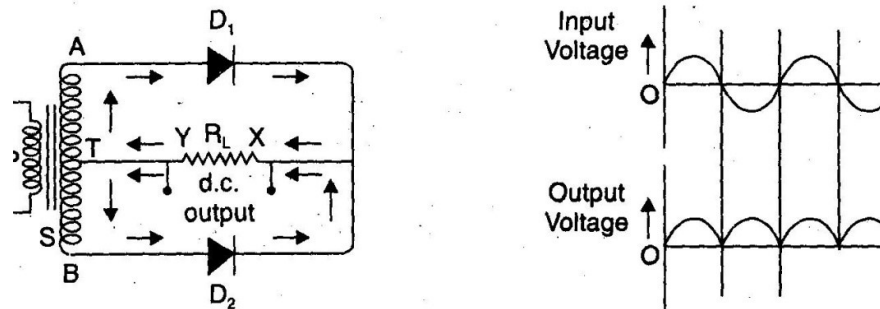
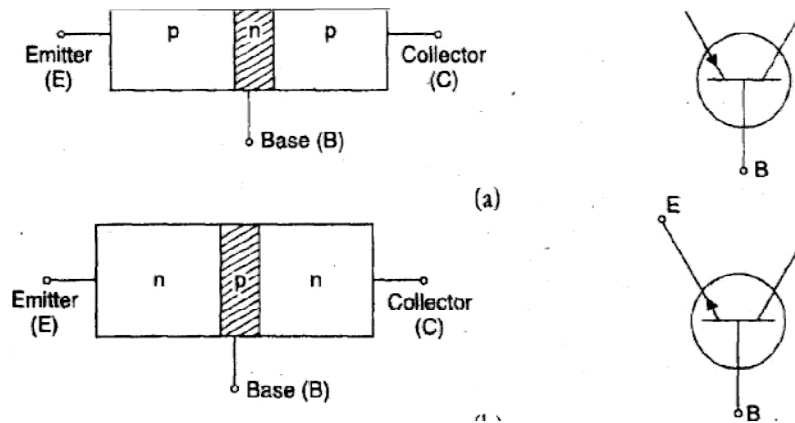

Figure 12.10

During the other half of AC cycle, end B becomes positive and the end A negative and the current flows through the diode D<sub>2</sub>. Thus during both halves, the current through the load R<sub>L</sub> is in the same direction and full wave rectification of AC is achieved.

**12.5 SEMICONDUCTOR TRANSISTOR**

The transistor is composed of three semiconductor elements. The three elements are combined in such a way that if n-type semiconductor is sandwiched between two p-type semiconductors. This is known as p-n-p transistor. So basically transistor is combination of two pn-junctions joined back to back (Fig. 12.11).



**Figure12.11**

If p-type semiconductor is sandwiched between two n-type semiconductors then this is known as n-p-n transistor. In the circuit symbols of a transistor, only emitter has an arrow to indicate that it is the supplier electrode. It also indicates the direction of flow of current.

- The three elements of the transistor are; emitter(E), collector(C)and base(B).
- The emitter supplies the majority carriers for transistor current flow. The collector collects current and the base controls the passage of electrons from the emitter to collector.
- The doping level in the emitter is more than in the collector.
- The base is thin and lightly doped.
- Collector is moderately doped.
- Area of emitter is moderate ,base is minimum and collector is maximum.
- In normal operation of a transistor, the emitter-base junction is always forward-biased whereas the collector-base junction is reverse-biased.

\*\*\*\*\*

## UNIT-7

### MODERN PHYSICS

#### 13.1 LASER

LASER is an acronym for **Light Amplification by Stimulated Emission of Radiation**. It is a beam of light which is coherent, monochromatic, highly directional and very intense.

**Energy Level** : In an atom, the electrons are confined to well defined energy states. These states are called as energy level(Fig. 13.1).

There are three type of energy levels:

1. **Ground level:** This refer to the lowest energystate in the system( $E_1$ ). The completely de-excited atoms would occupy this level.



**Figure 13.1** Energy levels

2. **Excited level:** Any level above the ground state is excited state ( $E_2$ ). The atom can stay in excited state only for a very short time varying from  $10^{-8}$  to  $10^{-10}$  s. After this time the atom will lose its energy in the form of radiations and come back to ground state.
3. **Metastable level:** This level lies in between the excited and ground levels ( $E_3$ ). Its lifetime is 100 times more than excited state and atom can stay in this state for a longer time.

## The Emission Process

When a material is energized by some radiations, the atoms of the material get excited to the higher state from ground state. These excited atoms may lose energy and come back to ground state. The energy loss may be in the form of heat, light or X-rays etc. This process may take place in two ways:

### I. Spontaneous Emission:

Spontaneous emission is the process of light emission in which the atoms in excited state ( $E_1$ ) come back to ground state ( $E_0$ ) after  $10^{-8}$  seconds, without any external radiation (see Fig. 13.2). The atoms in excited state, release **radiation of energy  $h\nu = E_1 - E_0$**  in the form of photons. These photons are emitted in random directions.

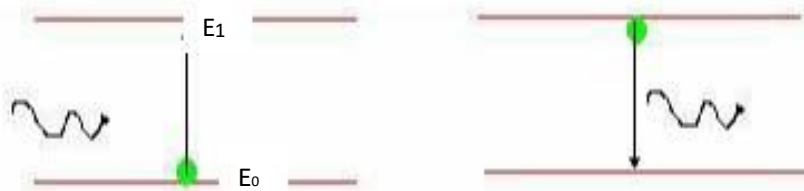

Figure 13.2 Spontaneous emission process

### II. Stimulated Emission:

If an excited atom is irradiated with a photon having energy  $h\nu = E_1 - E_0$  before the spontaneous emission process, then the excited atom will lose the energy in the form of two photons as shown in Fig. 13.3. This process occurs in such a way that the incident photon and the emitted photon are found to be moving with the same momentum and phase. This kind of emission is called stimulated emission.

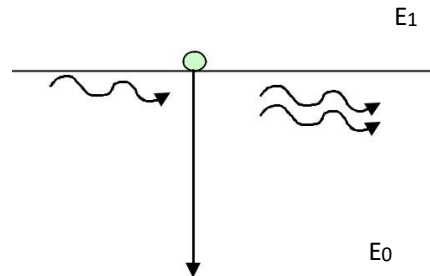

Figure 13.3 Stimulated emission process

## Population Inversion:

In a material, when the number of atoms in an excited state ( $N_2$ ) becomes more than the number of atoms in the ground state ( $N_1$ ), this condition is known as Population Inversion. This condition is a must for stimulated emission.

## Characteristics of Laser

Laser light has four unique characteristics that differentiate it from ordinary light:

### a) Coherence

The photons emitted from ordinary light sources have different phases and hence are non-coherent. While in a laser, all the emitted photons have the same phase or constant phase.

difference. Thus the laser light is highly coherent in nature. Because of this coherence, a large amount of power can be concentrated in a narrow space.

#### **b) Monochromatic**

In laser, all the photons emitted have the same frequency, or wavelength. Hence, the laser light has single wavelength or color. Therefore, laser light covers a very narrow range of frequencies or wavelengths. Hence the light emitted by a laser is highly monochromatic.

#### **c) Directionality**

In ordinary light sources (lamp, torch), photons will travel in random direction. Therefore, these light sources emit light in all directions. But, in laser, all photons will travel in same direction. Therefore, laser emits light only in one direction. This is called directionality of laser light. As a result, a laser beam can travel to long distances without spreading.

If an ordinary light travels a distance of 2 km, it spreads to about 2 km in diameter. On the other hand, if a laser light travels a distance of 2 km, it spreads by less than 2 cm.

#### **d) High Intensity**

In laser, the light spreads in small region of space and in a small wavelength range. Hence, laser light has greater intensity when compared to the ordinary light. Even a 1 milli watt laser would appear many thousand times more intense than 100 Watt ordinary lamp.

### **Applications of Lasers:**

- Laser welding: Lasers can be used for spot welding, seam welding, inert gas laser welding and welding of non-metals.
- Laser cutting: Metals can be cut with output power of at least 100 W to 500 W. Wide range of materials can be cut e.g. paper, cloth, plywood, glass, ceramics, sheet metal like steel, titanium, aluminium etc.
- Laser drilling: Lasers are used for fine drilling
- Lasers are used for accurate measurement of the order of 0.1 m to the extent of distant object.
- Lasers are used to produce thermonuclear fusion.
- These are used to study the chemical process, nature of chemical bonds, structure of molecule and scattering.
- Long distance communication by using optical fibre and laser is very efficient.
- In medicine, lasers are used to study many biological samples, treatment of liver and to remove tumors.
- Laser is used for printing. Laser printers are very fast and efficient. The quality is very high.
- In computers, we use laser disc. In CD writer, a tiny laser beam burns a spot on the compact disc.

## **13.2 OPTICAL FIBRE**

An optical fibre consists of a very thin core made of glass or silica having a radius of the order of micrometers ( $10^{-6}$  m). The core is covered by a thin layer of cladding material of lower refractive index. Such optical fibres can transmit a light beam from one end to the other without significant energy loss. These are generally made from transparent materials such as glass (silica) or glass like polymers.

The branch of physics dealing with the propagation of light through optical fibres is known as **fiberoptics**

**Principle:** It is based on the phenomenon of total internal reflections at the glass or silica boundary. The light will reach at other end even if the fibre is bent or twisted.

If a ray of light travelling from a denser medium into a rarer medium, and the angle of incidence is greater than the critical angle, the ray is totally reflected back into the same media. This phenomenon is called as **total internal reflection**.

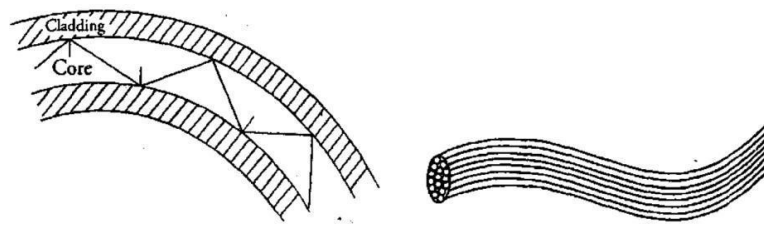

Figure 13.4 Schematic of optical fibre

**Fibre Types**

On the basis of mode of propagation the fibre can be classified as:

**Mono mode fibre:** It has a very narrow core of diameter about 8-12  $\mu\text{m}$  or less and **Multi mode fibre:** It has a core of the cladding is relatively big 125  $\mu\text{m}$  as relatively large diameter such as 50-200 shown in Fig. 13.5(a). As then a  $\mu\text{m}$  as shown in Fig. 13.5(b). As the name implies, mono mode fibre sustains only one mode of propagation that is why it is also hundreds of modes of propagation known as single mode fibre. simultaneously. These signals do not intermix with each other. This is most commonly used optical fibre.

**Numerical Aperture (NA):** It is the light collecting ability of an optical fiber. It depends on difference in refractive index of core and cladding. Generally, value of NA ranges from 0.1 to 0.5 for most of the commonly used optical fibres.

**Applications of Optical Fibres:**

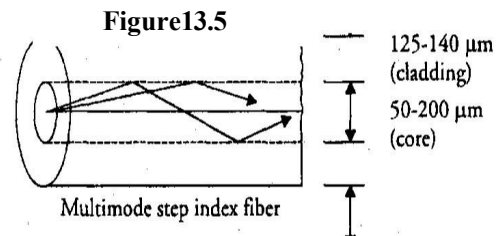
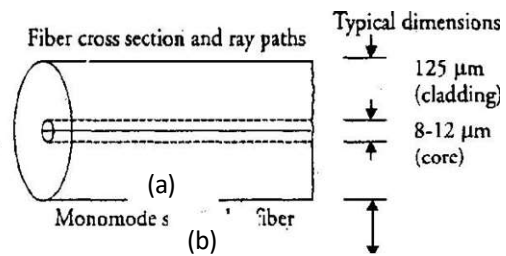

- With the help of light pipes made up of flexible optical fibres, it is possible to examine the inaccessible parts of equipment or of the human body. For example in endoscopy, a patient's stomach can be viewed by inserting one end of a light pipe into the stomach through mouth.
- Optical fibres are also used for transmitting and receiving electrical signals that are converted to light by transducers.
- These are used as transmission medium to transmit communication signals at high data rates over long distances. For example, more than 100000 telephone signals at data rate of Gigabits/sec can be simultaneously transmitted through a typical single pair of optical fibre.
- Optical fibres are also being extensively used for cable TV networks and local area networks (LAN) in premises.

The quality of the signal transmitted with optical fibres is much better than other conventional methods.

### 13.3 NANOTECHNOLOGY

*It is the branch of technology that deals with use of nanomaterials with dimensions less than 100 nanometres, especially the manipulation of individual atoms and molecules.*

#### **Nanomaterials:**

These are materials with any dimension in the nanoscale (1 nm to 100 nm). These materials are very reactive and exhibit unique physical, chemical and biological properties due to high surface-to-volume ratio.

**Example:** Carbon nanotube, nano particle, quantum dots, nano polymers, nano shell, nano pores, nano rod, nanowires, nanopowder, fullerene, etc.

#### **Applications of Nanotechnology**

Nanomaterials are of interest because of their unique optical, magnetic, electrical, and other properties. These emergent properties have the potential for great impacts in electronics, medicine, and other fields.

- **Medicine:** Nanotechnology based drugs are being used to treat dangerous diseases like cancers and prevent health issues more effectively, as customized nano particles can deliver drugs directly to diseased cells in the body. New nanoparticles based chemotherapy drugs that can be delivered directly to cancer cells for better treatment are under development.
- **Electronics:** Electronic devices made with nano-fabrication techniques help in reducing weight and power consumption. This also improves display screens on electronic devices and increasing the density of memory chips. Nanotechnology can help to reduce the size of transistors and other components used in integrated circuits.

- **Food Industry:** Developing new nanomaterials will not only make a difference in the taste of food, but also in improving the food production, nutrient value and preservation.
- **Fuel Cells:** Nanotechnology is being used to reduce the cost of catalysts, used in fuel cells to produce hydrogen ions from fuel such as methanol. Nanomaterials are also being developed to improve the efficiency of membranes used in fuel cells.
- **Solar Cells:** Nano technology based solar cells can be manufactured at significantly lower cost with better efficiency as compared to conventional solar cells.
- **Space:** Advancements in development of nano-composites make lightweight spacecrafts. Carbon nano tubes based cables have been proposed for the space elevators.
- **Fuels:** Nano technology can be used for production of fuels from low grade raw materials which are economical and also increase the efficiency of engines.
- **Catalyst:** Nano particles have a greater surface area to interact with the reacting chemicals than catalysts made up of larger particles. This allows more chemicals to interact with the catalyst simultaneously and hence makes the catalyst more effective.
- **Chemical Sensors:** Nanotechnology based sensors can detect very small amounts of chemical vapors. Various types of nanostructures such as carbon nanotubes, graphene, zinc oxide nanowires can be used as detecting elements in nanotechnology based sensors.
- **Fabric:** Making composite fabric with nano-sized particles or fibres allows improvement of fabric properties without a significant increase in weight, thickness, or stiffness.
- **Environment:** Nanotechnology is being used in cleaning water and existing pollution, improving manufacturing methods to reduce the generation of new pollution, and making alternative energy sources more cost effective.

\*\*\*\*\*