

POWER STATION ENGG.

TH-3

6th SEM

MECHANICAL ENGG.

Under SCTE&VT, Odisha

PREPARED BY



Er. Sarbeswar Rout

LECTURER, Dept of MECH, KALINGA NAGAR POLYTECHNIC.

TARAPUR, JAJPURROAD

Notes on Power Plant Engineering

6th Semester Diploma

Mechanical Engineering

1.1.1 Conventional Energy Sources

These are commercial forms of energy available. They include the following:

- (i) Fossil fuel that may be in solid, liquid or gaseous forms
- (ii) Water power or energy stored in water
- (iii) Nuclear energy

Worldwide consumption of total energy is as shown in the Table 1.1.

Table 1.1 *Worldwide Consumption of Total Energy*

Source of energy	Contribution (%)	Overall contribution (%)
Coal	32.5	–
Oil	38.3	–
Gas	19.0	92
Uranium	0.13	–
Hydro	2.00	–
Wood	6.6	8

(Continued)

Table 1.1 (Continued)

Source of energy	Contribution (%)	Overall contribution (%)
Dung	1.2	–
Waste	0.3	–

From Table 1.1, it is evident that 92 per cent of total energy comes from coal, oil, gas, and uranium, and hence these are the most commonly used commercial energy sources.

1. Coal

It is the most common source of energy that is being used since industrialization. Modern steam boilers burn coal mainly as primary fuel in any of its available forms. Different ranks of coal available are peat, lignite, bituminous and anthracite.

Figure 1.1 shows a thermal power plant using steam as a working fluid. It consists of a steam generator, a condensing turbine coupled to a generator, a condenser with a condensate extraction pump and a feed water tank with a feed pump.

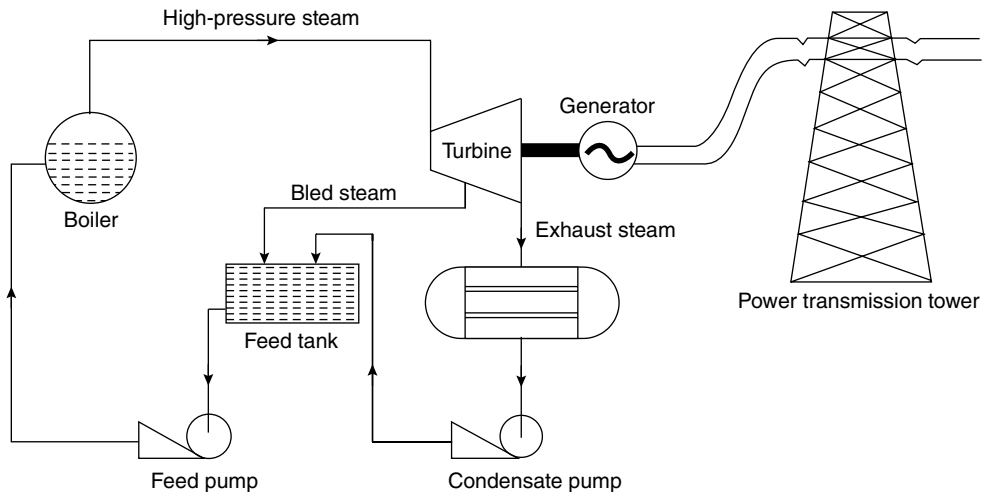
**Fig. 1.1** A Typical Thermal Power Plant

In a coal-fired thermal power plant, coal is burnt in a boiler furnace. The heat generated is utilized to convert water, which is the working fluid, into superheated steam in the boiler or steam generator. The high-pressure steam is used to run the prime mover (steam turbine). The prime mover rotates along with an electrical generator coupled to it. Thus, mechanical energy is converted into electrical energy that is supplied to various points using power feeders. The steam that expands in the turbine is condensed into water in a surface condenser. The condensate water is pumped back to the feed tank. The feed water in the feed tank is heated by bleeding some amount of steam from the turbine. The hot feed water is pumped to the boiler using a feed pump.

4 Power Plant Engineering

According to estimates, coal reserves are sufficient enough to last for 200 years. However, coal reserves have lower calorific value, and their transportation is uneconomical. When burnt, they produce pollutants such as CO and CO₂, and hence they are responsible for ecological imbalance.

2. Oil

Almost 40 per cent of energy needs is met by oil alone. With present consumption and a resource of 250,000 million tons of oil, it is estimated to last for only 100 years, unless more oil is discovered. Major chunk of oil comes from petroleum.

3. Gas

Due to the non-availability of ready market gas is not completely and effectively utilized and is burnt in huge quantities. Its transportation cost is much higher than oil. Large reserves are estimated to be located in inaccessible areas. Gaseous fuels are classified as follows:

- (i) Gases of fixed composition such as acetylene, ethylene, methane, etc.
- (ii) Industrial gases such as producer gas, coke oven gas, blast furnace gas, water gas, etc.

4. Agricultural and organic wastes

These include saw dust, bagasse, garbage, animal dung, paddy husk, corn stem, etc., accounting for a major energy consumption.

5. Water

It is one of the potential sources of energy meant exclusively for hydro-electric power generation. Potential energy of water is utilized to convert it into mechanical energy by using prime movers known as hydraulic turbines. The operating cost of the plant is cheaper as compared to other types of power plants. It is the only renewable non-depleting source of energy that does not contribute to pollution.

Figure 1.2 shows a hydraulic power plant designed for high head. In a hydro-electric power plant, water is stored behind a dam that forms a reservoir. Water is taken from the reservoir through tunnels from where it is distributed to *penstocks*. A penstock is a large diameter pipe that carries water to the turbine. Trash racks are fitted at the inlet of tunnels to prevent any foreign matter from entering into the tunnels. A surge tank built before the valve house prevents sudden pressure rise in the penstock when the load on the turbine decreases or when the inlet valves to the turbine suddenly get closed. The flow of water in the penstocks is controlled in the valve house that is electrically driven. Thus, potential energy of water is utilized to run the prime mover (hydraulic turbine) coupled to an electric generator in the power house. After doing work, the water is discharged to the tail race.

6. Nuclear power

Any matter consists of atoms held together by means of binding energy. Controlled fission of heavier unstable atoms such as U₂₃₅, Th₂₃₂ and Pu₂₃₉ liberates enormous amount of energy. This is possible only by utilizing small amount of nuclear fuels. It may be noted that the energy released by fission of one kilogram of U₂₃₅ is equivalent to the heat generated by burning 4,500 kg of coal. This factor makes the nuclear energy more attractive. The energy generated during nuclear fission reaction is used to produce steam in heat exchangers, which is utilized to run the turbo-generators.

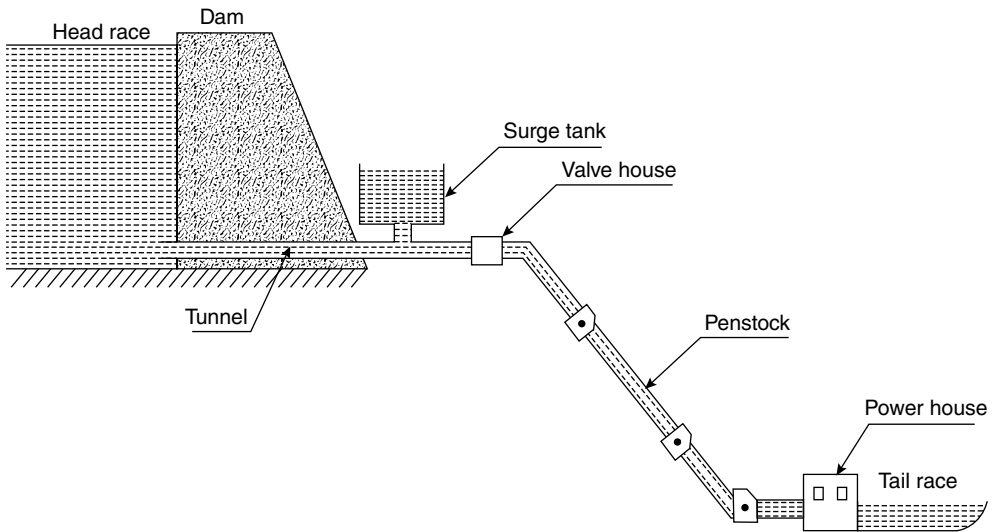

Fig. 1.2 A Hydraulic Power Plant

For nuclear power generation, three systems are considered. The first is based on natural uranium yielding power and plutonium. The second is by using plutonium and depleted uranium in a fast breeder reactor. The third system is by using thorium and converting it into uranium in a fast breeder reactor. India has uranium reserves only enough to produce 6×10^6 kW of energy that is a meager 1 per cent of its current energy requirements.

1.1.2 Non-Conventional Energy Sources

1. Solar energy

Solar energy has the greatest potential of all the sources of renewable energy that comes to the earth from sun. This energy keeps the temperature of the earth above that in colder space, causes wind currents in the ocean and the atmosphere, causes water cycle and generates photosynthesis in plants. The solar energy reaching the surface of the earth is about 10^{16} W, whereas the world-wide power demand is about 10^{13} W. This means solar energy gives us 1,000 times more energy than our requirement. Even if we use 5 per cent of this energy, it is more than 50 times out requirement. The total solar radiation absorbed by the earth and its atmosphere is 3.8×10^{24} J/yr. Figure 1.3 shows a concentrating type solar collector used to trap solar energy.

2. Wind energy

Wind energy can be economically used for the generation of electrical energy. Winds are caused by two main factors:

- (i) Heating and cooling of the atmosphere which generates convection currents. Heating is caused by the absorption of solar energy on the earth's surface and in the atmosphere.
- (ii) The rotation of the earth with respect to atmosphere and its motion around sun.

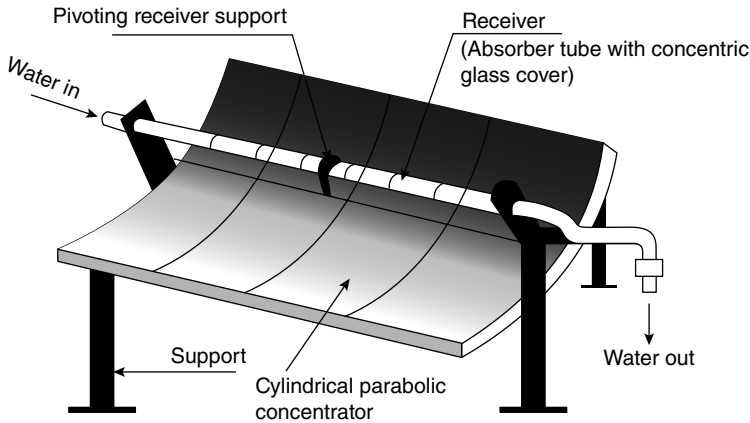

Fig. 1.3 A Concentrating-Type Solar Collector

The energy available in the winds over the earth’s surface is estimated to be 1.6×10^7 MW, which is almost the same as the present-day energy consumption. Wind energy can be utilized to run windmill that in turn is used to drive to generators. India has a potential of 20,000 MW of wind power.

The energy available in the winds over the earth’s surface is estimated to be 1.6×10^7 MW, which is almost the same as the present-day energy consumption. Wind energy can be utilized to run windmill that in turn is used to drive the generators. India has a potential of 20,000 MW of wind power.

Due to pressure differential existing between any two places on earth, air moves at high speed. This pressure differential is caused due to earth’s rotation and by uneven heating of the earth by sun. The kinetic energy of air can be utilized to generate electric power. The kinetic energy per unit volume of moving air is given by the following equation:

$$E = \frac{1}{2} \rho V^2$$

where ρ is the density of air and V = average linear speed.

Figure 1.4 shows a typical windmill where water can be pumped out for irrigation and drinking purpose. Here the rotational motion of the wheel can be either translated into rotary motion (to generate electricity) or reciprocating motion (to drive the pump).

3. Energy from biomass and biogas

Bio-mass means organic matter that is produced in nature through photosynthesis. In the presence of solar radiation, water and carbon dioxide are converted into organic material, CH_2O .

CH_2O is stable at low temperature, it but breaks at higher temperature releasing heat equal to 469 kJ/mole.

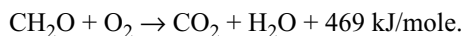

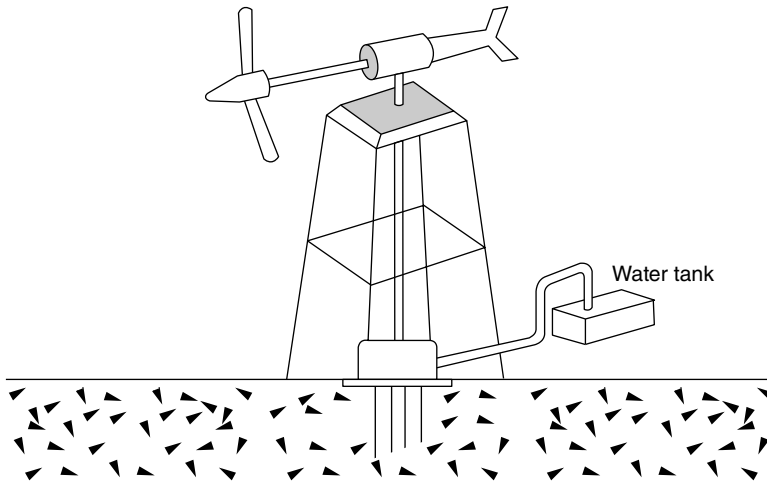

Fig. 1.4 A Typical Windmill

It is possible to produce large amount of carbohydrate by growing plants such as algae in plastic tubes or ponds. The algae could be harvested, dried and burned for production of heat that could be converted into electricity by conventional methods. The biomass can be either used directly by burning or can be processed further to produce more convenient liquid or gaseous fuels.

Three different categories of bio-mass resources are as follows:

- (i) **Bio-mass in its traditional solid mass** such as wood and agricultural wastes that are burnt directly to get energy.
- (ii) **Bio-mass in its non-traditional form** in which bio-mass is converted into ethanol and methanol that are used as liquid fuels in engines.
- (iii) **Bio-mass in fermented form** in which biomass is fermented anaerobically to obtain a gaseous fuel called biogas that contains 55 – 65 per cent methane, 30 – 40 per cent CO_2 and rest as impurities such as H_2 , H_2S and some N_2 .

Various resources of bio-mass are as follows:

- (i) Concentrated waste – municipal solids, sewage wood products, industrial waste and manure of large lots.
- (ii) Dispersed waster residue – crop residue, logging residue and disposed manure.
- (iii) Harvested biomass, stand by bio-mass and bio-mass energy plantation.

Total solar radiation absorbed by plants is about 1.3×10^{21} J/yr and world's standing bio-mass has an energy content of about 1.5×10^{22} J.

4. Energy from oceans

A large amount of solar energy is collected and stored in oceans. The surface of water acts as a collector for solar heat, while the upper layer of the sea constitutes infinite heat storage

reservoir. The heat contained in the oceans could be converted into electricity due to the temperature difference (20–25 K) between the warm surface water of the tropical oceans and the colder waters in the depths. This is the basic idea of OTEC systems. The surface water that is at higher temperature could be used to heat some low-boiling-point organic fluid, the vapours of which would run a heat engine. The amount of energy available from OTEC is enormous, and is replenished continuously.

Figure 1.5 shows an OTEC plant. In this plant, sea water acts as a heat source, working fluid, coolant and heat sink. The warm surface water at 27°C is used to boil a low-boiling-point liquid, the vapours of which run a turbine. The working fluid may be ammonia, propane or freon operating at a pressure of about 10 bar.

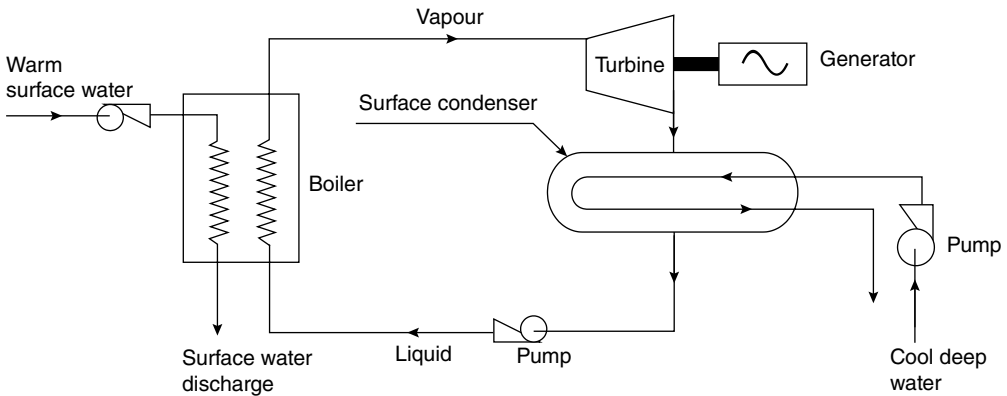

Fig. 1.5 An OTEC Plant

Disadvantages

- (i) Efficiency is extremely low, and hence the system needs extremely large power plant heat exchangers and components.
- (ii) Even though there is no fuel cost, the capital cost is very high, and hence the unit power cost is higher.
- (iii) Involves developmental problems and uncertainties of market penetration.

5. Tidal energy

Due to universal gravitational effects of sun and moon on the earth tides in the sea are generated. Due to fluidity of water mass, there results periodic rise and fall of water level during the rising and setting of sun and moon. This periodic rise and fall of water level results in tidal power. When the water is above the mean sea level, it is called flood tide (high tide); and when the water is below the mean sea level, it is known as ebb tide (low tide). The energy dissipated with slowing down the rotation of the earth as a result of tidal action is about 10^{26} J/yr.

The tides are rhythmic but not constant. Their occurrence is due to a balance of forces, mainly gravitational force of the moon and sun to some extent, balancing the centrifugal force on water due to earth rotation. This results in rhythmic rise and fall of water. The moon rotates

around the earth every 24 hr 50 min. During this period, tide rises and falls twice, resulting in a tidal cycle lasting for 12 hr 25 min. Thus, the tidal range R is given by the following relation;

$$R = \text{water elevation at high tide} - \text{water elevation at low tide.}$$

This range is maximum during new and full moons and is known as spring tide and neap tide.

To harness tides, a dam is built across the mouth of the bay with large gates and low head hydraulic reversible turbines (Figure 1.6). A tidal basin formed thus gets separated from the sea, by dam. There always exists a difference between the water levels on either side of the dam during low tide and high tide. Thus, the reversible water turbine runs continuously producing power by using the generator connected to it.

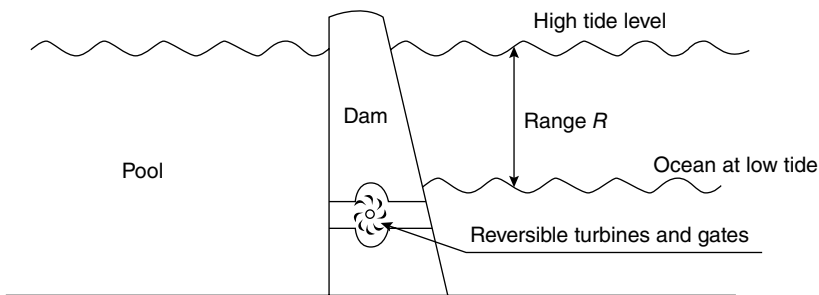

Fig. 1.6 A Tidal Energy Harnessing Plant

6. Wave energy conversion

Waves are caused by wind that in turn is caused by the uneven solar heating and subsequent cooling of the earth's crust and the rotation of the earth. When at its most active stage, wave energy produces more power than incident solar energy at its peak.

Total energy of waves is the sum of potential and kinetic energies. The potential energy arises from the elevation of the water above the mean sea level. The kinetic energy of the wave is that of the liquid between two vertical planes perpendicular to the direction of wave propagation x and placed one wavelength apart.

Figure 1.7 shows a typical wave energy conversion system. It consists of a square float that moves up and down with the water guided by four vertical manifolds. The platform is stabilized within the water by four large underwater floatation tanks supported by buoyancy forces that restrict the vertical or horizontal displacement of the platform due to wave action. Damping fins may be used so that the platform is stationary in space even in heavy seas.

A piston attached to the float moves up and down the cylinder. The cylinder is attached to the platform, and hence is stationary. The piston-cylinder arrangement acts as a reciprocating air compressor. The downward motion of the piston draws air into the cylinder via an inlet check valve. The upward motion compresses the air and sends it through an outlet check valve to the four underwater floatation tanks via the four manifolds. The four floatation tanks serve the dual purpose of buoyancy and air storage, and the four vertical manifolds serve the dual purpose of manifolds and float guides. The compressed air in the buoyancy-storage tanks is in turn used to drive an air turbine that drives an electrical generator. The electric current is transmitted to the shore via an underground cable.

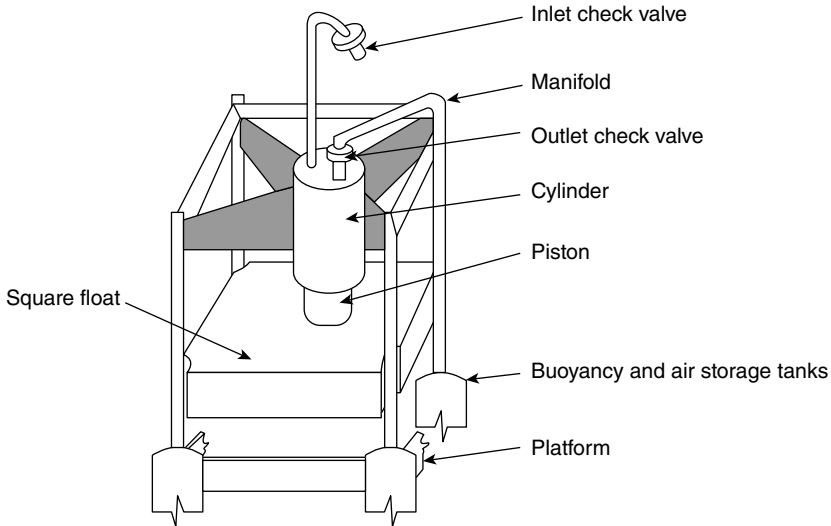

Fig. 1.7 A Typical Wave Energy Conversion System

7. Geothermal energy

This is the energy that comes from within the earth's crust. In some locations of the earth, the steam and hot water comes naturally to the surface. For large-scale use, bore holes are normally sunk with depth up to 1,000 m releasing steam and water at temperatures 200–300°C and pressure up to 3,000 kN/m². Two methods are generally used to generate power using geothermal energy.

Method I

In this method, the heat energy is transferred to a working fluid that operates the power cycle. It is found that molten interior mass of earth vents to the surface through fissures at temperatures ranging between 450 and 550°C.

Method II

In this method, the hot geothermal water and/or steam is used to operate the turbines directly. From the well head, steam is transmitted by using pipes of 1 m diameter over distances up to 3,000 m to the power plant. In this system, water separators are used to separate moisture and solid particles from steam.

The heat flux from the earth's interior through the surface is 9.5×10^{20} J/yr. The total amount of heat stored in water or steam to a depth of 10 km is estimated to be 4×10^{21} J and that stored in the first 10 km of dry rock is around 10^{27} J. Figure 1.8 shows a typical geothermal field.

8. Hydrogen energy

Hydrogen as an energy is another alternative for conventional fuels. It can be easily produced from water that is available abundantly in nature. It has the highest energy content per unit of mass of any chemical fuel and is a better substitute for hydrocarbons, with increased combustion efficiency. It is non-polluting and can be used in fuel cells to produce both electricity and useful heat. However, it has technical problems such as production, storage and transportation.

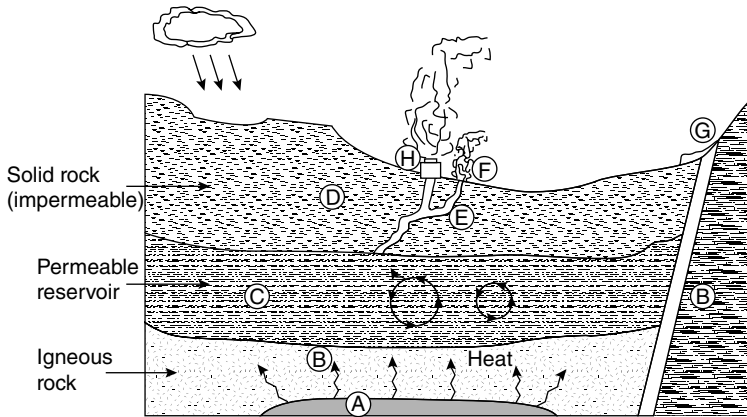

Fig. 1.8 A Typical Geothermal Field: F-fumaroles; E-fissures; H-Well; G-Hot springs

9. Fuel cells

These are electrochemical devices that are used for the continuous conversion of the portion of the free energy change in a chemical reaction to electrical energy. It operates with continuous replenishment of the fuel, and the oxidant at active electrode area and does not require recharging.

Main components of a cell are (i) a fuel electrode, (ii) an oxidant or an air electrode, and (iii) an electrolyte. Some of the fuel cells used are hydrogen, oxygen (H_2 , O_2), hydrazine (N_2H_4 , O_2), carbon/coal (C , O_2) methane (CH_4 , O_2), etc.

Figure 1.9 shows a typical hydrogen–oxygen cell popularly known as a *hydrox cell*. It consists of two porous or permeable electrodes made up of either carbon or nickel immersed

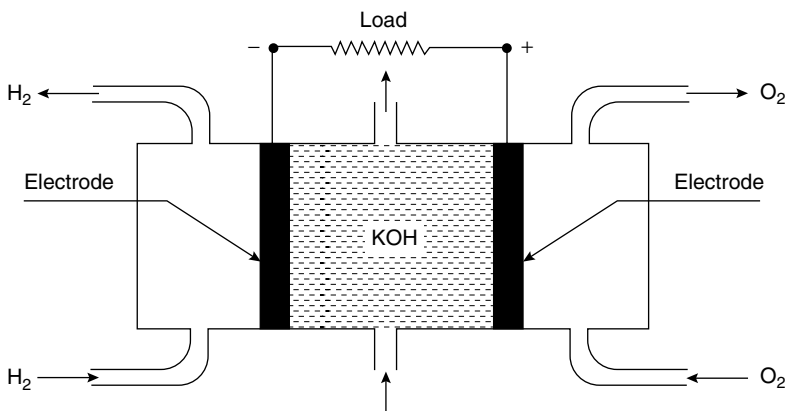

Fig. 1.9 A Hydrox Cell

in an electrolyte of KOH solution. Since the electrochemical reaction at the porous electrode where gas, electrolyte and electrode in contact are slow, a catalyst (finely divided platinum or platinum such as material) is embedded in the electrodes. The concentration of KOH solution is maintained at about 30–40 per cent, since it has higher thermal conductivity and less corrosive compared to acids.

Working principle:

At the negative electrode, hydrogen gas is converted into hydrogen ions releasing free electrons.



Under the influence of the catalyst in the electrode, the hydrogen ions react with the hydroxyl ions in the electrolyte to form water:



When the cell is operating, the free electrons from negative electrode flow through the external load towards the positive electrode. The electrons interact with oxygen and water in the electrolyte to form negatively charged hydroxyl ions:



The hydrogen and hydroxyl ions then combine to form water:



A single hydrogen–oxygen cell can produce an electromagnetic force (emf) of 1.23 V at atmospheric pressure and at a temperature of 298 K. By combining the cells in series, it is possible to generate power ranging between a few kilo-watts to mega-watts.

Advantages

- (i) Since power conversion is a direct process, the conversion efficiency is as high as 70 per cent.
- (ii) It is pollution free when operated using hydrogen and operates with minimum noise.
- (iii) It is compact in size and lighter in weight.
- (iv) Maintenance cost is less due to lesser mechanical components.

Disadvantages

- (i) It involves higher initial cost.
- (ii) It has lower voltage.
- (iii) It has lower service life.

10. *MHD generators*

MHD generators are used for direct conversion of thermal energy into electrical energy (Figure 1.10). They work on Faraday principle. When an electric conductor moves across a magnetic field, a voltage is induced in it, which produces an electric current. In MHD generators, the solid conductors are replaced by a fluid that is electrically conducting. The working fluid may be either an ionized gas or liquid metal. The hot, partially ionized and compressed gas is expanded in a duct, and forced through a strong magnetic field, electrical potential is

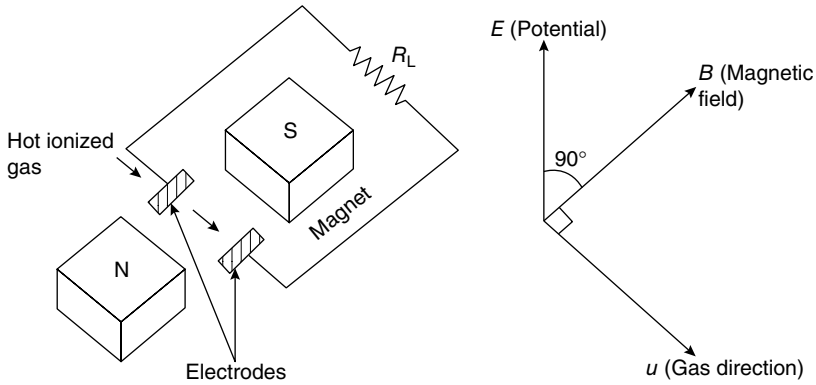

Fig. 1.10 Principle of MHD Power Generation

generated in the gas. Electrodes placed on the side of the duct pick-up potential generated in the gas. The direct current thus obtained can be converted into AC using an inverter.

The system is simple with large power and temperature-handling capacity without any moving parts. It is highly reliable and can be brought to full load within 45 sec. Power output can be changed from no load to full load in fraction of a second.

11. Thermionic converter

Figure 1.11 shows a thermionic converter. It consists of two electrodes held in a container filled with ionized cesium vapour. Heating one electrode 'boils out' electrons that travel to the opposite colder side electrode. The positive ions in the gas neutralize the space-charge effect of the electrons that normally prevent the flow of electrons. Ionized gas offsets space-charge effect that tends to repel migration of electrons.

Electrons that are emitted by heating cathode are migrated to cooler anode collector and flow through outer circuit to develop electric power. Low-work function materials such as barium and strontium oxides are used for anodes, whereas high-work function materials such as Tungsten impregnated with barium is used for cathodes.

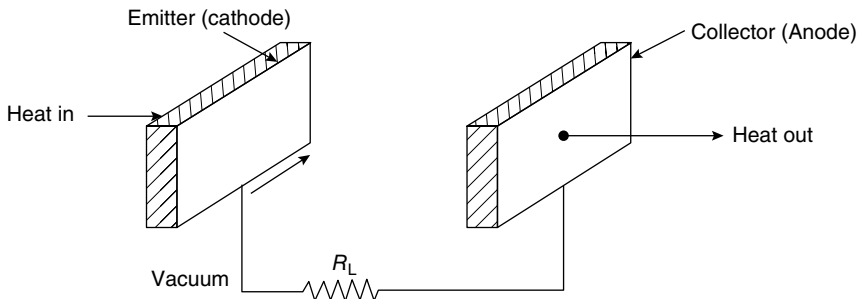

Fig. 1.11 Thermionic Converter

12. Thermoelectric power

It is a device that converts heat directly into electric power. It eliminates the conversion of heat into kinetic energy of gas or steam flow. Its principle is based on Seebeck effect: If two dissimilar materials are joined to form a loop and the two junctions are maintained at different temperatures, an emf will be developed around the loop. The magnitude of the emf (E) developed by the above process is proportional to the temperature difference between the two junctions. Figure 1.12 shows a thermoelectric generator.

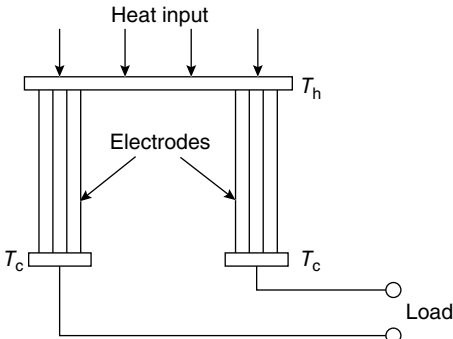

Fig. 1.12 Thermoelectric Generator

$$E \propto (T_2 - T_1) = \alpha (T_h - T_c)$$

where T_h = Temperature of hot junction; T_c = Temperature of cold junction; α = Seebeck coefficient.

The hot junction is maintained at a temperature T_h by the applied heat source that may be small oil or gas burner, a nuclear reactor, or

direct solar radiation by paraboloidal concentrator, and the cold junction is maintained at T_c by either water cooling or radiative heat transfer.

The amount of power generated in a country depends on the utilization of natural resources available in that country apart from its geographical location. Total power generated is usually contributed by power generated by hydel plant, thermal power plant and nuclear power plant. The amount of power available by a hydel plant entirely depends on natural sites available and on the hydrological cycle in the area concerned. Since the amount of the rainfall varies considerably over years, it is difficult to run a hydel plant without sufficient water source. Thus for variable load conditions, a hydraulic power plant is not reliable. This difficulty is overcome by installing a thermal power plant. The advantage of steam power plant is that human beings can create the site near a water resource and fuel resource. The steam power plant can be used as a base load plant along with a hydel or nuclear power plant.

2.2. CLASSIFICATION OF STEAM POWER PLANTS

The steam power plants may be *classified* as follows :

1. Central stations.
2. Industrial power stations or captive power stations.

1. **Central stations.** The electrical energy available from these stations is meant for general sale to the customers who wish to purchase it. Generally, these stations are *condensing type* where the exhaust steam is discharged into a condenser instead of into the atmosphere. In the condenser the pressure is maintained below the atmospheric pressure and the exhaust steam is condensed.

2. **Industrial power stations or captive power stations.** This type of power station is run by a manufacturing company for its own use and its output is not available for general sale. Normally these plants are *non-condensing* because a large quantity of steam (low pressure) is required for different manufacturing operations.

1

Thermal Power Plants

1.1 INTRODUCTION—POWER PLANT ENGINEERING

In the modern scenario, the need for electricity is increasing very rapidly. Electric power is considered as the heart of any industry. Electricity is used in our day-to-day life for lighting, heating, lifting, and cooking and so on. Therefore, it is necessary to produce electricity in large scale and also economically. The large scale power production could be achieved only by means of suitable power producing units like power plants. The most commonly used power plants are steam/thermal, Gas, Diesel, Hydroelectric and nuclear power plants. The main aspects consider while constructing or designing a power plant is the selection of proper location and appropriate equipments for the plant such that maximum output is achieved. The generated power must also be cost effective, reliable and fairly uninterrupted.

1.2 CLASSIFICATION OF POWER PLANTS

Bulk electric power is generated by special plants known as generating stations or power plants. A generating station consists of a prime mover coupled to an alternator to produce electric power.

The prime mover converts different energy forms like kinetic energy, potential energy, chemical energy, into mechanical energy. The alternator converts the mechanical energy to electrical energy.

Depending upon the energies or input converted by prime mover into mechanical energy, the power plants are classified as follows:

1. Steam power plants
2. Hydroelectric power plants
3. Diesel power plants
4. Nuclear power plants.

1.1 STEAM POWER PLANTS:

A thermal power station is a power plant in which the prime mover is steam driven. Water is heated, turns into steam and spins a steam turbine which drives an electrical generator. After it passes through the turbine, the steam is condensed in a condenser and recycled to where it was heated; this is known as a **Rankine cycle**. The greatest variation in the design of thermal power stations is due to the different fuel sources. Some prefer to use the term *energy center* because such facilities convert forms of heat energy into electricity. Some thermal power plants also deliver heat energy for industrial purposes, for district heating, or for desalination of water as well as delivering electrical power. A large proportion of CO₂ is produced by the world's fossil fired thermal power plants; efforts to reduce these outputs are various and widespread.

LAYOUT OF STEAM POWER PLANT:

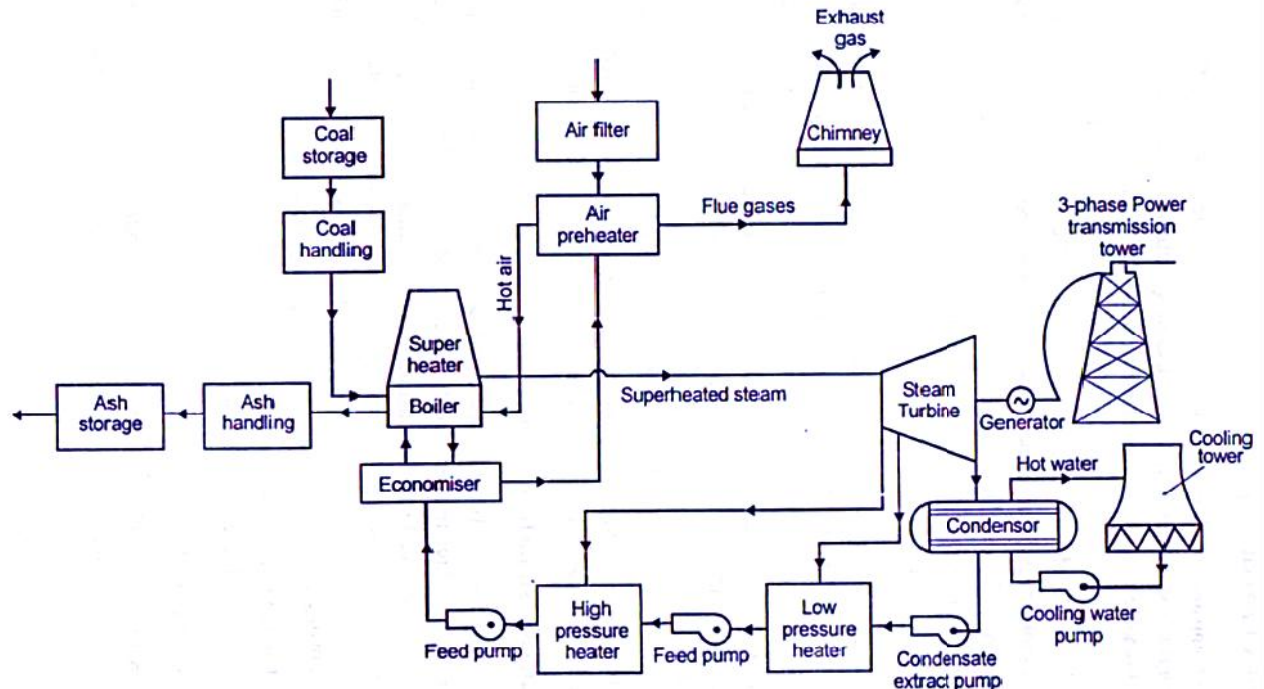

The four main circuits one would come across in any thermal power plant layout are

- Coal and Ash Circuit
- Air and Gas Circuit
- Feed Water and Steam Circuit
- Cooling Water Circuit

Coal and Ash Circuit

Coal and Ash circuit in a thermal power plant layout mainly takes care of feeding the boiler with coal from the storage for combustion. The ash that is generated during combustion is collected at the back of the boiler and removed to the ash storage by scrap conveyors. The combustion in the Coal and Ash circuit is controlled by regulating the speed and the quality of coal entering the grate and the damper openings.

Air and Gas Circuit

Air from the atmosphere is directed into the furnace through the air preheated by the action of a forced draught fan or induced draught fan. The dust from the air is removed before it enters the combustion chamber of the thermal power plant layout. The exhaust gases from the combustion heat the air, which goes through a heat exchanger and is finally let off into the environment.

Feed Water and Steam Circuit

The steam produced in the boiler is supplied to the turbines to generate power. The steam that is expelled by the prime mover in the thermal power plant layout is then condensed in a condenser for re-use in the boiler. The condensed water is forced through a pump into the feed water heaters where it is heated using the steam from different points in the turbine. To make up for the lost steam and water while passing through the various components of the thermal power plant layout, feed water is supplied through external sources. Feed water is purified in a purifying plant to reduce the dissolve salts that could scale the boiler tubes.

Cooling Water Circuit

The quantity of cooling water required to cool the steam in a thermal power plant layout is significantly high and hence it is supplied from a natural water source like a lake or a river. After passing through screens that remove particles that can plug the condenser tubes in a thermal power plant layout, it is passed through the condenser where the steam is condensed. The water is finally discharged back into the water source after cooling. Cooling water circuit can also be a closed system where the cooled water is sent through cooling towers for re-use in the power plant. The cooling water circulation in the condenser of a thermal power plant layout helps in maintaining a low pressure in the condenser all throughout.

All these circuits are integrated to form a thermal power plant layout that generates electricity to meet our needs.

Advantages

- Generation of power is continuous.
- Initial cost low compared to hydel plant.
- Less space required.
- This can be located near the load centre so that the transmission losses are reduced.
- It can respond to rapidly changing loads.

Disadvantages

- Long time required for installation.
- Transportation and handling of fuels major difficulty.
- Efficiency of plant is less.
- Power generation cost is high compared to hydel power plant.
- Maintenance cost is high.

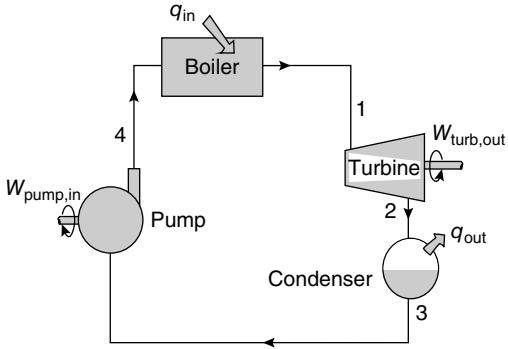

Fig. 4.5 Rankine Cycle

4.3.2 Rankine Cycle

Figure 4.5 shows a Rankine cycle, which forms the basic working cycle of steam power plants. In this cycle, feed water supplied by a multistage feed pump is raised into steam in a boiler. The high-pressure steam is expanded in the turbine, generating work. After expansion, the steam is condensed in a condenser and the cycle repeats. In a real cycle, due to irreversibility, losses are present and the cycle efficiency decreases.

Figure 4.6 shows a simple Rankine cycle on $p-V$ and $T-s$ diagrams. In this cycle, either saturated steam enters the turbine at point 1 or superheated steam enters the turbine at point 1'. Cycle 1-2-3-4-b-1 is a saturated Rankine cycle and cycle 1'-2'-3-4-b-1' is a superheated Rankine cycle.

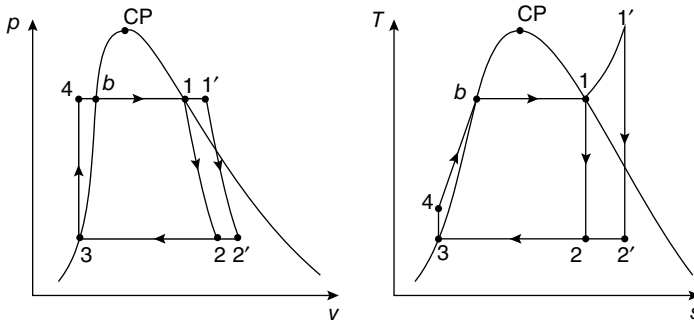

Fig. 4.6 Rankine Cycle on $p-V$ and $T-s$ Diagrams

The cycle has the following reversible processes:

- (i) **1-2 or 1'-2'**: Adiabatic reversible expansion through the turbine. The exhaust vapour at the end of expansion at 2 or 2' is usually in the two-phase region.
- (ii) **2-3 or 2'-3**: A two-phase mixture constant temperature and pressure process. Heat is rejected in the condenser at constant pressure.
- (iii) **3-4**: Adiabatic reversible compression. The pump increases saturated liquid at condenser pressure at 3, to subcooled liquid at the steam generator pressure, 4. Line 3-4 is a vertical line as the liquid is incompressible and pump work is adiabatic reversible.
- (iv) **4-1 or 4-1'**: Heat is added at constant pressure in the steam generator. It is shown by the line 4-b-1-1'. During the process 4-b, subcooled liquid at point 4 becomes

saturated at point b . This conversion occurs in the economizer of the steam generator. During the process $b-1$, saturated liquid at point b is heated at constant pressure and temperature to saturated vapour at point 1. This change occurs in the evaporator or boiler. Process $1-1'$ corresponds to the conversion of saturated vapour at point 1 to superheated vapour at point $1'$ in the super heater.

Let h_1 = enthalpy of saturated vapour at 1
 $h_{1'}$ = enthalpy of superheated vapour at $1'$
 h_2 = enthalpy of steam vapour at 2
 $h_{2'}$ = enthalpy of steam vapour at $2'$
 $h_3 = h_{f3}$ = enthalpy of water at point 3
 $h_4 = h_{f4}$ = enthalpy of water at point 4
 $h_b = h_{fb}$ = enthalpy of water at point b

(v) Heat added per unit mass at constant pressure process $4-b-1$ or $4-b-1'$ is given by

$$q_A = h_1 - h_{f4} \text{ kJ/kg saturated vapour cycle}$$

$$q_A = h_{1'} - h_{f4} \text{ kJ/kg superheated vapour cycle}$$

(vi) Heat rejected at constant pressure process $2-3$ or $2'-3$ is

$$q_R = h_2 - h_{f3} \text{ kJ/kg saturated vapour cycle}$$

$$q_R = h_{2'} - h_{f3} \text{ kJ/kg superheated vapour cycle}$$

(vii) Turbine work during the process $1-2$ or $1'-2$ is

$$w_T = h_1 - h_2 \text{ kJ/kg saturated vapour cycle}$$

$$w_T = h_{1'} - h_2 \text{ kJ/kg superheated vapour cycle}$$

(viii) Pump work during the process $3-4$ is

$$w_p = h_{f4} - h_{f3} \text{ kJ/kg}$$

$$= v_3 (p_4 - p_3) \text{ kJ/kg}$$

1. Net work done

Net work for saturated vapour cycle

$$= \text{Heat added} - \text{Heat rejected}$$

$$= (h_1 - h_{f4}) - (h_2 - h_{f3})$$

$$= (h_1 - h_2) - (h_{f4} - h_{f3}) \text{ kJ/kg}$$

$$= (h_1 - h_2) - w_p$$

Net work for superheated vapour cycle

$$= \text{Heat added} - \text{Heat rejected}$$

$$= (h_{1'} - h_{f4}) - (h_{2'} - h_{f3})$$

$$= (h_{1'} - h_{2'}) - (h_{f4} - h_{f3}) \text{ kJ/kg}$$

$$= (h_{1'} - h_{2'}) - w_p$$

2. Thermal efficiency

Thermal efficiency is given by

$$= \frac{q_w}{q_A}$$

Thermal efficiency for saturated vapour cycle

$$= \frac{(h_1 - h_2) - w_p}{(h_1 - h_{f4})}$$

Thermal efficiency for superheated vapour cycle

$$= \frac{(h_{1'} - h_{2'}) - w_p}{(h_{1'} - h_{f4})}$$

4.3.2.1 Actual and Ideal Processes for a Rankine Cycle

As mentioned earlier, in an actual Rankine cycle, due to the irreversibilities in various components arising out of fluid friction and heat loss to the surroundings, pressure drop in the boiler, condenser and piping system is inevitable. To overcome the pressure drop, it is essential to supply feed water to the system at sufficiently higher pressure than the ideal cycle. This results in higher power consumption. Both ideal and actual cycles are shown in Figure 4.7(a) and (b).

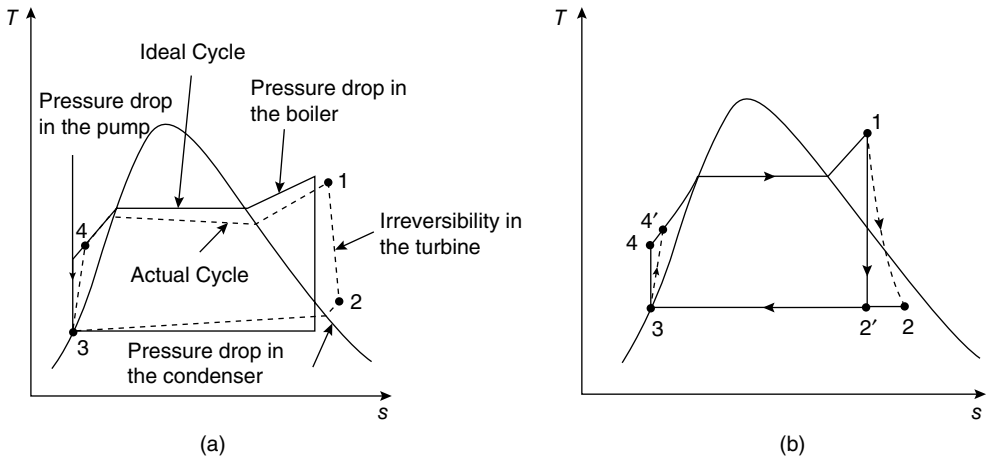

Fig. 4.7 Actual and Ideal Processes for a Rankine Cycle

Due to the heat loss to the surroundings, turbine work decreases resulting in lower efficiency, given by the following equations. Pump efficiency for an actual cycle is given by

$$\eta_p = \frac{q_w}{q_A} = \frac{h_{4'} - h_1}{h_4 - h_1}$$

Turbine efficiency for an actual cycle is give by

$$\eta_T = \frac{q_A}{q_w} = \frac{h_1 - h_2}{h_1 - h_{2'}}$$

The *work ratio* is defined as the ratio of net work output to positive work output.

$$i. e., \quad work\ ratio = \frac{W_{net}}{W_T} = \frac{W_T - W_p}{W_T}$$

The capacity of a steam plant is often expressed in terms of steam rate, which is defined as the rate of steam flow (kg/h) required to produce unit shaft output (1 kW). It is also called as **specific steam consumption (S.S.C.)**.

Therefore,

$$\begin{aligned} SSC &= \frac{1}{W_{net}} = \frac{1}{W_T - W_p} \frac{\text{kg}}{\text{kJ}} \cdot \frac{1\text{kJ/s}}{1\text{kW}} \\ &= \frac{1}{W_T - W_p} \frac{\text{kg}}{\text{kWs}} = \frac{3600}{W_T - W_p} \frac{\text{kJ}}{\text{kWh}} \end{aligned}$$

Example 4.1

A simple Rankine cycle works between the boiler pressure of 3 MPa and condenser pressure of 4 kPa. The steam is dry saturated before the throttling in the turbine. Determine

- (i) Rankine cycle efficiency
- (ii) work ratio
- (iii) specific steam consumption

Solution: From the steam tables at 3 MPa (30 bar) and saturated vapour condition

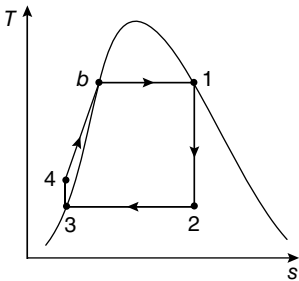

$$h_1 = 2802.3 \text{ kJ/kg}$$

$$h_2 = h_{f2} + x h_{fg2}$$

$$= 121.4 + x_2 \times 2433.1$$

But, process 1-2 is isentropic,

$$\therefore s_1 = 6.1838 = s_2 = (s_{f2} + x_2 s_{fg2})_{4 \text{ kPa}}$$

$$\text{i.e. } 6.1838 = 0.4225 + x_2 \times 8.0530$$

$$x_2 = 0.7154$$

$$\text{Hence, } h_2 = 121.4 + 0.7154 \times 2433.1$$

$$= 1862.04 \text{ kJ/kg}$$

- (i) Rankine cycle efficiency,

$$\text{Pump work} = v_3 (p_4 - p_3)$$

$$w_p = 0.001 (30 - 0.04)100$$

$$= 3 \text{ kJ/kg}$$

$$h_{f4} = h_{f3} + w_p$$

$$= 121.4 + 3$$

$$\begin{aligned}
 &= 124.4 \text{ kJ/kg} \\
 \eta &= \frac{(h_1 - h_2) - w_p}{(h_1 - h_{f4})} \\
 &= \frac{(2802.3 - 1862.04) - 3}{(2802.3 - 124.4)} \\
 &= \frac{937.26}{2677.9} \\
 &= 0.35 = 35\%
 \end{aligned}$$

(ii) Work ratio

$$\begin{aligned}
 W_R &= \frac{(h_1 - h_2) - w_p}{(h_1 - h_2)} \\
 &= \frac{(2802.3 - 1862.04) - 3}{(2802.3 - 1862.04)} \\
 &= \frac{937.26}{940.26} = 0.997
 \end{aligned}$$

(iii) Specific steam consumption

$$\begin{aligned}
 m &= \frac{1}{\text{Turbine work}} \\
 &= \frac{1}{(h_1 - h_2)} = \frac{1 \times 3600}{(2802.3 - 1862.04)} \\
 &= \frac{3600}{940.26} \\
 &= 3.83 \text{ kg/kWh}
 \end{aligned}$$

Example 4.2

In a steam power plant operating on ideal Rankine cycle, steam enters the turbine at 20 bar with an enthalpy of 3248 kJ/kg and an entropy of 7.127 kJ/kg K. The condenser pressure is 0.1 bar. Find the cycle efficiency and specific steam consumption in kg/kWh. Do not neglect pump work. You may make use of the extract of steam table given below.

p (bar)	t (°C)	h _f kJ/kg	h _g kJ/kg	s _f kJ/kg	s _g kJ/kg
20.0	212.4	908.8	1890.7	2.447	6.331
0.1	45.81	191.83	2584.7	0.6493	8.1502

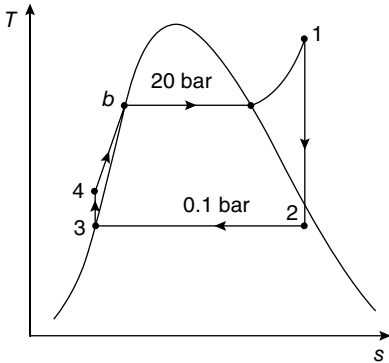

Solution:

At 20 bar,

$$h_1 = 3248 \text{ kJ/kg}$$

$$s_1 = 7.127 \text{ kJ/kg K}$$

As process 1–2 is isentropic,

$$s_1 = s_2$$

$$= s_{f2} + x_2 \times s_{fg2}$$

$$\text{i.e. } 7.127 = 0.6493 + x_2 \times (8.1502 - 0.6493)$$

$$\therefore x_2 = 0.864$$

At 0.1 bar,

$$h_2 = h_{f2} + x_2 h_{fg2}$$

$$= 191.83 + 0.864 \times (2584.7 - 191.83)$$

$$= 191.83 + 0.864 \times 2392.87$$

$$= 2259.27 \text{ kJ/kg}$$

Pump work,

$$W_p = v_3 (p_4 - p_3)$$

But,

$$v_3 = v_f = 0.001 \text{ m}^3/\text{kg} \text{ at } 0.1 \text{ bar from steam tables}^*$$

$$\therefore W_p = 0.001 (20 - 0.1)100$$

$$= 1.99 \text{ kJ/kg}$$

Now,

$$W_p = h_{f4} - h_{f3}$$

$$\therefore h_{f4} = W_p + h_{f3} \text{ at } 0.1 \text{ bar}$$

$$= 1.99 + 191.83$$

$$= 193.82 \text{ kJ/kg}$$

Rankine cycle efficiency

$$\eta = \frac{(h_1 - h_2) - w_p}{(h_1 - h_{f4})}$$

$$= \frac{(3248 - 2259.27) - 1.99}{(3248 - 193.82)}$$

$$= \frac{986.74}{3054.18}$$

$$= 32.31\%$$

Specific steam consumption

$$m = \frac{3600}{\text{Turbine work}}$$

$$= \frac{1 \times 3600}{(h_1 - h_2)} = \frac{3600}{3248 - 2259.27}$$

$$= 3.64 \text{ kg/kWh}$$

Example 4.3

A steam turbine receives steam at 15 bar and 300°C and leaves the turbine at 0.1 bar and 4% moisture. Determine

- (i) Rankine efficiency
- (ii) steam consumption per kW per hour if the efficiency ratio is 0.70
- (iii) Carnot cycle efficiency for the given temperature limits
- (iv) change in Rankine efficiency and specific consumption if the condenser pressure is reduced to 0.04 bar

Solution:

From the steam tables,
at 15 bar 300°C,

$$h_1 = 3038.9 \text{ kJ/kg}$$

$$s_1 = 6.9207 \text{ kJ/kg}$$

At 0.1 bar and 4% dry,

$$h_2 = h_{f2} + x_2 h_{fg2}$$

$$= 191.8 + 2392.9 \times 0.96$$

$$= 2488.98 \text{ kJ/kg}$$

At 0.04 bar

$$s_1 = s_2' = s_{f2'} + x_2' \cdot s_{fg2'}$$

$$6.9207 = 0.4225 + x_2' \times 8.0530$$

$$x_2' = 0.81$$

Hence,

$$h_2' = h_{f2'} + x_2' h_{fg2'}$$

$$= 121.4 + 0.81 \times 2433.1$$

$$= 2092.21 \text{ kJ/kg}$$

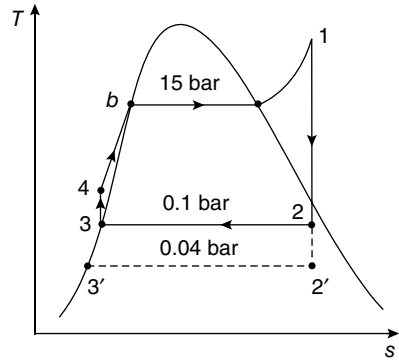

- (i) Rankine efficiency

$$\text{pump work} = W_p = v_3 (p_4 - p_3)$$

$$\text{but, } v_3 = v_f \text{ at } 0.1 \text{ bar}$$

$$= 0.001 \text{ m}^3/\text{kg}$$

$$\therefore W_p = 0.001 \times (15 - 0.1) \times 100$$

$$= 1.49 \text{ kJ/kg}$$

Again,

$$W_p = h_{f4} - h_{f3}$$

$$h_{f4} = 1.49 + 191.8$$

$$= 193.29 \text{ kJ/kg}$$

Hence, Rankine efficiency

$$\begin{aligned}\eta &= \frac{(h_1 - h_2) - w_p}{(h_1 - h_{f4})} \\ &= \frac{(3038.9 - 2488.98) - 1.49}{(3038.9 - 193.29)} \\ &= \frac{548.43}{2845.6} = 0.193 \\ &= 19.30\%\end{aligned}$$

(ii) Specific fuel consumption

$$\text{Now, efficiency ratio} = \frac{\text{Indicated thermal efficiency}}{\text{Rankine efficiency}}$$

$$\text{Indicated thermal efficiency} = 0.7 \times 0.193 = 0.135$$

But, indicated thermal efficiency,

$$\begin{aligned}0.135 &= \frac{3600}{\text{Turbine work}} \\ &= \frac{1 \times 3600}{m(h_1 - h_2)}\end{aligned}$$

\therefore specific fuel consumption

$$\begin{aligned}m &= \frac{3600}{0.135(3038.9 - 2488.98)} \\ &= 48.49 \text{ kg/kWh}\end{aligned}$$

(iii) Carnot efficiency

$$\eta = \frac{T_{\max} - T_{\min}}{T_{\max}}$$

$$\text{but, } T_{\max} = 300^\circ\text{C}$$

$$T_{\min} = 45.83^\circ\text{C at 0.1 bar}$$

$$\text{Hence, } \eta = \frac{300 - 45.83}{300 + 273} = 0.4436$$

$$= 44.36\%$$

(iv) Change in Rankine efficiency and specific fuel consumption at 0.04 bar condenser pressure

At 0.04 bar, condenser pressure

$$V_{3'} = V_{f3'} = 0.001 \text{ m}^3/\text{kg}$$

Example 12.2 Steam at 20 bar, 360°C is expanded in a steam turbine to 0.08 bar. It then enters a condenser, where it is condensed to saturated liquid water. The pump feeds back the water into the boiler. (a) Assuming ideal processes, find per kg of steam the net work and the cycle efficiency. (b) If the turbine and the pump have each 80% efficiency, find the percentage reduction in the net work and cycle efficiency.

Solution The property values at different state points (Fig. Ex. 12.2) found from the steam tables are given below.

$$h_1 = 3159.3 \text{ kJ/kg} \quad s_1 = 6.9917 \text{ kJ/kg K}$$

$$h_3 = h_{fp2} = 173.88 \text{ kJ/kg} \quad s_3 = s_{fp2} = 0.5926 \text{ kJ/kg K}$$

$$h_{fgp2} = 2403.1 \text{ kJ/kg} \quad s_{gp2} = 8.2287 \text{ kJ/kg K}$$

$$v_{fp2} = 0.001008 \text{ m}^3/\text{kg} \quad \therefore s_{fgp2} = 7.6361 \text{ kJ/kg K}$$

Now

$$s_1 = s_{2s} = 6.9917 = s_{fp2} + x_{2s} s_{fgp2} = 0.5926 + x_{2s} \cdot 7.6361$$

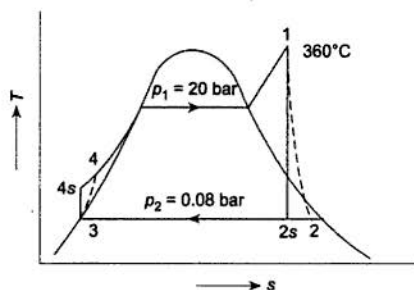

Fig. Ex. 12.2

$$\therefore x_{2s} = \frac{6.3991}{7.6361} = 0.838$$

$$\therefore h_{2s} = h_{fp2} + x_{2s} h_{fgp2} = 173.88 + 0.838 \times 2403.1 = 2187.68 \text{ kJ/kg}$$

$$(a) \quad W_p = h_{4s} - h_3 = v_{fp2} (p_1 - p_2) = 0.001008 \frac{\text{m}^3}{\text{kg}} \times 19.92 \times 100 \frac{\text{kN}}{\text{m}^2} = 2.008 \text{ kJ/kg}$$

$$h_{4s} = 175.89 \text{ kJ/kg}$$

$$W_T = h_1 - h_{2s} = 3159.3 - 2187.68 = 971.62 \text{ kJ/kg}$$

$$\therefore W_{\text{net}} = W_T - W_p = 969.61 \text{ kJ/kg}$$

$$Q_1 = h_1 - h_{4s} = 3159.3 - 175.89$$

$$= 2983.41 \text{ kJ/kg} \quad \text{Ans.}$$

$$\therefore \eta_{\text{cycle}} = \frac{W_{\text{net}}}{Q_1} = \frac{969.61}{2983.41} = 0.325, \text{ or } 32.5\%$$

$$(b) \text{ If } \eta_p = 80\%, \text{ and } \eta_T = 80\% \quad \text{Ans.}$$

$$W_p = \frac{2.008}{0.8} = 2.51 \text{ kJ/kg}$$

$$W_T = 0.8 \times 971.62 = 777.3 \text{ kJ/kg}$$

$$\therefore W_{\text{net}} = W_T - W_p = 774.8 \text{ kJ/kg}$$

\therefore % Reduction in work output

$$= \frac{969.61 - 774.8}{969.61} \times 100 = 20.1\% \quad \text{Ans.}$$

$$h_{4s} = 173.88 + 2.51 = 176.39 \text{ kJ/kg}$$

$$\therefore Q_1 = 3159.3 - 176.39 = 2982.91 \text{ kJ/kg}$$

$$\therefore \eta_{\text{cycle}} = \frac{774.8}{2982.91} = 0.2597, \text{ or } 25.97\%$$

∴ % Reduction in cycle efficiency

$$= \frac{0.325 - 0.2597}{0.325} \times 100 = 20.1\%$$

Ans.

Example 12.3 A cyclic steam power plant is to be designed for a steam temperature at turbine inlet of 360°C and an exhaust pressure of 0.08 bar. After isentropic expansion of steam in the turbine, the moisture content at the turbine exhaust is not to exceed 15%. Determine the greatest allowable steam pressure at the turbine inlet, and calculate the Rankine cycle efficiency for these steam conditions. Estimate also the mean temperature of heat addition.

Solution As state 2s (Fig. Ex. 12.3), the quality and pressure are known.

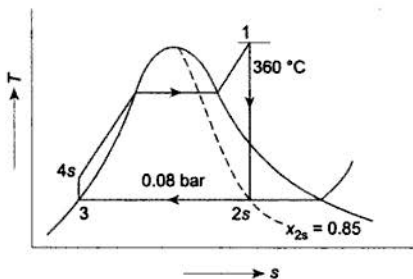

Fig. Ex. 12.3

$$\therefore s_{2s} = s_f + x_{2s} s_{fg} = 0.5926 + 0.85 (8.2287 - 0.5926) = 7.0833 \text{ kJ/kg K}$$

Since

$$s_1 = s_{2s}$$

$$\therefore s_1 = 7.0833 \text{ kJ/kg K}$$

At state 1, the temperature and entropy are thus known. At 360°C, $s_g = 5.0526$ kJ/kg K, which is less than s_1 . So from the table of superheated steam, at $t_1 = 360^\circ\text{C}$ and $s_1 = 7.0833$ kJ/kg K, the pressure is found to be 16.832 bar (by interpolation).

∴ The greatest allowable steam pressure is

$$p_1 = 16.832 \text{ bar}$$

Ans.

$$h_1 = 3165.54 \text{ kJ/kg}$$

$$h_{2s} = 173.88 + 0.85 \times 2403.1 = 2216.52 \text{ kJ/kg}$$

$$h_3 = 173.88 \text{ kJ/kg}$$

$$h_{4s} - h_3 = 0.001 \times (16.83 - 0.08) \times 100 = 1.675 \text{ kJ/kg}$$

$$\therefore h_{4s} = 175.56 \text{ kJ/kg}$$

$$Q_1 = h_1 - h_{4s} = 3165.54 - 175.56$$

$$= 2990 \text{ kJ/kg}$$

$$W_T = h_1 - h_{2s} = 3165.54 - 2216.52 = 949 \text{ kJ/kg}$$

$$W_P = 1.675 \text{ kJ/kg}$$

$$\eta_{\text{cycle}} = \frac{W_{\text{net}}}{Q_1} = \frac{247.32}{2990} = 0.3168 \text{ or } 31.68\% \quad \text{Ans.}$$

Mean temperature of heat addition

$$T_{\text{ml}} = \frac{h_1 - h_{4s}}{s_1 - s_{4s}} = \frac{2990}{7.0833 - 0.5926} \\ = 460.66 \text{ K} = 187.51^\circ\text{C}.$$

Example 12.4 A steam power station uses the following cycle:

Steam at boiler outlet—150 bar, 550°C

Reheat at 40 bar to 550°C

Condenser at 0.1 bar.

Using the Mollier chart and assuming ideal processes, find the (a) quality at turbine exhaust, (b) cycle efficiency, and (c) steam rate.

Solution The property values at different states (Fig. Ex. 12.4) are read from the Mollier chart.

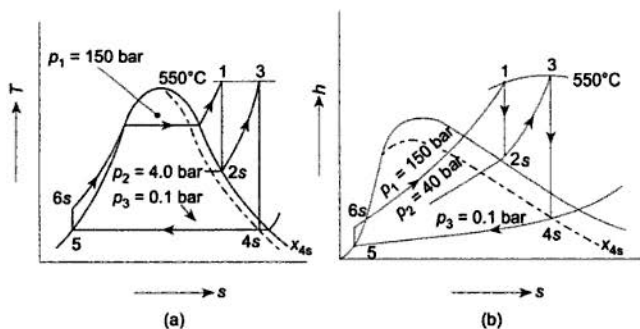

Fig. Ex. 12.4

$$h_1 = 3465, h_{2s} = 3065, h_3 = 3565,$$

$$h_{4s} = 2300 \text{ kJ/kg } x_{4s} = 0.88, h_5 (\text{steam table}) = 191.83 \text{ kJ/kg}$$

Quality at turbine exhaust = 0.88

Ans. (a)

$$W_P = v \Delta p = 10^{-3} \times 150 \times 10^2 = 15 \text{ kJ/kg}$$

$$h_{6s} = 206.83 \text{ kJ/kg}$$

$$Q_1 = (h_1 - h_{6s}) + (h_3 - h_{2s}) \\ = (3465 - 206.83) + (3565 - 3065) = 3758.17 \text{ kJ/kg}$$

$$W_T = (h_1 - h_{2s}) + (h_3 - h_{4s}) \\ = (3465 - 3065) + (3565 - 2300) = 1665 \text{ kJ/kg}$$

4.3.4 Reheat Cycle

As evident from our earlier discussion, efficiency of the simple Rankine cycle increases by increasing the pressure and the temperature of steam entering the turbine. If the steam pressure is increased at the turbine inlet, expansion ratio of the turbine also increases and hence steam becomes very wet at the end of expansion. This has an ill effect of erosion and corrosion of turbine blades, maximizing the losses, resulting in drop in efficiency of nozzle and blades. This difficulty is overcome by extracting steam at a suitable point in the turbine and reheating it again by some means.

A schematic diagram of a reheat cycle is shown in Figure 4.17.

In this cycle, the steam at point 1 is expanded in the turbine and a part of the steam is extracted at point 2 and returned back to the steam generator. Hence, the extracted steam is again heated at constant pressure (ideal case) to a temperature at 3, but nearer to temperature at 1. The reheated steam expands in the LPT to the condenser pressure.

Solution: From the steam tables,
At 2 MPa and 500°C

$$h_3 = 3467.3 \text{ kJ/kg}$$

At 8 kPa,

$$h_{f5} = 173.9 \text{ kJ/kg}$$

Thermal efficiency of the turbine,

Now,

$$h_1 - h_2 = 650 \text{ kJ/kg}$$

$$h_3 - h_4 = 760 \text{ kJ/kg}$$

Net work done by the turbine

$$\begin{aligned} W_T &= (h_1 - h_2) + (h_3 - h_4) \\ &= 650 + 760 = 1410 \text{ kJ/kg} \end{aligned}$$

Heat supplied during the process,

$$\begin{aligned} q_A &= (h_1 - h_{f5}) + (h_3 - h_2) \\ &= (h_1 - h_2) + (h_3 - h_{f5}) \\ &= 650 + (3467.3 - 173.9) \\ &= 3943.4 \text{ kJ/kg} \end{aligned}$$

$$\begin{aligned} \eta &= \frac{W_T}{q_A} = \frac{1410}{3943.4} = 0.3576 \\ &= 35.76\% \end{aligned}$$

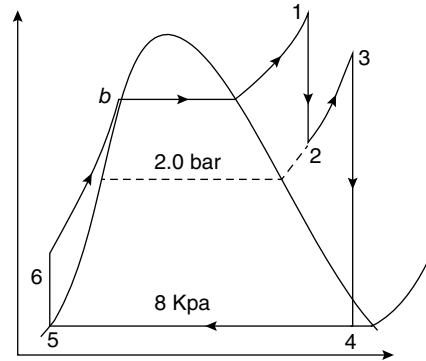

4.3.5 Regenerative Cycle

As it is known, reheating has limited ability to improve the thermodynamic efficiency of the cycle but is quite useful in the reduction of moisture in the turbine. However, it is observed that the largest single loss of energy in a power plant occurs at the condenser in which heat is rejected to the coolant. Hence, reducing this rejected heat drastically improves cycle efficiency.

In both ideal Rankine and reheat cycles, the condensate is returned to the boiler at the lowest temperature of the cycle. The fluid is heated to saturation by direct mixing in the steam drum of the boiler, by furnace radiation in boiler tubes or by gas convection heating by the flue gases in the economizer. All these methods involve large temperature differences and are inherently irreversible. Instead of resorting to such procedure, a method of feed water heating is considered.

An ideal regenerative cycle is shown in Figure 4.19. The steam expands in a reversible manner such that area under the curve 2-3 (2-3-4-B-2) would be exactly

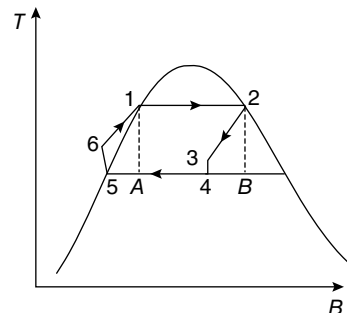

Fig. 4.19 Ideal Regenerative T-s Diagram

equal to the area under the curve 6-1 (6-1-A-5-6). That means the increase in entropy during heating equals to the decrease during the expansion and cooling of vapour. Thus, the cycle is equivalent to a Carnot cycle operating between maximum and minimum temperatures.

In practice, the ideal cycle is approached by allowing the condensate from the feed pump to be heated in a separate heater or heaters by steam extracted from the turbine after it was partly expanded and work done. The extracted steam either mixes directly with the condensate, as in an open heater, or exchanges heat indirectly and condense as in a closed heater. The schematic of an ideal regenerative cycle power plant is shown in Figure 4.20.

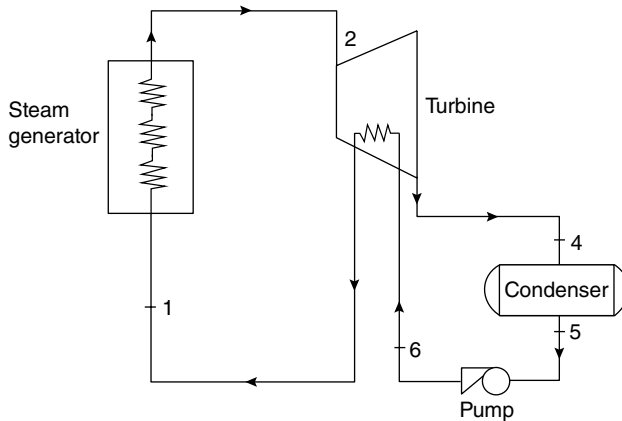

Fig. 4.20 Ideal Regenerative Cycle Power Plant

An infinite number of heat exchangers, known as feed water heaters, are essential in order to carryout ideal regeneration process. These feed water heaters are used to preheat the condensate with steam extracted from the steam turbine. This is practically not feasible. In addition, the thermal efficiency gain due to the addition of heaters drops as the number of heaters increases. A point is reached so that further addition of heaters is no longer economically justified due to the increased capital cost. In practice, maximum six to seven heaters are employed in very large power plants (refer Figure 4.21).

Work done by the turbine during process 3-4, 4-5, 5-6 and 6-7

$$w_T = (h_3 - h_4) + (1 - m_1) (h_4 - h_5) + (1 - m_1 - m_2) (h_5 - h_6) + (1 - m_1 - m_2 - m_3) (h_6 - h_7)$$

1. Net work done by the cycle

$$= \text{Heat added} - \text{Heat rejected} = q_A - q_R$$

$$= (h_3 - h_{f1}) - (1 - m_1 - m_2 - m_3) (h_7 - h_8)$$

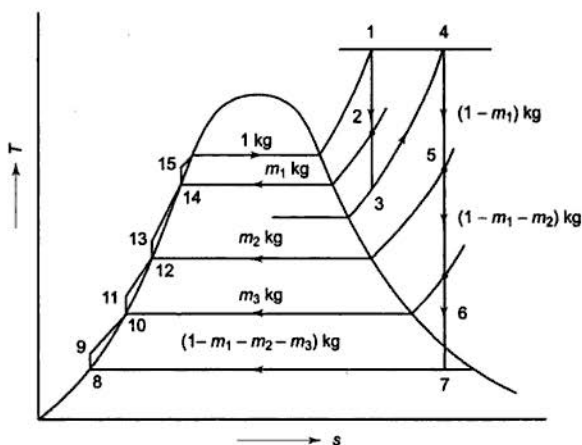

Fig. 12.23 *T-s diagram of reheat-regenerative cycle*

$$Q_1 = (h_1 - h_{15}) + (1 - m_1)(h_4 - h_3) \text{ kJ/kg}$$

and

$$Q_2 = (1 - m_1 - m_2 - m_3)(h_7 - h_8) \text{ kJ/kg}$$

The energy balances of heaters 1, 2, and 3 give

$$m_1 h_2 + (1 - m_1) h_{13} = 1 \times h_{14}$$

$$m_2 h_5 + (1 - m_1 - m_2) h_{11} = (1 - m_1) h_{12}$$

$$m_3 h_6 + (1 - m_1 - m_2 - m_3) h_9 = (1 - m_1 - m_2) h_{10}$$

from which m_1 , m_2 , and m_3 can be evaluated.

5.6 ACCESSORIES FOR THE STEAM GENERATOR

Boiler accessories are the appliances that ensure the improved efficiency of a boiler. Boiler accessories may be installed either inside or outside a boiler.

Most commonly used boiler accessories are the following:

1. Economizer
2. Superheater
3. Air preheater
4. Feed water pump
5. Pressure-reducing valve
6. Steam trap
7. Steam separator

The function of all the accessories is briefly discussed below.

1. *Economizer*

The function of the economizer is to recover a portion of heat of the exhaust gases before the flue gases enter the chimney and discharged to the atmosphere. The economizer is placed in the

path of the flue gases in between the boiler exit and entry to the chimney. Feed water coming from the feed pump when passed through the economizer tubes absorbs the heat in the exhaust gases. This increases the temperature of water entering the boiler. Due to the high temperature of feed water, fuel consumption reduces, and this increases the overall efficiency of the boiler.

2. *Superheater*

The function of the superheater is to increase the temperature of steam above its saturation temperature. As heat contained in unit mass of superheated steam is more than dry saturated or wet steam, it is used extensively in steam power plants. Steam from the boiler drum is passed through superheater tubes. Superheater tubes are placed in the furnace along the passage of flue gases. Temperature of steam is thus raised above the saturation temperature.

3. *Air preheater*

The function of the air heater is to recover the heat of a portion of exhaust flue gases before the flue gases enter the chimney. It is placed along the passage of the exhaust flue gases in between the economizer and the chimney.

Air from the forced draught fan is passed over the preheater tubes that contain flue gases. Temperature of air is increased, and this high-temperature air enters the furnace. Due to higher air temperature, combustion of the fuel becomes rapid and fuel consumption becomes less. This increases the overall efficiency of the boiler. Two types of air heaters are generally used.

(i) *Tubular or recuperative air preheater*

This type of air preheater is composed of steel tubes through which hot flue gases flow. Air is made to circulate over these steel tubes and thus gains heat.

(ii) *Regenerative air preheater*

This type of air preheater consists of a rotor that turns at about 2–3 rpm. The rotor is filled with thin corrugated metal elements. Hot gases pass through one-half of the heater and air through the other half. As the rotor turns, the heat storage elements transfer the heat absorbed from the hot gases to the incoming air.

4. *Feed water pump*

The function of the feed pump is to pump water at high pressure to the water space of the boiler drum. Many types of feed pumps are used.

(i) *Rotary pumps*

They are either driven by electric motors or small steam turbines. Water is pumped due to rotary action of the impeller.

(ii) *Reciprocating pumps*

They are continuously run by steam from the same boiler to which the water is fed. Water is pumped by reciprocating action.

5. *Pressure-reducing valve*

The function of the pressure-reducing valve is to maintain constant pressure on the delivery side of the valve with the fluctuating boiler pressure. Whenever the steam demand is fluctuating, it becomes very difficult to maintain uniform pressure. In such cases, a pressure-reducing valve is connected to the steam supply line.

6. Steam trap

The function of steam trap is to drain off water resulting from the partial condensation of steam in the steam pipe lines and jackets without allowing the steam to escape through it. Water collected in the steam pipe lines results in hammering, thereby damaging the pipelines and joints. Two types of steam traps are generally used: (i) bucket type or float type and (ii) thermal expansion type.

7. Steam separator

The function of the steam separator is to separate the water particles in suspension that are carried by the steam coming from the boiler. If suspended water particles enter the turbine or engine, they cause erosion and corrosion of blades and other parts. It is always installed as close to the engine or turbine as possible on the main pipeline.

v

3.12.2 Electrical Dust Collector (Electrostatic Precipitators)

With stringent air quality restriction by the governments, a majority of the power plants in the world use *electrostatic precipitators* (ESPs) for dust removal. An ESP can handle large volumes of flue gases accompanied low pressure drop and high collection efficiency (99.5 per cent). It facilitates easy removal of dust particles.

Figure 3.43 shows a general arrangement of an ESP. It consists of two sets of electrodes: the *emitting or discharging electrode* and *collecting electrode*. In the case of a *tubular-type* precipitator, emitting electrodes are placed in the centre of the pipe whereas in the case of *plate-type* precipitator, emitting electrodes are placed midway between the two plates. The emitting electrodes are connected to negative polarity of high-voltage (20–100 kV) DC source. The collecting electrodes are connected to the positive polarity of the source and earthed.

When high voltage is applied, it generates a unidirectional non-uniform electric field having greater magnitude at the discharge electrodes. This results in a blue luminous glow, called a *corona* around them. This corona is an indication of negatively charged ionized gas molecules that travel from discharge electrodes to grounded collection electrodes. The dust particles thus get deposited on the collector electrodes and lose their charge. The remaining dust particles cling to the electrode surface due to electrical resistivity, and are removed by rapping the electrodes using rapping motors.

Working principle

The principal components of ESPs are two sets of electrodes as shown in Figure 3.44. The first set comprises rows of electrically grounded vertical parallel plants, called collection

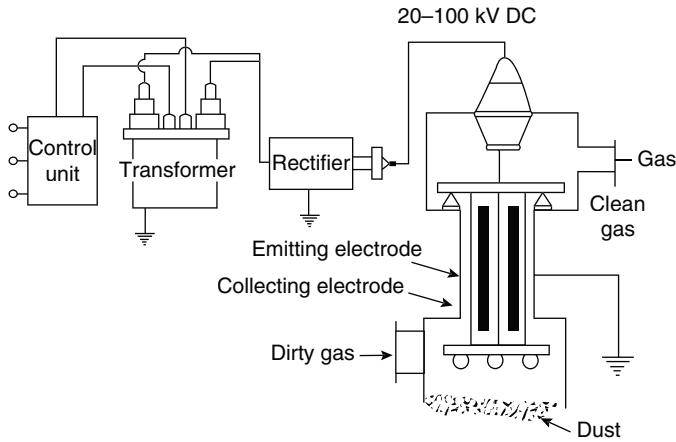

Fig. 3.43 A General Arrangement of an ESP

electrodes. The gas to be cleaned flows between these plates. The second set, called discharge electrodes, consist of wires. These are located centrally between each pair of parallel plates. The wires carry a unidirectional, negatively charged high-voltage (between 20 and 100 kV) current from an external source. This generates a non uniform, unidirectional electric field with greater magnitude near the discharge electrodes. When the voltage is high enough, a blue luminous glow, called corona, is produced around them. It is an indication of negatively charged gas ions. These ions travel from the wires to the grounded collection electrodes due to the presence of strong electric field between them.

Electrical forces in the corona accelerate the free electrons present in the gas, which in turn ionize the gas molecules, forming additional electrons and positive gas ions. The new electrons in turn again ionize the gas ions and this chain reaction continues.

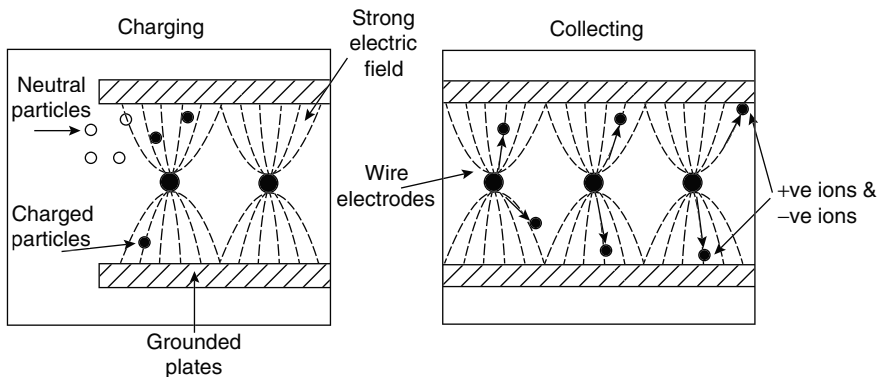

Fig. 3.44 Working Principle of ESP, Charging and Collecting

The +ve ions migrate to the negatively charged wire electrodes. The electrons follow the electric field towards the grounded electrodes. Their velocity decreases as they move away from corona region.

The -ve ions migrating along electric field lines collide with the particulate matter in the gas and charge them with negative potential. The particles after acquiring sufficient charge move towards the grounded electrodes.

Migration velocity is given by

$$V_m = \frac{2.95 \times 10^{-12} p(E/S)^2 d}{\mu_g}$$

where p = a function of particle dielectric constant

$$= 1.50 \rightarrow 2.40$$

E = applied voltage, V

S = distance between charging and collecting electrodes

d = particle diameter, m

μ_g = gas viscosity, kg/m s

When the particles collect on the grounded plates, they lose their charge to ground. The electrical resistivity causes only partial discharging. High resistivity results in holding of charges and increases the forces holding the particles to the plates low resistivity results in quick grounding of charges and hence re-entraining of particles.

When dust builds up on the plates, it deposits in a layer of increased thickness. This results in possible re-entry into the gas stream unless periodically removed. This is done by rapping the plates so as to cause shock vibrations that shake the dust into the hoppers at the bottom of the precipitator. The discharging and rapping processes are shown in Figure 3.45

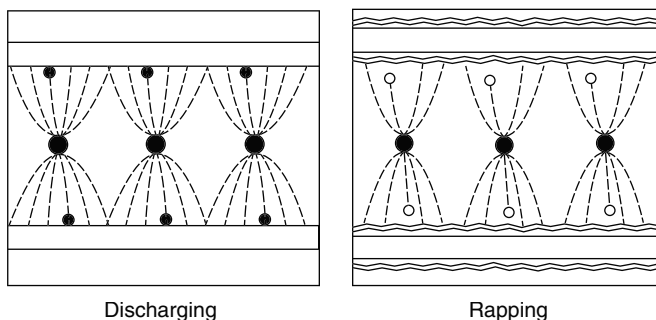
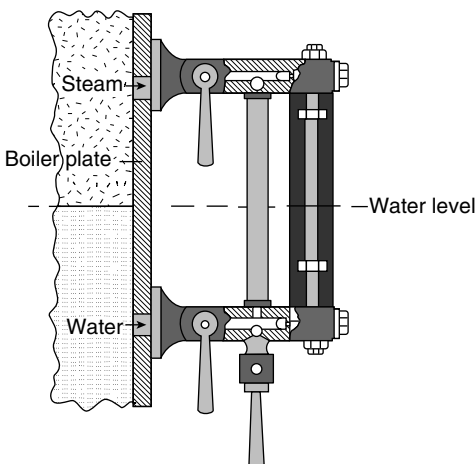

Fig. 3.45 Working Principle of ESP, Discharging and Rapping

5.7 BOILER MOUNTINGS

Boiler mountings are the external fittings that are required to ensure safe operation of the boiler.

These are necessary to regulate the steam flow, to measure certain parameters of water and steam, etc. The essential boiler mountings are as follows:



1. Water-level indicators (two numbers)
2. Pressure gauge
3. Steam stop valve or junction valve
4. Feed check valve
5. Blow-down valve or blow-off cock
6. Fusible plug
7. Safety valves (two numbers)

The function of all these mountings are described below.

5.7.1 Water-Level Indicator

The function of the water-level indicator is to indicate the level of water inside the boiler drum at any given instant. Two water-level

Fig. 5.32 *Water-Level Indicator*

indicators (one serves as a standby) are fitted at the front of the boiler drum. The boiler operator keeps track of water level in the drum and operates the feed pump as per the requirement to maintain a constant level (about half) of water inside the drum (Figure 5.32).

5.7.2 Pressure Gauge

The function of the pressure gauge is to indicate the steam pressure inside the boiler drum in bar or in kgf/cm^2 or in kN/m^2 gauge pressure. If the boiler is fitted with a superheater, one more pressure gauge fitted to the superheater header indicates the superheated steam pressure at any given instant. As the gauge pressure is always above atmospheric pressure, its value should be added to the atmospheric pressure in order to know the absolute pressure (Figure 5.33).

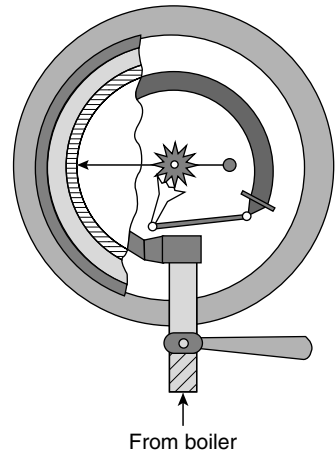

Fig. 5.33 Pressure Gauge

5.7.3 Steam Stop Valve or Junction Valve

Steam stop valve or *junction valve* are essentially the same. Conventionally, stop valves are smaller in size, whereas junction valves are larger. When the valve is mounted on the topmost portion of the steam drum, normally the valve is called *junction valve*. If it is connected in the steam pipe to regulate the flow of steam, the valve is known as *stop valve*.

The function of the steam stop valve or junction valve is to shut off the steam flow or to regulate the steam flow as per the requirement or demand (Figure 5.34).

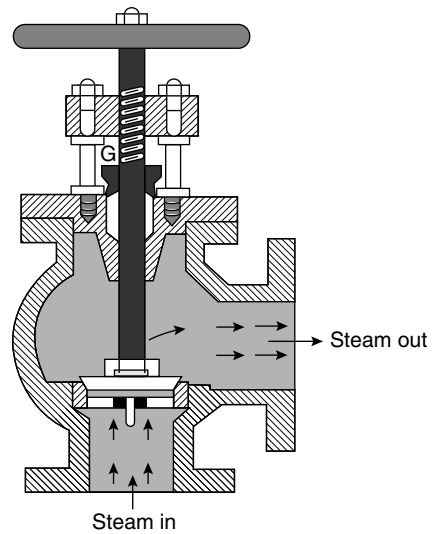

Fig. 5.34 Steam Stop Valve

5.7.4 Feed Check Valve

Feed check valve regulates the flow of feed water under pressure to the boiler drum. It is essentially a one-way valve and allows water to flow only in one direction, that is, towards the boiler drum. No water flows back from the boiler drum. It consists of two valves united together. One valve regulates the flow of water to the boiler drum or stops it completely, whereas another valve automatically prevents (operates by pneumatic pressure) water rushing back from the boiler (Figure 5.35).

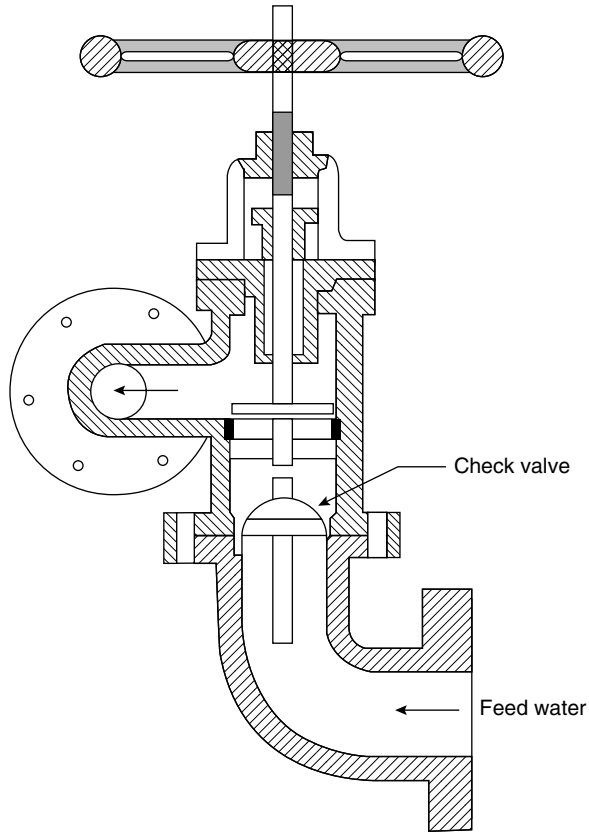

Fig. 5.35 Feed Check Valve

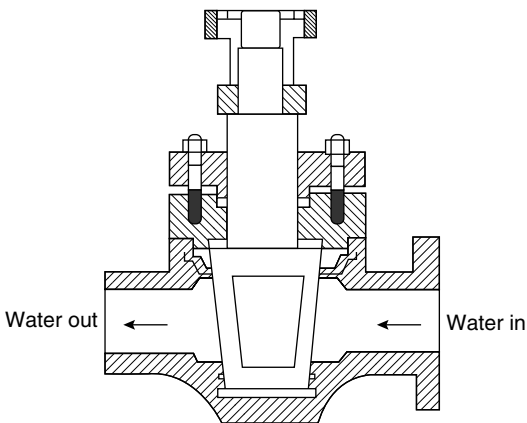

Fig. 5.36 Blow-Down Valve

5.7.5 Blow-Down Valve or Blow-Off-Cock

The function of the blow-down valve or blow-off cock is to remove the sludge or sediments collected at the bottom of the boiler drum from time to time. Whenever boiler cleaning and inspection are due water inside the tubes and in the boiler drum can be completely drained by operating the blow-down valve. Periodic blow-down is necessary to limit or to control the dissolved impurities in the feed water (Figure 5.36).

5.7.6 Fusible Plug

The function of the fusible plug is to protect the firebox crown plate or fire tube from burning due to excessive heating. This usually happens when the water level inside the drum becomes too low and the shell and crown plate are directly exposed to steam space. The gun metal fusible plug fitted to the crown plate melts if the shell of the crown plate is overheated and hence allows remaining water inside the shell to fall in the furnace. This extinguishes the fire in the furnace, and hence prevents further damages (Figure 5.37).

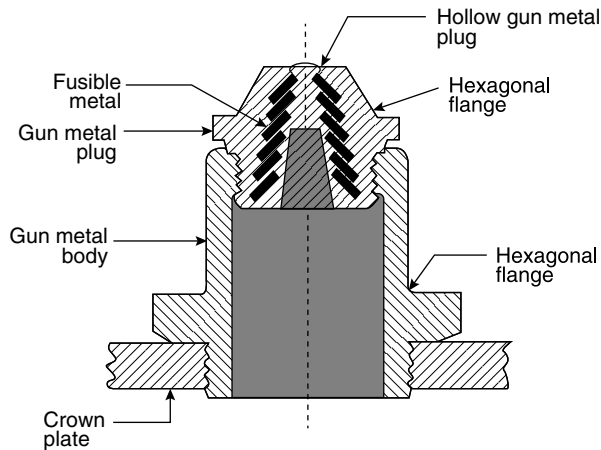

Fig. 5.37 Fusible Plug

5.7.7 Safety Valves

The function of the safety valve is to prevent the excessive steam pressure inside the boiler drum exceeding the design pressure. When the pressure inside the boiler drum exceeds the rated pressure, the safety valve automatically opens and discharges the steam to the atmosphere till normal working pressure is retained. This situation arises whenever furnace temperature increases causing excessive heat transfer or whenever steam demand suddenly drops.

Two types of safety valves are used in practice.

1. *Spring-loaded safety valve*

These valves are used in marine or locomotive boilers where there are chances of sudden jerk or vibration (Figure 5.38).

2. *Dead weight safety valve*

These valves are used only in stationary boilers such as Lancashire boiler or other low-capacity boilers. In this device, the upward steam pressure is balanced by the downward force of the dead weights acting on the valve.

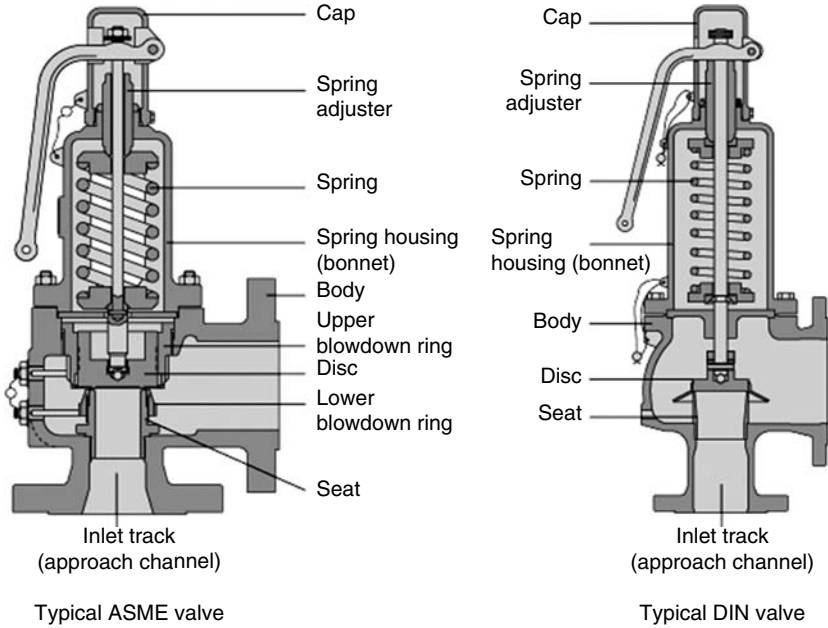

Fig. 5.38 *Spring-Loaded Safety Valve*

Draught System

7

Contents

7.1 Introduction to draught system

7.2 Air and supply systems (natural mechanical draught systems)

7.3 Chimneys

7.4 Calculations involving height of chimney to produce a given draught

7.1 INTRODUCTION TO DRAUGHT SYSTEM

Boiler draught is the pressure difference required to maintain constant flow of air into the furnace and to discharge the flue gases to the atmosphere through a chimney. Thus, boiler draught is one of the most essential systems of a thermal plant.

The total draught required to produce the current of air and to expel the flue gases is given as follows:

Total draught loss = Velocity head loss at the chimney exit + fuel bed resistance + head loss in equipments such as economizer, air heater, etc. + head loss in the chimney and ducts

$$\text{i.e., } H_t = H_v + H_b + H_e + H_{cd}$$

7.2 AIR AND SUPPLY SYSTEMS (NATURAL MECHANICAL DRAUGHT SYSTEMS)

Boiler draught is generated by using chimney, fan, steam jet or air jet, or a combination of both. Based on this, draught is classified as follows:

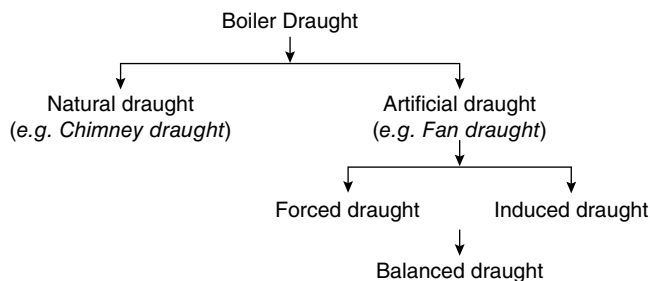

1. *Natural draught*

Natural draught is produced by making use of a chimney. A chimney is a vertical tubular structure that is made up of brick, steel or reinforced concrete. The draught produced by the chimney is due to the difference in temperature of hot flue gases inside the chimney and the atmospheric air. In addition, the height of the chimney above the furnace grate, weather conditions and boiler-operating conditions also have considerable effect on the amount of natural draught (Figure 7.1).

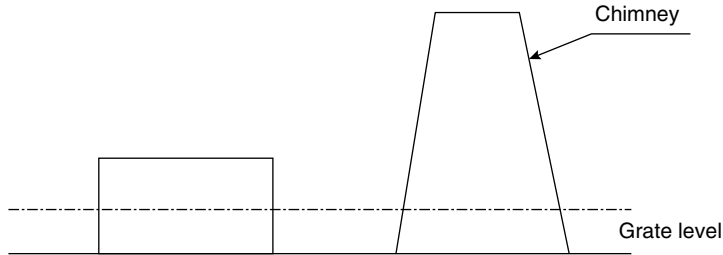

Fig. 7.1 *Natural Draught*

2. *Artificial or mechanical draught*

This type of draught is preferred when the draught produced by the chimney is not sufficient or when a certain draught is to be maintained irrespective of atmospheric temperature. In modern high-pressure boilers, the use of economizers, superheaters and air preheaters reduces the exit flue gas temperature considerably. However, this would necessitate an increased chimney height – the cost of which cannot be justified. By using artificial or mechanical draught, the height of the chimney can be considerably reduced. Mechanical draught is of two types: forced and induced.

(i) *Forced draught*

In the forced draught (FD) system (Figure 7.2), a blower is installed near the base of the boiler that blows air into the furnace. The pressure of air throughout its path is above atmospheric pressure. This system also uses a chimney to discharge hot flue gases into the atmosphere.

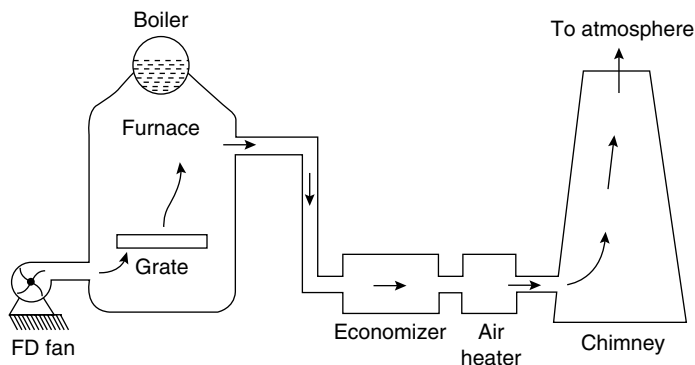

Fig. 7.2 *Forced Draught*

(ii) *Induced draught*

In the induced draught (ID) system, the blower is installed near the base of the chimney so as to facilitate sucking of flue gases from the furnace. Thus, pressure inside the furnace is reduced below atmospheric pressure, inducing outside air into the furnace. The heat in exhaust gases can be recovered as much as possible by installing an air preheater and economizer along the gas flow path. As the draught produced in this system is independent of flue gas temperature, care should be taken such that the fan handles gas at its lowest possible temperature. *The total draught produced by the system is equal to the sum of the fan and chimney draughts.*

However, when the furnace doors are opened for firing purpose, the air from outside rushes into the furnace and reduce the draught.

(iii) *Balanced draught*

A balanced draught system (Figure 7.3) combines the features of FD and ID. In the case of FD, when the furnace doors are opened, high-pressure air rushes outside and even blows out the fire entirely. In the case of ID, when the furnace doors are opened, atmospheric air enters the furnace and causes an imbalance in the draught. This difficulty is overcome by using *balanced draught*.

In this system, an FD fan installed near the boiler helps in overcoming the resistance of fuel bed by supplying sufficient air for combustion. An ID fan installed near the chimney base removes the flue gases that come from the furnace, allowing the furnace pressure to be maintained slightly below atmospheric pressure.

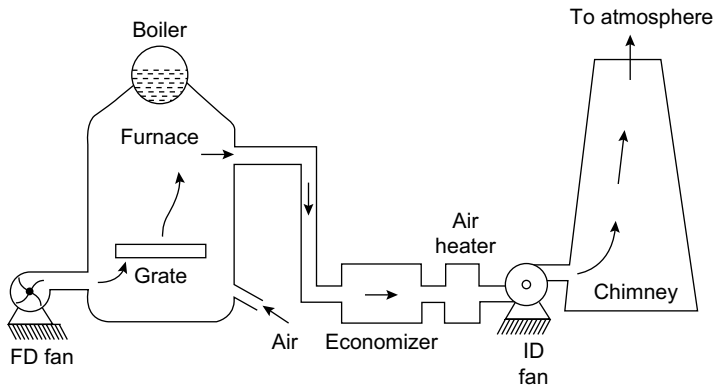

Fig. 7.3 *Balanced Draught*

3. *Steam jet draught*

Depending on the location of steam jet, draught produced may be either induced or forced.

(i) *Induced draught*

This type of draught is used in a boiler for a locomotive. When the locomotive is stationary, steam generated in the boiler is fed to the smoke box through the nozzles to create draught. When the locomotive moves, air enters through the dampers and makes its way through the grate and smoke box. In addition, exhaust steam from the engine cylinder is utilized to create the ID by passing it through the steam nozzle in the smoke box (Figure 7.4).

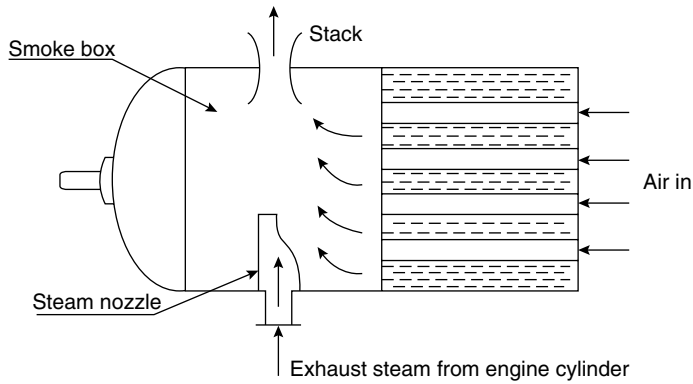

Fig. 7.4 Induced Steam Jet Draught

(ii) Forced draught

This type of draught is also known as *turbine draught* (Figure 7.5). In this case, steam from the boiler is throttled to a pressure of 1.5–2 bar and passed through a series of nozzles fitted to a diffuser pipe. The high-velocity steam that comes out from the nozzle drags the air column along with it, thereby creating a suction. Fresh air from outside enters the diffuser pipe. The kinetic energy of air and steam mixture is converted into pressure energy forcing air through the coal bed to the furnace. However, steam jet draught is used only as a booster in conjunction with chimney draught.

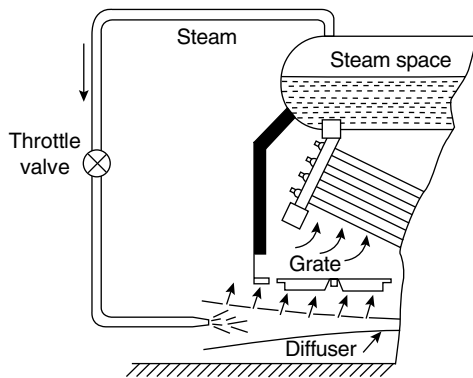

Fig. 7.5 Forced Steam Draught or Turbine Draught

Comparison of Forced and Induced Draughts

The advantages of the forced draught over the induced draught are listed below:

1. The size and power required by the induced draught fan is more than the forced draught because the induced draught fan handles more gases (air and fuel) and at elevated temperature. The volume of the gas handled by induced draught fan is much larger than the volume handled by forced draught fan due to high temperature of the gases, therefore the size of induced draught fan is 1.3 times the size of forced draught fan.
2. Water cooled bearings are required for induced draught fan to withstand the high temperatures of the flue gases.
3. There is no chance of air leakage in the furnace with forced draught as the pressure inside the furnace is above atmospheric pressure. There is continuous leakage of air in the furnace with induced draught as the pressure inside the furnace is less than the atmospheric pressure. This dilutes the combustion.
4. The flow of air through the grate and furnace is more uniform and it penetrates better into the fire bed when forced draught is used. The better penetration of air through the fuel bed and uniform flow improves the rate of burning.
5. When the doors are opened for firing in case of induced draught fan, there will be rush of cold air into the furnace and this reduces the draught through the system and reduces the heat transmission efficiency of the surface.

3.43. Steam Turbines

Steam turbine is a heat engine which uses the heat energy stored in steam and performs work. The main parts of a steam turbine are as follows :

(i) A rotor on the circumference of which a series of blades or buckets are attached. To a great extent the performance of the turbine depends upon the design and construction of blades. The blades should be so designed that they are able to withstand the action of steam and the centrifugal force caused by high speed. As the steam pressure drops the length and size of blades should be increased in order to accommodate the increase in volume. The various materials used for the construction of blades depend upon the conditions under which they operate. Steel or alloys are the materials generally used.

- (ii) Bearing to support the shaft.
- (iii) Metallic casing which surrounds blades, nozzles, rotor etc.
- (iv) Governor to control the speed.
- (v) Lubricating oil system.

Steam from nozzles is directed against blades thus causing the rotation. The steam attains high velocity during its expansion in nozzles and this velocity energy of the steam is converted into mechanical energy by the turbine. As a thermal prime mover, the

thermal efficiency of turbine is the usual work energy appearing as shaft power presented as a percentage of the heat energy available. High pressure steam is sent in through the throttle valve of the turbine. From it comes torque energy at the shaft, exhaust steam, extracted steam, mechanical friction and radiation.

Depending upon the methods of using steam, arrangement and construction of blades, nozzle and steam passages, the steam turbines can be classified as follows :

6.9 ADVANTAGES OF STEAM TURBINE OVER STEAM ENGINE

The various advantages of steam turbine are as follows :

- (i) It requires less space.
- (ii) Absence of various links such as piston, piston rod, cross head etc. make the mechanism simple. It is quiet and smooth in operation,
- (iii) Its over-load capacity is large.
- (iv) It can be designed for much greater capacities as compared to steam engine. Steam turbines can be built in sizes ranging from a few horse power to over 200,000 horse power in single units.
- (v) The internal lubrication is not required in steam turbine. This reduces to the cost of lubrication.
- (vi) In steam turbine the steam consumption does not increase with increase in years of service.
- (vii) In steam turbine power is generated at uniform rate, therefore, flywheel is not needed.
- (viii) It can be designed for much higher speed and greater range of speed.
- (ix) The thermodynamic efficiency of steam turbine is higher.

10.3.2 Compounding of Steam Turbines

If the steam pressure drops from boiler pressure to condenser pressure in a single stage, exit velocity of steam from the nozzle will become very high, and the turbine speed will be of the

order of 30,000 rpm or more. As turbine speed is proportional to steam velocity, the *carryover loss* or *leaving loss* will be more (10–12 per cent). Due to this very high speed, centrifugal stresses are developed on the turbine blades resulting in *blade failure*. To overcome all these difficulties, it is necessary to reduce the turbine speed by the method of compounding.

Compounding is the method of reducing blade speed for a given overall pressure drop. Compounding of steam turbines is done by the following methods.

10.3.2.1 Pressure Compounded Impulse Turbines

If a number of simple impulse stages are clubbed together, then the arrangement is known as pressure compounding. The arrangement contains one row of fixed blades or nozzles at the entry of each row of moving blades. The total pressure drop does not take place in the first row of nozzles, but is divided equally between all the nozzles as shown in Figure 10.4.

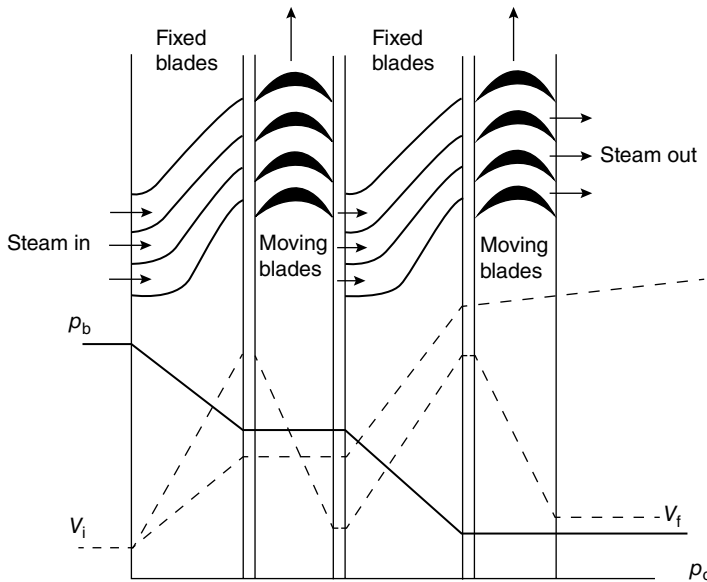

Fig. 10.4 A Simple Pressure Compounded Impulse Turbine

The steam from the boiler is passed through the first set of fixed nozzles (blades) in which it is partially expanded. The steam then passes over the first row of moving blades where almost all its velocity is absorbed. This complete expansion of steam is *one stage*. In the *next stage*, the steam again enters the second set of fixed nozzles and partially expands and enters the moving blades. Again the steam velocity is absorbed. This process continues till the steam reaches the condenser pressure, p_c .

Due to pressure compounding, a smaller transformation of heat energy into kinetic energy takes place. Hence, steam velocities become much lower and reduce the blade velocities and rotational speed.

10.3.2.2 Velocity Compounded Impulse Turbines

A simple velocity compounded impulse turbine is shown in Figure 10.5. It consists of a set of nozzles and a rotating wheel fitted with two or more rows of moving blades. One row of fixed blades between the moving blades directs steam from the nozzle over the moving blades.

The steam from the boiler expands in the nozzle and enters the first row of the moving blades. A portion of kinetic energy is absorbed by the blades before passing over the fixed blades or guide blades. Velocity slightly drops in guide blades before steam is sent to the second row of the moving blades. Steam does work on the second row of the moving blades losing its kinetic energy and leaves axially with residual velocity V_f . Due to this, the rotor speed decreases considerably.

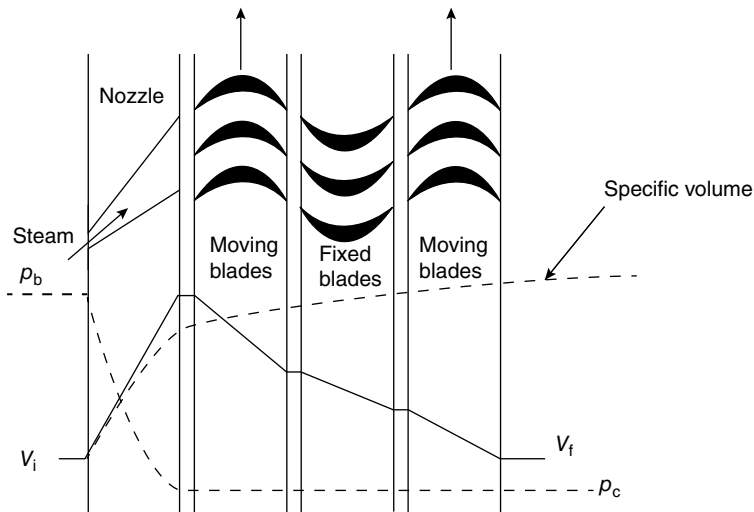

Fig. 10.5 A Simple Velocity Compounded Impulse Turbine

Advantages and disadvantages of velocity compounding

Advantages

- (i) Due to large enthalpy drop, the pressure drop in the nozzle's first stage is also large. This reduces stress in the turbine housing.
- (ii) Velocity compounding principle leads to a relatively large number of enthalpy drop per stage. Hence, fewer number of stages are required, which leads to low initial cost.
- (iii) With a single row, steam temperature used is about 300°C , which is high enough for ordinary cast iron to withstand. By using two rows, the steam temperature is also lowered and ordinary CI can be used, provided steam chest is constructed using stainless steel.
- (iv) Due to fewer number of stages, space required is less.

Disadvantages

- (i) Specific volume of steam continuously increases with more number of stages, imposing limitations to blade design.
- (ii) Friction losses become higher due to high-velocity steam at the blade outlet.
- (iii) As enthalpy drop per stage is large, efficiency ratio decreases with increased number of rows as shown in Figure 10.6.

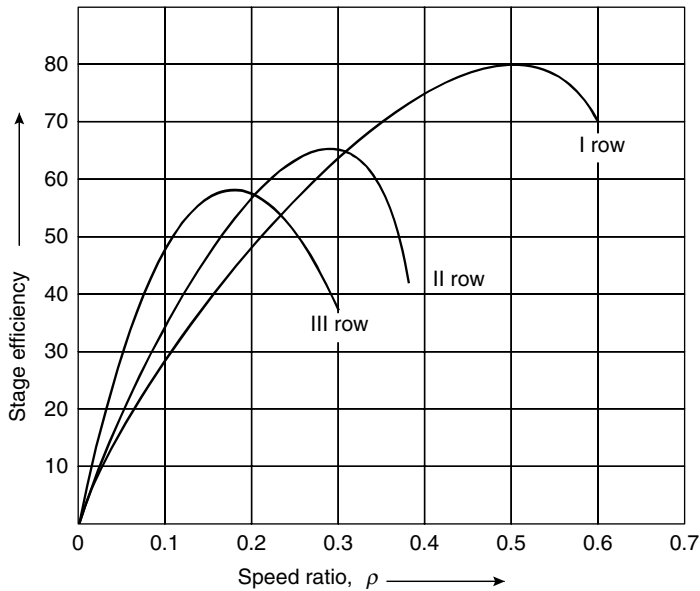

Fig. 10.6 Variation of Stage Efficiency with Speed Ratio

- (iv) As the work done per kilogram of steam decreases progressively with the number of stages, space, material cost and initial cost add up.

10.3.2.3 Pressure–Velocity Compounding

If pressure and velocity are both compounded using two or more number of stages by having a series arrangement of simple *velocity compounded* turbines on the same shaft, it is known as pressure–velocity compounding. In this type of turbine, both pressure compounding and velocity compounding methods are used. The total pressure drop of the steam is divided into two stages, and the velocity obtained in each stage is also compounded. Pressure drop occurs only in nozzles and remains constant throughout. As pressure drop is large in each stage, only a few stages are necessary. This makes the turbine more compact than the other two types. Pressure–velocity compounding (Figure 10.7) is used in *Curtis turbine*.

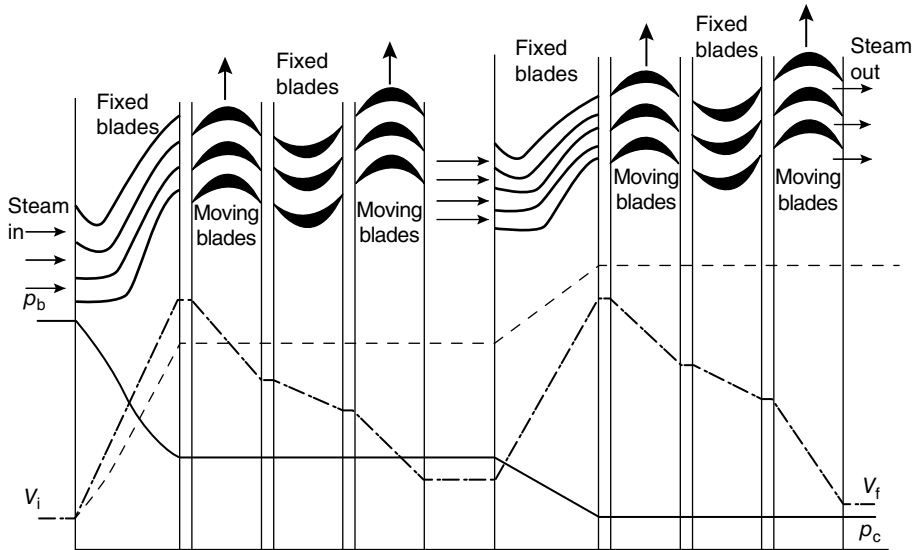

Fig. 10.7 Pressure–Velocity Compounding

10.3.3 Impulse Turbine Power and Related Calculations

10.3.3.1 Single-Stage Impulse Turbine

The essential parts of an impulse steam turbine are nozzles and blades. Steam expands in the nozzles producing high-velocity jet at the nozzle exit. Blades change the direction and hence momentum of the jet of steam. The force produced due to change in momentum propels the blades. Hence, it is of primary interest to estimate the propelling force that is applied at the turbine rotor. As force is due to *change in momentum* caused by change in direction of steam, the variation of steam velocity can be studied by drawing the velocity triangles. Impulse force acting on the blades can be calculated in the plane of rotation of blades tangential to the turbine runner.

Figure 10.8 shows the velocity diagram for an impulse turbine. Due to the expansion of steam in nozzles, steam comes out with an absolute velocity V_1 at an angle α_1 with the plane of moving blades. If the blade velocity is represented by u , then the relative velocity of steam with respect to the casing is V_{r1} . As steam flows over the blades, the relative velocity remains constant for an impulse turbine.

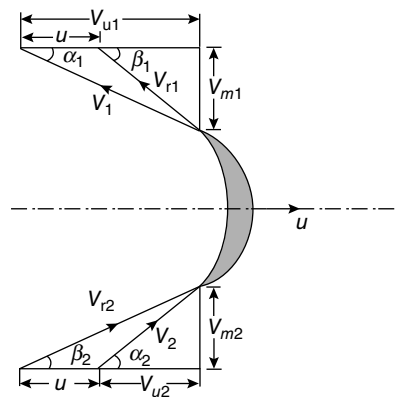

Fig. 10.8 Velocity Diagram for an Impulse Turbine

10.7 GOVERNING OF TURBINES

A governor is a device used to maintain constant speed of the turbine irrespective of the load applied to it. Figure 10.17 shows a centrifugal flyball-type governor. When the load on the turbine is deduced, speed of the turbine increases. This results in an increased centrifugal force, throwing the flyballs apart, away from the shaft centreline. Due to this, the sleeve raises, causing the main valve to close, via the fulcrum and the lever attached to the sleeve. This reduces steam flow rate to the turbine.

In an oil-operated servo system (see Figure 10.17), the force exerted by the governor is amplified to move a frictionless pilot valve, controlling the flow of oil into a piston. This piston

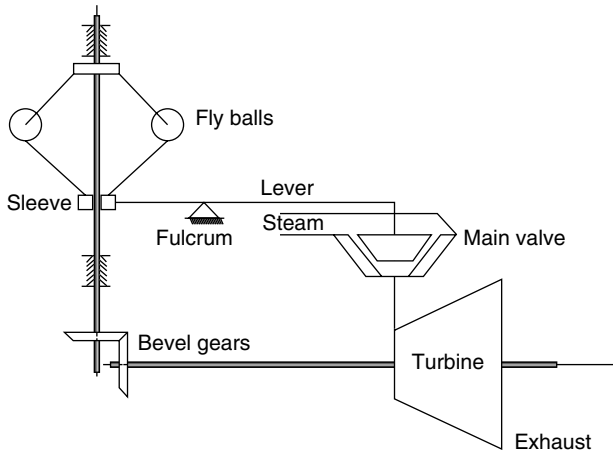

Fig. 10.17 A Centrifugal Flyball-Type Governor

operates with the high-pressure oil supplied to the governor valve in the desired position, thereby regulating the flow. The speed change of the governor from full-load condition to no-load condition varies between 3 and 4 per cent. The percentage change in regulated speed is given by the following equation:

$$\% \text{ change in regulated speed} = \frac{(N_F - N_0)}{N}$$

where N = speed at rated speed

N_0 = speed at no-load condition

N_F = Speed at full-load condition

Four different methods are available for governing a steam turbine. They are throttle governing, nozzle control governing, bypass governing and emergency governing. These are discussed below in detail.

1. Throttle governing

Power available at the shaft, P is given by $P = 2\pi NT$, where T is the torque and N is the shaft speed in revolutions per second. From the above equation, it is evident that as load decreases, the shaft speed increases. As the main valve is closed partially to maintain the speed, power generated by the turbine decreases. Due to this restricted entry of the steam, steam is throttled from the initial pressure of p_b to p_{b1} . Due to this, the enthalpy drop reduces from $(h_1 - h_2)$ to $(h_3 - h_4)$. The steam consumption reduces further when the throttle valve is closed further, establishing a linear relationship. Using Willan's line method, steam consumption rate in the turbine is given by the following equation:

$$m = a + bL,$$

where a = steam consumption under no-load conditions, kg/s
 b = specific steam consumption, kg/s/kW
 L = load on the turbine

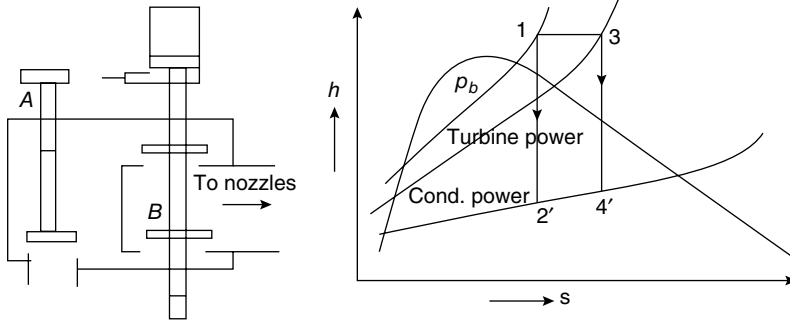

Fig. 10.18 Throttle Governor

The throttle valve is used to regulate steam flow during the start and stop of the turbine. In bigger turbines, the stop valve is hydraulically operated, whereas in smaller turbines, it could be manually operated. Figure 10.18 shows a throttle governing system.

2. Nozzle control governing

The major limitation of throttle governing is that the turbine efficiency reduces at low loads. Nozzle control governing is a better option in this case. As shown in Figure 10.19, the nozzles are arranged in sets, each set being controlled by a separate valve. When load on the turbine is decreased, the corresponding set of nozzles may be shut off.

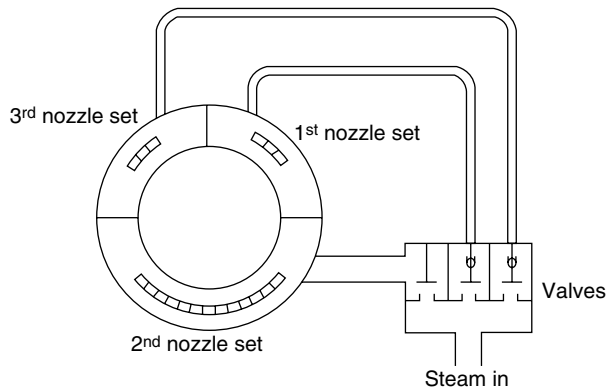

Fig. 10.19 Nozzle Control Governing

3. Bypass governing

Where the requirement is more for power, additional steam is supplied to the turbine by providing bypass valves. This is usually done at the later stages of the turbine, and in a throttle-governed turbine as shown in Figure 10.20.

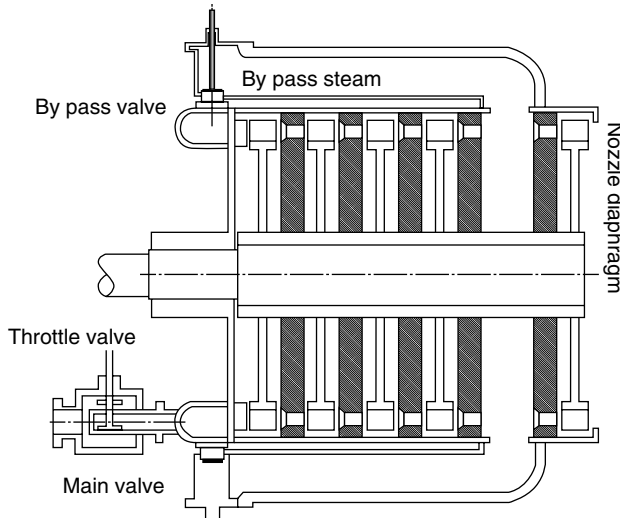

Fig. 10.20 Bypass Governing

4. Emergency governor

An emergency governor helps in tripping (stopping the turbine) when the turbine overspeeds (110 per cent of its rated speed) or the lubrication system fails or when balancing of the system is improper or condenser vacuum is disturbed (less). A typical emergency trip system contains a pin or weight placed on the turbine shaft, acting against a spring pressure. During normal operation, the centrifugal force acting on the pin is opposed by the spring pressure. Beyond the overspeed point, the centrifugal force becomes dominant, forcing the pin out and thereby striking a trigger. Due to this action, the spring closes the stop valve, shutting down the turbine.

1.6.3 Condensers

1. Introduction

A steam condenser is a closed vessel into which the steam is exhausted, and condensed after doing work in an engine cylinder or turbine. A steam condenser has the following two objects: The steam condensing plant is shown in Figure 1.18.

1. The primary object is to maintain a low pressure (below atmospheric pressure) so as to obtain the maximum possible energy from steam and thus to secure a high efficiency.
2. The secondary object is to supply pure feedwater to the hot well, from where it is pumped back to the boiler.

Note: The low pressure is accompanied by low temperature and thus all condensers maintain a vacuum under normal conditions. The condensed steam is called condensate. The temperature of condensate is higher on leaving the condenser than that of circulating water at inlet. It is thus obvious, that the condensate will have a considerable liquid heat.

2. Classification

The steam condensers may be broadly classified in to the following two types, depending upon the way in which the steam is condensed:

- A. Jet condensers or mixing type condensers, and
- B. Surface condensers or non-mixing type condensers.

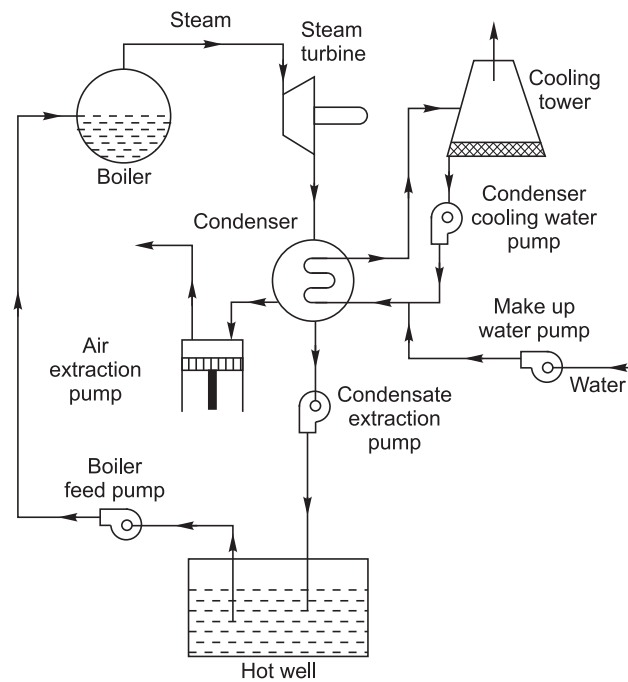

Fig 1.18. Steam Condensing plant

A. Jet Condensers

These days, the jet condensers are seldom used because there is some loss of condensate during the process of condensation and high power requirements for the pumps used. Moreover, the condensate cannot be used as feedwater to the boiler as it is not free from salt. However, jet condensers may be used at places where water of good quality is easily available in sufficient quantity.

Types of Jet Condensers

The jet condensers may be further classified, on the basis of the direction of flow of the condensate and the arrangement of the tubing system, in to the following four types:

1. Parallel flow jet condenser,
2. Counter flow or low level jet condenser,
3. Barometric or high level jet condenser and
4. Ejector condenser,

These condensers are discussed, in detail, in the following pages.

Parallel Flow Jet Condensers

In parallel flow jet condensers, both the steam and water enter at the top, and the mixture is removed from the bottom.

The principle of this condenser is shown in Figure 1.19. The exhaust steam is condensed when it mixes up with water. The condensate, cooling water and air flow downwards and are removed by two separate pumps known as air pump and condensate pump. Sometimes, a single pump known as wet air pump, is also used to remove both air and condensate. But the former gives a greater vacuum. The condensate pump delivers the condensate to the hot well, from where surplus water flows to the cooling water tank through an overflow pipe.

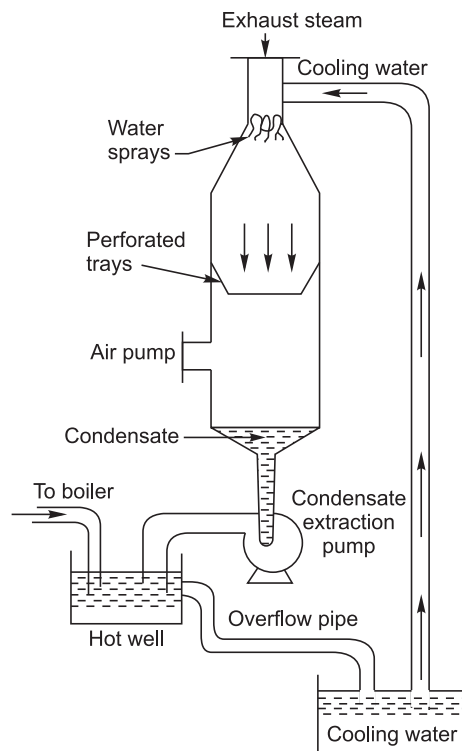

Fig. 1.19. Parallel Flow Jet Condenser

Counter Flow or Low Level Jet Condensers

In counter flow or low level jet condensers, the exhaust steam enters at the bottom, flows upwards and meets the down coming cooling water.

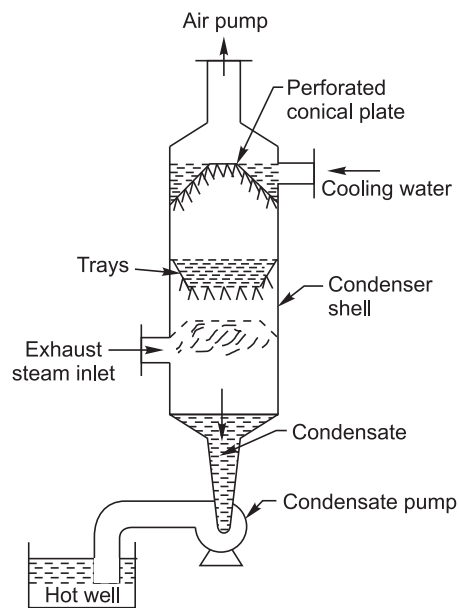

Fig. 1.20. Counter Flow Jet Condenser

The vacuum is created by the air pump, placed at the top of the condenser shell. This draws the supply of cooling water, which falls in a large number of jets, through perforated conical plate as shown in Figure 1.20. The falling water is caught in the trays, from which it escapes in a second series of jets and meets the exhaust steam entering at the bottom. The rapid condensation occurs, and the condensate and cooling water descends through a vertical pipe to the condensate pump, which delivers it to the hot well.

Barometric or High Level Jet Condensers

These condensers are provided at a high level with a long vertical discharge pipe as shown in Figure 1.21. In high level jet condensers, exhaust steam enters at the bottom, flows upwards and meets the down coming cooling water in the same way as that of low level jet condenser. The vacuum is created by the air pump, placed at the top of the condenser shell. The condensate and cooling water descends through a vertical pipe to the hot well without the aid of any pump. The surplus water from the hot well flows to the cooling water tank through an overflow pipe.

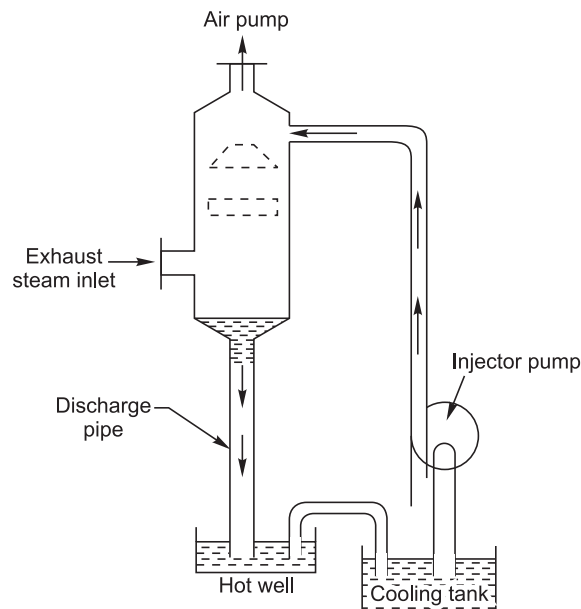

Fig. 1.21. High Level Jet Condensers

Ejector Condensers

In ejector condensers, the steam and water mix up while passing through a series of metal cones. Water enters at the top through a number of guide cones. The exhaust steam enters the condenser through non-return valve arrangement. The steam and air then passes through the hollow truncated cones. After that it is dragged into the diverging cones where its kinetic energy is partly transformed to pressure energy. The condensate and cooling water is then discharged to the hot well as shown in Figure 1.22.

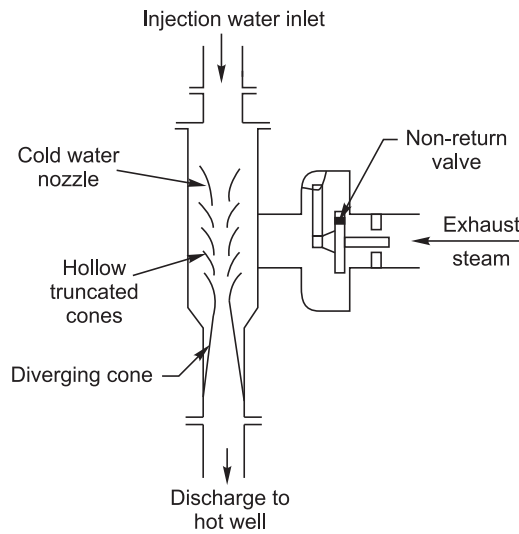

Fig. 1.22. Ejector Condenser

B. Surface Condensers

A surface condenser has a great advantage over the jet condensers, as the condensate does not mix up with the cooling water. As a result of this, whole condensate can be reused in the boiler. This type of condenser is essential in ships which can carry only a limited quantity of fresh water for the boilers. It is also widely used in land installations, where inferior water is available or the better quality of water for feed is to be used economically.

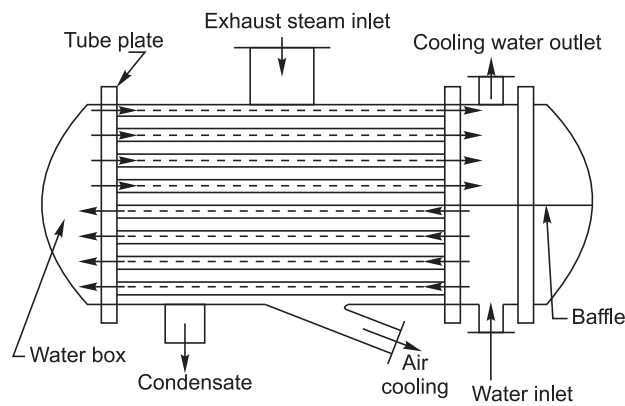

Fig. 1.23. Surface Condenser

Figure 1.23 shows a longitudinal section of a two pass surface condenser. It consists of a horizontal cast iron cylindrical vessel packed with tubes, through which the cooling water flows. The ends of the condenser are cut-off by vertical perforated type plates into which water tubes are fixed. This is done in such a manner that the leakage of water into the centre condensing space is prevented.

The water tubes pass horizontally through the main condensing space for the steam. The steam enters at the top and is forced to flow downwards over the tubes due to the suction of the extraction pump at the bottom. The cooling water flows in one direction through the lower half of the tubes and returns in opposite direction through the upper half, as shown in Figure 1.23.

Types of Surface Condensers

The surface condensers may be further classified on the basis of the direction of flow of the condensate, the arrangement of tubing system and the position of the extraction pump, into the following four types:

1. Down flow surface condenser,
2. Central flow surface condenser,
3. Regenerative surface condenser and
4. Evaporative Condenser.

These condensers are discussed, in detail, in the following pages.

Down Flow Surface Condensers

In down flow surface condensers, the exhaust steam enters at the top and flow downwards over the tubes due to force of gravity as well as suction of the extraction pump fitted at the bottom. The condensate is collected at the bottom and then pumped by the extraction pump. The dry air pump suction pipe, which is provided near the bottom, is covered by a baffle so as to prevent the entry of condensed steam into it, as shown in Figure 1.24.

As the steam flows perpendicular to the direction of flow of cooling water (inside the tubes), this is also called a cross surface condenser.

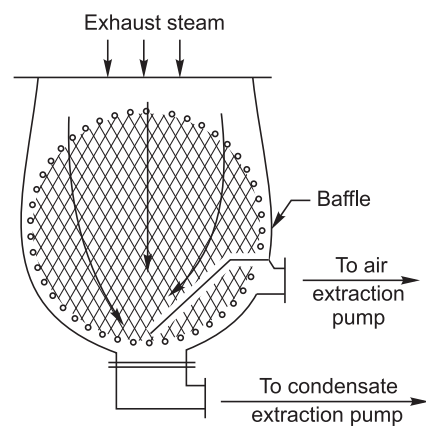

Fig. 1.24. Downflow Surface Condenser

Central Flow Surface Condensers

In central flow surface condensers, the exhaust steam enters at the top and flow downwards. The suction pipe of the air extraction pump is placed in the centre of the tube nest as shown in Figure 1.25. This causes the steam to flow radially inwards over the tubes towards the suction pipe. The condensate is collected at the bottom and then pumped by the extraction pump. The central flow surface condenser is an improvement over the down flow type as the steam is directed radially inwards by a volute casing around the tube nest. It, thus, gives an access to the whole periphery of the tubes.

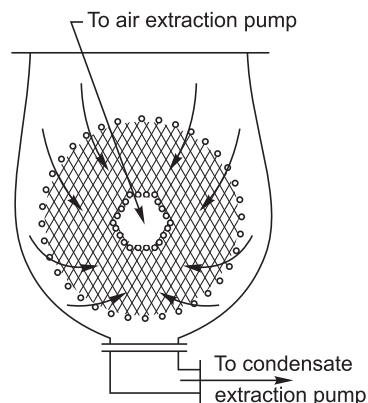

Fig. 1.25. Central Flow Surface Condensers

Regenerative Surface Condensers

In regenerative surface condenser, the condensate is heated by a regenerative method. The condensate after leaving the tubes is passes through the exhaust steam from the engine or turbine. It thus, raises its temperature for use as feed water for the boiler.

Evaporative Condenser

The steam to be condensed enters at the top of a series of pipes outside of which a film of cold water is falling. At the same time, a current of air circulates over the water film, causing rapid evaporation of some of the cooling water. As a result of this, the steam circulating inside the pipe is condensed. The remaining cooling water is collected at an increased temperature and is reused. Its original temperature is restored by the addition of the requisite quantity of cold water.

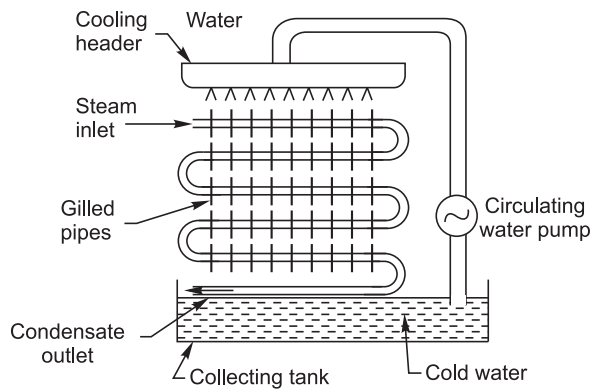

Fig. 1.26. Evaporative Condenser

The evaporative condensers are provided when the circulating water is to be used again and again. These condensers consist of sheets of gilled piping, which is bent backwards and forward and placed in a vertical plane, as shown in Figure 1.26.

3. Comparison of Jet and Surface Condensers

Following are the important points of comparison between jet and surface condensers:

<i>S. No.</i>	<i>Jet condensers</i>	<i>Surface condensers</i>
1.	Cooling water and steam are mixed up.	Cooling water and steam are not mixed up.
2.	Less suitable for high capacity plants.	More suitable for high capacity plants.
3.	It requires less quantity of circulating water. Condensate is wasted.	It requires a larges quantity of circulating water.
4.	The condensing plant is economical and simple.	Condensate is reused. The condensing plant is costly and complicated.
5.	Its maintenance cost is low.	Its maintenance cost is high.
6.	More power is required for air pump.	Less power is required for air pump.
7.	High power is required for water pumping.	Less power is required for water pumping.

11.1.1 Function of a Condenser

The primary function of the condenser is to condense the exhaust steam from the turbine. In doing so, high-quality feedwater can be reused in the cycle. In addition to this, a much more useful function is performed by the condenser. The steam exhausted in the turbine is condensed in the condenser at a low pressure (vacuum) by circulating cooling water. This pressure is equal to the saturation pressure corresponding to the condensing pressure of steam, and it is a function of cooling water temperature. Thus, the lower the exhaust pressure, the greater the turbine work. By lowering the turbine back pressure, the condenser increases the turbine work, increases the plant efficiency and reduces steam flow for a given plant output.

11.1.2 Elements of a Condensing Plant

Figure 11.2 shows a schematic diagram of a modern condensing plant. Elements of such a plant are condenser, condensate extraction pump, condenser cooling water recirculation pump, makeup water pump, air ejector pump, boiler feed pump and cooling tower.

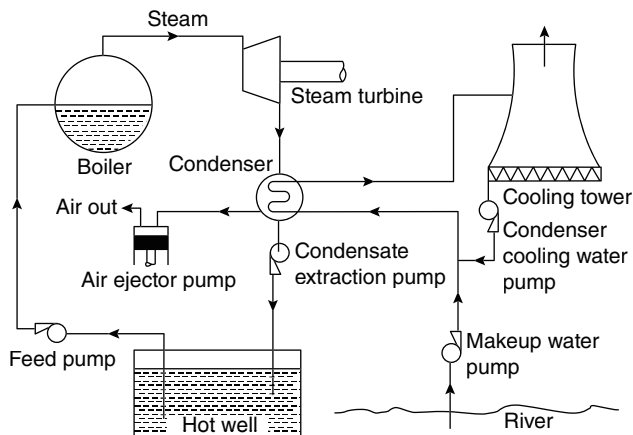

Fig. 11.2 Steam Condensing Plant

1. *Condenser*

The primary function of the condenser is to condense steam that comes out of the turbine. It is a shell and tube heat exchanger in which heat exchange takes place between cold circulating water and hot steam. As the requirement of cooling water is extremely large, a steam condensing plant should be installed near a water source.

2. *Condensate extraction pump*

The function of the condensate extraction pump is to extract the condensate (at vacuum) from the condenser and feed it to the hot well.

3. *Cooling water re-circulating pump*

The function of the condensate cooling water re-circulating pump is to supply cooling water coming from the cooling tower back to the condenser.

4. *Makeup water pump*

The function of the makeup water pump is to supply makeup water to the condenser. Makeup water is necessary to account for water loss due to leakage and evaporation.

5. *Air ejector pump*

The function of the air ejector pump is to eject air that has leaked into the condenser through the sealings. Thus, it maintains constant vacuum in the condenser.

6. *Boiler feed pump*

The function of the boiler feed pump is to supply high-pressure feedwater to the boiler drum. It is a multi-stage centrifugal pump that operates above boiler pressure.

7. *Cooling tower*

Cooling tower is necessary whenever the source of water near the steam plant is not large. It is a hyperbolic structure in which condensate water coming from the condenser is cooled either naturally or artificially. In a cooling tower, hot condensate is cooled by evaporating water itself. Due to this, some portion of cooling water is lost to the atmosphere. This loss is compensated by using makeup water.

11.4 COOLING TOWER

In large power plants, cooling towers are used in place of cooling ponds. A cooling tower is a wooden or metallic rectangular structure, with packed baffling devices. The hot water is delivered to the top of tower and falls down through the tower and is broken into small particles while passing over the baffling devices. Air enters the towers at the bottom and flows upwards and cools the water. The hot air leaves the tower at the top. The cooled water falls down into a tank below the tower from where it can again be circulated to the condenser.

11.4.1 Types

In modern power plants, condensate water is cooled by using a cooling tower. Cooling towers are basically classified as *wet cooling tower* and *dry cooling tower*. Further, they may either be forced draught (mechanical draft) or natural draft cooling towers depending on the mode of cooling.

11.4.1.1 Wet Cooling Towers

In wet cooling towers, water and air come in direct contact. Heat in water is dissipated by (i) the addition of sensible heat to air, (ii) evaporation of a portion of re-circulated water and (iii) addition of sensible heat to the water due to terminal temperature difference.

Figure 11.10 shows a wet cooling tower with natural draft. Hot water from the plant enters the distributor system where water is sprayed over horizontally set *fill* or *packing*. Air and water are thoroughly mixed by fill as water splashes down from one fill level to the next due to gravity. Outside air enters the tower through *louvers* from the sides of the tower. The heat and mass transfer (evaporation) between water and air is enhanced due to intimate mixing. Water gets cooled and is collected in a concrete basin at the bottom of the tower. Hot but moist air leaves the tower from the top. The cold water is re-circulated using a pump.

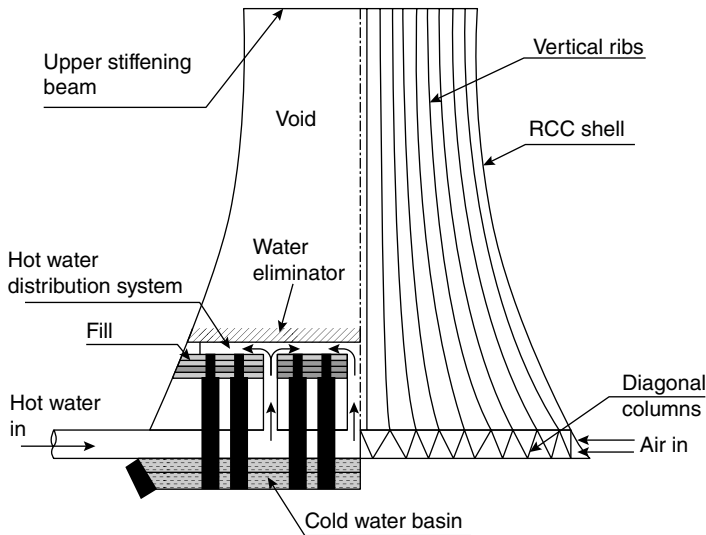

Fig. 11.10 Natural Draft Counter-Flow Cooling Tower

11.4.1.2 Dry Cooling Towers

In dry cooling tower, circulating water is passed through finned tubes over which cooling air is passed. Heat is rejected to the air in the form of sensible heat. A dry cooling tower may either be natural draft type or forced draft type. These types are cheaper than wet types of cooling towers. Figure 11.11 shows a direct, dry cooling tower.

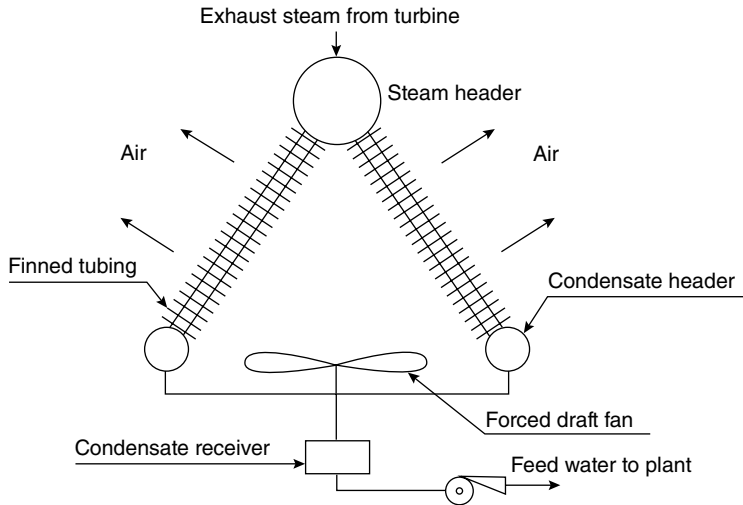

Fig. 11.11 Direct Dry Cooling Tower

Exhaust steam from turbine is admitted to a steam header (to minimize pressure drop). Steam gets condensed as it passes down through finned tubes arranged in parallel rows. Heat transfer is effected either by natural circulation of air or by forced circulation of air using a forced draft fan. The condensate collected in the receiver is re-circulated.

11.4.2 Principle of Operation and Performance

According to the nature of air draught, the cooling towers are classified as follows:

- (i) Atmospheric cooling tower
- (ii) Natural draught cooling tower
- (iii) Mechanical draught cooling tower

Based on the type of draught, mechanical draught cooling tower can be further classified as follows:

- (a) Induced draught cooling tower
- (b) Forced draught cooling tower
- (c) Combined induced and forced draught cooling towers (hybrid cooling tower)

The working principle of all the above types of cooling towers is described below.

(i) Atmospheric cooling tower

Figure 11.12 shows an atmospheric cooling tower. The hot water is delivered at the topmost tray, and it falls down from one tray to another until it reaches the tank below the tower. The water is cooled by air flowing across the tower. To increase the rate of cooling, water is sprayed through nozzles from the top. The number of decks of trays depends on the load of the plant. This type of cooling tower is used only for small capacity power plants.

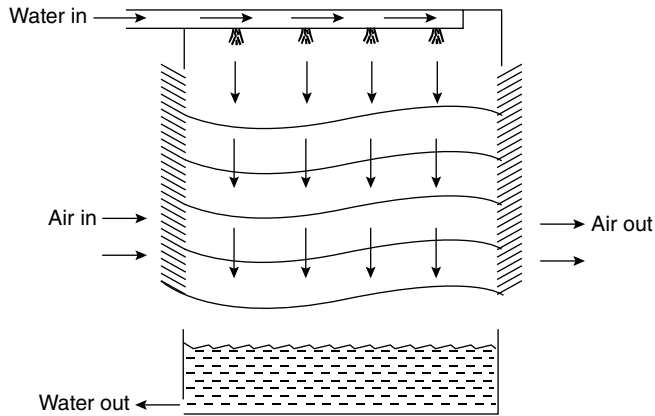

Fig. 11.12 Atmospheric Cooling Tower

(ii) Natural draught cooling towers

Natural draft towers are typically about 120 m high, depending on the differential pressure between the cold outside air and the hot humid air on the inside of the tower as the driving force. These towers do not use fans for draught generation. Depending on climatic and operating requirement conditions, selection on whether the natural or mechanical draft towers is done. Figure 11.13 shows a natural draught cooling tower.

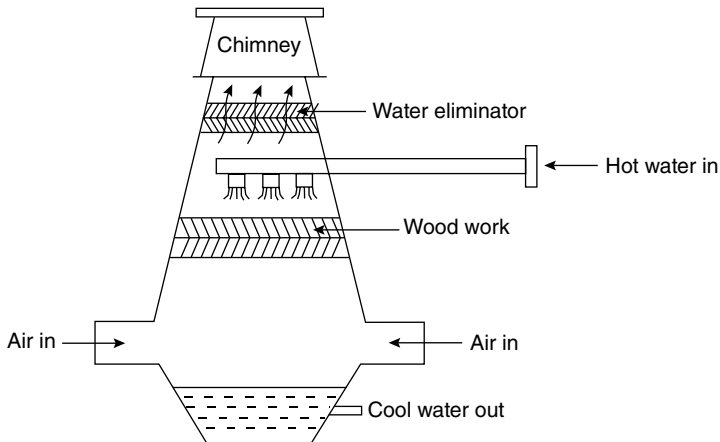

Fig. 11.13 Natural Draught Cooling Tower

In natural draught cooling towers, the flow of air occurs due the natural pressure head caused by density difference between the cold outside air and hot humid air inside.

In this tower, wooden hurdles and distributing trays are provided for spreading the water and for breaking it into small particles. The hot water from the condenser is pumped to a height of

9–15 m and enters the tower and then gets distributed over the wood work and trays. The hot water then falls down, and the steam vapours that are lighter than air will rise upwards. This will create natural draught and air will enter from the bottom of the tower that is open to atmosphere. The rising air meets the falling spray of hot water and cools it. The hot air along with some vapour will leave the tower at the top and cold water will fall down into the pond below the tower and get circulated through the condenser again. Water eliminator prevents the escape of water particles by the air leaving the tower. The disadvantage of natural draught cooling tower is that to produce large draught, the tower should be very high.

11.4.2.1 Hyperbolic Natural Draft Cooling Tower

Hyperbolic natural draft cooling towers work best when the difference between cold water and WBT of air ($T_{wbt} - T_{wi}$) is equal to or is greater than the difference between hot water and cold water temperature, that is, when approach is equal to or greater than the cooling range. Therefore, they are preferred when operating conditions have low WBT and high relative humidity. Figure 11.14 shows a typical hyperbolic cooling tower.

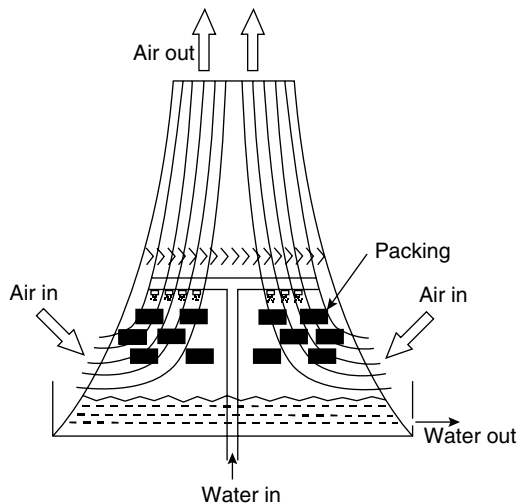

Fig. 11.14 Hyperbolic Cooling Tower

Although initial cost may be higher, the saving in fan power, longer life and less maintenance are favourable features of this tower.

Advantages

The advantages of hyperbolic tower over mechanical towers are listed below:

- (i) The hyperbolic towers have a cooling capacity comparable with that of induced draft cooling towers, and they also require considerably less ground area.
- (ii) Since no fans are needed, power cost and auxiliary equipments are eliminated; therefore, operating and maintenance costs are consequently reduced. It gives more or less trouble-free operation.

- (iii) Hyperbolic tower's chimney shape creates its own draft and ensures efficient operation even when there is no wind.
- (iv) Ground fogging and warm air recirculation that are often the most common problems faced with mechanical draft installations are also avoided in hyperbolic towers.
- (v) The towers may be as high as 125 m and 100 m in diameter at the base with the capability of withstanding winds of well over 100 mph. These are more or less self-supported structures.
- (vi) The enlarged top of the tower allows water to fall out of suspension.

Drawbacks

The major drawbacks of this tower are listed below:

- (i) Its cost is considerably high.
- (ii) Its performance varies with the seasonal changes in DBT and RH of air.

The hyperbolic towers are almost often selected over the mechanical draft towers under the following operating conditions:

- (a) A combination of low WBT and high inlet and outlet water temperature exists, that is, broad cooling range and long cooling approach.
- (b) Heat load is heavy during winter.
- (c) It is also more favourable over mechanical draft as central station size increases.

(iii) *Mechanical draught cooling tower*

In these towers, the draught of air is produced mechanically by means of propeller fans. They give higher efficiency, reduce spray and windage losses and require less ground area. Mechanical draft towers use fans (one or more) to move large quantities of air through the tower. The air flow in these towers may be either cross flow or counter flow with respect to the falling water. In cross flow towers, airflow is horizontal in the filled portion of the tower; whereas in counter flow, the air flow is in the opposite direction of the falling water.

The counter-flow tower requires less floor area than a cross flow tower but is taller for a given capacity. The cross flow towers have low-pressure drop in relation to their capacity and consume lower fan power, and hence have lower energy costs.

All mechanical towers must be properly located in order to ensure that the air diffuses freely without recirculation through the tower, and that the air intakes are not restricted. Cooling towers should be located as near as possible to the refrigeration systems they serve. If they are located below the refrigeration system, then the condenser water drains out of the system through the tower basin when the system is shut down.

11.4.2.2 Forced Draft Cooling Towers

The forced draft tower has the fan, basin and piping located within the tower structure. In this model, the fan is located at the base. There are no louvered exterior walls. Instead, the structural steel or wood framing is covered with panelling made of aluminium, galvanized steel or asbestos cement boards (see Figure 11.15).

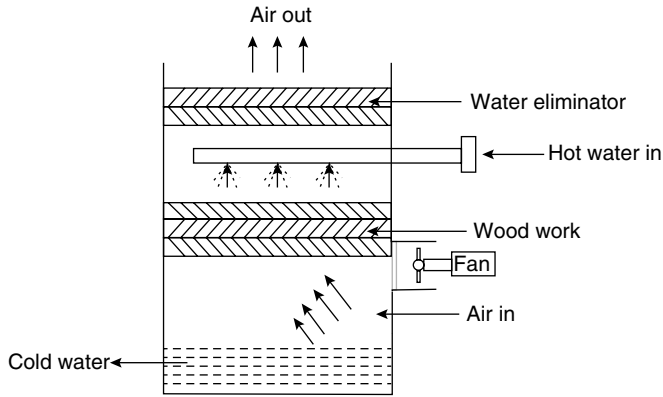

Fig. 11.15 Mechanical Draught Cooling Tower

In forced draught cooling, tower fan is located at the base of the tower and the air is blown by the fan up through the descending water. The entrained water is removed by water eliminator at the top.

11.4.2.3 Induced Draft Cooling Towers

In induced draught cooling towers, the fan is located at the top of the tower and draws the air in through the trays and discharges at the top through fan casing (see Figure 11.16).

Induced draught is considered to be better than forced draught because the power requirement is high for forced draught and the maintenance of fan is costlier. The induced draught occupies less space as the fan drives are placed at the top of the tower; the cooling effect is distributed across the entire cross section of the tower. Fans handle warm air, hence they are non-freezing. Since air leaves at a high speed, it is non-circulating.

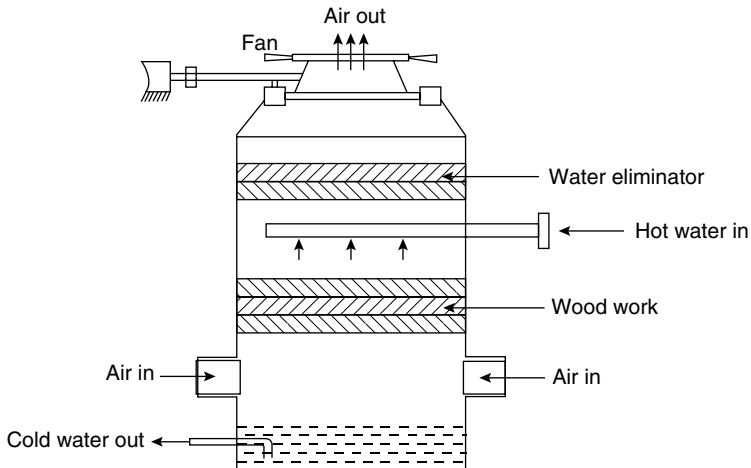

Fig. 11.16 Induced Draught Cooling Tower

11.4.2.4 Hybrid Draft Cooling Towers

These towers utilize mechanical draft fans to augment airflow and are also referred to as fan-assisted natural draft towers. This minimizes the power required for the air movement, with least-possible stack cost impact. Properly designed fans may need to be operated only during periods of high ambient and peak loads (see Figure 11.17).

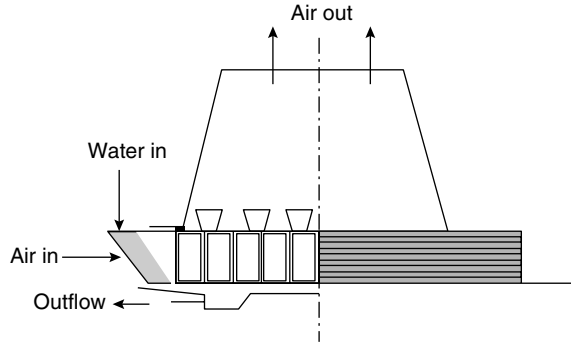

Fig. 11.17 Hybrid Cooling Tower

10.7.1 FUSION

Energy is produced in the sun and stars by continuous fusion reactions in which four nuclei of hydrogen fuse in a series of reactions involving other particles that continually appear and disappear in the course of the reactions, such as He, nitrogen, carbon, and other nuclei, but culminating in one nucleus of helium and two positrons resulting in a decrease in mass of about 0.0276 amu, corresponding to 25.7 MeV.



The heat produced in these reactions maintains temperatures of the order of several million degrees in their cores and serves to trigger and sustain succeeding reactions. On earth, although fission preceded fusion in both weapons and power generation, the basic fusion reaction was discovered first, in the 1920s, during research on particle accelerators. Artificially produced fusion may be accomplished when two light atoms fuse into a larger one as there is a much greater probability of two particles colliding than of four. The 4-hydrogen reaction requires, on an average, billions of years for completion, whereas the deuterium-deuterium reaction requires a fraction of a second. To cause fusion, it is necessary to accelerate the positively charged nuclei to high kinetic energies, in order to overcome electrical repulsive forces, by raising their temperature to hundreds of millions of degrees resulting in a plasma. The plasma must be prevented from contacting the walls of the container, and must be confined for a period of time (of the order of a second) at a minimum density. Fusion reactions are called *thermonuclear* because very high temperatures are required to trigger and sustain them. Table 10.2 lists the possible fusion reactions and the energies produced by them.

Table 10.2

Fusion reaction			Energy per reaction, MeV
Number	Reactants	Products	
1	D + D	T + p	4
2	D + D	He ³ + n	3.2
3	T + D	He ⁴ + n	17.6
4	He ³ + D	He ⁴ + p	18.3

n, *p*, D, and T are the symbols for the neutron, proton, deuterium and tritium respectively.

Many problems have to be solved before an artificially made fusion reactor becomes a reality . The most important of these are the difficulty in generating and maintaining high temperatures and the instabilities in the medium (plasma), the conversion of fusion energy to electricity, and many other problems of an operational nature. Fusion power plants will not be covered in this text.

10.7.2 Fission

Unlike fusion, which involves nuclei of similar electric charge and therefore requires high kinetic energies, fission can be caused by the neutron, which, being electrically neutral, can strike and fission the positively charged nucleus at high, moderate, or low speeds without being repulsed. Fission can be caused by other particles, but neutrons are the only practical ones that result in a sustained reaction because two or three neutrons are usually released for each one absorbed in fission. These keep the reaction going. There are only a few fissionable isotopes U^{235} , Pu^{239} and U^{233} are fissionable by neutrons of all energies.

The immediate (prompt) products of a fission reaction, such as Xe^0 and Sr^{94} above, are called fission fragments. They, and their decay products , are called fission products. Fig. 10.4 shows fission product data for U^{235} by thermal and fast neutrons and for U^{233} and Pu^{239} by thermal neutrons 1841. The products are represented by their mass numbers.

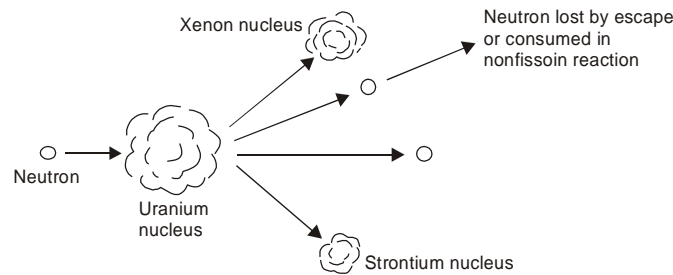

Fig. 10.3

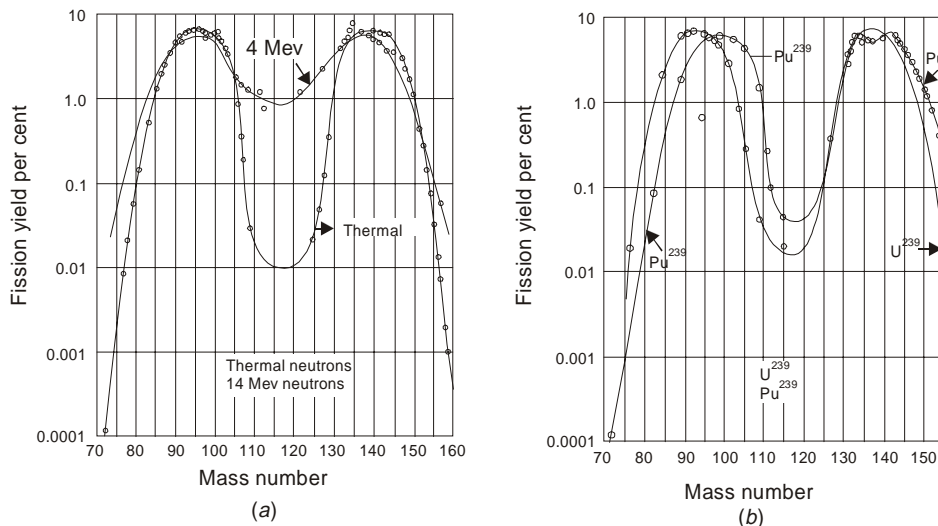

Fig. 10.4

10.10 NUCLEAR REACTOR

10.10.1 PARTS OF A NUCLEAR REACTOR

A nuclear reactor is an apparatus in which heat is produced due to nuclear fission chain reaction. Fig. 10.6 shows the various parts of reactor, which are as follows :

1. Nuclear Fuel
2. Moderator
3. Control Rods
4. Reflector
5. Reactors Vessel
6. Biological Shielding
7. Coolant.

Fig. 10.6 shows a schematic diagram of nuclear reactor.

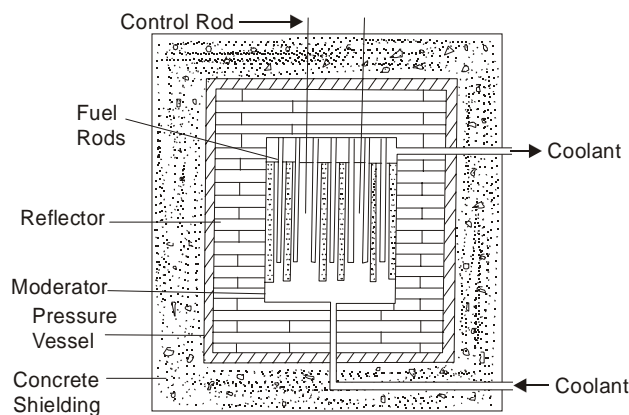
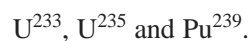

Fig. 10.6. Nuclear Reactor.

10.10.2 NUCLEAR FUEL

Fuel of a nuclear reactor should be fissionable material which can be defined as an element or isotope whose nuclei can be caused to undergo nuclear fission by nuclear bombardment and to produce a fission chain reaction. It can be one or all of the following



Natural uranium found in earth crust contains three isotopes namely U^{234} , U^{235} and U^{238} and their average percentage is as follows :

$$U^{238} \text{ — } 99.3\%$$

$$U^{235} \text{ — } 0.7\%$$

$$U^{234} \text{ — Trace}$$

Out of these U^{235} is most unstable and is capable of sustaining chain reaction and has been given the name as primary fuel. U^{233} and Pu^{239} are artificially produced from Th^{232} and U^{238} respectively and are called secondary fuel.

Pu^{239} and U^{233} so produced can be fissioned by thermal neutrons. Nuclear fuel should not be expensive to fabricate. It should be able to operate at high temperatures and should be resistant to radiation damage.

Uranium deposits are found in various countries such as Congo, Canada, U.S.A., U.S.S.R., Australia.

The fuel should be protected from corrosion and erosion of the coolant and for this it is encased in metal cladding generally stainless steel or aluminum. Adequate arrangements should be made for fuel supply, charging or discharging and storing of the fuel.

For economical operation of a nuclear power plant special attention should be paid to reprocess the spent: up (burnt) fuel elements and the unconsumed fuel. The spent up fuel elements are intensively radioactive and emits some neutron and gamma rays and should be handled carefully.

In order to prevent the contamination of the coolant by fission products, a protective coating or cladding must separate the fuel from the coolant stream. Fuel element cladding should possess the following properties :

1. It should be able to withstand high temperature within the reactor.
2. It should have high corrosion resistance.
3. It should have high thermal conductivity.
4. It should not have a tendency to absorb neutrons.
5. It should have sufficient strength to withstand the effect of radiations to which it is subjected.

Uranium oxide (UO_2) is another important fuel element. Uranium oxide has the following advantages over natural uranium:

1. It is more stable than natural uranium.
2. There is no problem or phase change in case of uranium oxide and therefore it can be used for higher temperatures.
3. It does not corrode as easily as natural uranium.
4. It is more compatible with most of the coolants and is not attacked by H_2 , N_2 .
5. There is greater dimensional stability during use.

Uranium oxide possesses following disadvantages :

1. It has low thermal conductivity.
2. It is more brittle than natural uranium and therefore it can break due to thermal stresses.
3. Its enrichment is essential.

Uranium oxide is a brittle ceramic produced as a powder and then sintered to form fuel pellets. Another fuel used in the nuclear reactor is uranium carbide (UC). It is a black ceramic used in the form of pellets.

Table indicates some of the physical properties of nuclear fuels.

Fuel	Thermal conductivity K-cal/m. hr°C	Specific heat kcal/kg °C	Density kg/m ³	Melting point (°C)
Natural uranium	26.3	0.037	19000	1130
Uranium oxide	1.8	0.078	11000	2750
Uranium carbide	20.6	—	13600	2350

10.10.3 MODERATOR

In the chain reaction the neutrons produced are fast moving neutrons. These fast moving neutrons are far less effective in causing the fission of U^{235} and try to escape from the reactor. To improve the utilization of these neutrons their speed is reduced. It is done by colliding them with the nuclei of other material which is lighter, does not capture the neutrons but scatters them. Each such collision causes loss of energy, and the speed of the fast moving neutrons is reduced. Such material is called Moderator. The slow neutrons (Thermal Neutrons) so produced are easily captured by the nuclear fuel and the chain reaction proceeds smoothly. Graphite, heavy water and beryllium are generally used as moderator.

Reactors using enriched uranium do not require moderator. But enriched uranium is costly due to processing needed.

A moderator should possess the following properties :

1. It should have high thermal conductivity.
2. It should be available in large quantities in pure form.
3. It should have high melting point in case of solid moderators and low melting point in case of liquid moderators. Solid moderators should also possess good strength and machinability.
4. It should provide good resistance to corrosion.
5. It should be stable under heat and radiation.
6. It should be able to slow down neutrons.

10.10.4 MODERATING RATIO

To characterize a moderator it is best to use so called moderating ratio which is the ratio of moderating power to the macroscopic neutron capture coefficient. A high value of moderating ratio indicates that the given substance is more suitable for slowing down the neutrons in a reactor. Table 10.3 indicates the moderating ratio for some of the material used as moderator.

Table 10.3

Material	Moderating ratio
Beryllium	160
Carbon	170
Heavy Water	12,000
Ordinary Water	72

This shows that heavy water, carbon and, beryllium are the best moderators

Table 10.4

Moderator	Density (gm/cm ³)
H ₂ O	1
D ₂ O	11
C	1.65
Be	1.85

Table 10.5 shows some of the physical constants of heavy water and ordinary water

Table 10.5

Physical constant	D ₂ O	H ₂ O
Density at 293 K	1.1 gm/cm ³	0.9982 gm/cm ³
Freezing temperature	276.82	273
Boiling temperature	374.5	373 K
Dissociation Constant	0.3×10^{-14}	1×10^{-14}
Dielectric Constant at 293°K	80.5	82
Specific heat at 293°K	1.018	1

Control Rods. The Control and operation of a nuclear reactor is quite different from a fossil and fuelled (coal or oil fired) furnace. The furnace is fed continuously and the heat energy in the furnace is controlled by regulating the fuel feed, and the combustion air whereas a nuclear reactor contains as much fuel as is sufficient to operate a large power plant for some months. The consumption of this fuel and the power level of the reactor depends upon its neutron flux in the reactor core. The energy produced in the reactor due to fission of nuclear fuel during chain reaction is so much that if it is not controlled properly the entire core and surrounding structure may melt and radioactive fission products may come out of the reactor thus making it uninhabitable. This implies that we should have some means to control the power of reactor. This is done by means of control rods.

Control rods in the cylindrical or sheet form are made of boron or cadmium. These rods can be moved in and out of the holes in the reactor core assembly. Their insertion absorbs more neutrons and damps down the reaction and their withdrawal absorbs less neutrons. Thus power of reaction is controlled by shifting control rods which may be done manually or automatically.

Control rods should possess the following properties :

1. They should have adequate heat transfer properties.
2. They should be stable under heat and radiation.
3. They should be corrosion resistant.
4. They should be sufficient strong and should be able to shut down the reactor almost instantly under all conditions.
5. They should have sufficient cross-sectional area for the absorption.

10.10.5 REFLECTOR

The neutrons produced during the fission process will be partly absorbed by the fuel rods, moderator, coolant or structural material etc. Neutrons left unabsorbed will try to leave the reactor core never to return to it and will be lost. Such losses should be minimized. It is done by surrounding the reactor core by a material called reflector which will send the neutrons back into the core. The returned neutrons can then cause more fission and improve the neutrons economy of the reactor. Generally the reflector is made up of graphite and beryllium.

10.10.6 REACTOR VESSEL

It is a strong walled container housing the core of the power reactor. It contains moderator, reflector, thermal shielding and control rods.

10.10.7 BIOLOGICAL SHIELDING

Shielding the radioactive zones in the reactor from possible radiation hazard is essential to protect the operating men from the harmful effects. During fission of nuclear fuel, alpha particles, beta particles, deadly gamma rays and neutrons are produced. Out of these neutrons and gamma rays are of main significance. A protection must be provided against them. Thick layers of lead or concrete are provided round the reactor for stopping the gamma rays. Thick layers of metals or plastics are sufficient to stop the alpha and beta particles.

10.10.8 COOLANT

Coolant flows through and around the reactor core. It is used to transfer the large amount of heat produced in the reactor due to fission of the nuclear fuel during chain reaction. The coolant either transfers its heat to another medium or if the coolant used is water it takes up the heat and gets converted into steam in the reactor which is directly sent to the turbine.

Coolant used should be stable under thermal condition. It should have a low melting point and high boiling point. It should not corrode the material with which it comes in contact. The coolant should have high heat transfer coefficient. The radioactivity induced in coolant by the neutrons bombardment should be nil. The various fluids used as coolant are water (light water or heavy water), gas (Air, CO₂, Hydrogen, Helium) and liquid metals such as sodium or mixture of sodium and potassium and inorganic and organic fluids.

Power required to pump the coolant should be minimum. A coolant of greater density and higher specific heat demands less pumping power and water satisfies this condition to a great extent. Water is a good coolant as it is available in large quantities can be easily handled, provides some lubrication also and offers no unusual corrosion problems. But due to its low boiling point (212 F at atmospheric pressure) it is to be kept under high pressure to keep it in the liquid state to achieve a high heat transfer efficiency. Water when used as coolant should be free from impurities otherwise the impurities may become radioactive and handling of water will be difficult.

10.10.9 COOLANT CYCLES

The coolant while circulating through the reactor passages takes up heat produced due to chain reaction and transfers this heat to the feed water in three ways as follows :

- (a) *Direct Cycle.* In this system coolant which is water leaves the reactor in the form of steam. Boiling water reactor uses this system.
- (b) *Single Circuit System.* In this system the coolant transfers the heat to the feed water in the steam generator. This system is used in pressurized reactor.
- (c) *Double Circuit System.* In this system two coolants are used. Primary coolant after circulating through the reactor flows through the intermediate heat exchanger (IHX) and passes on its heat to the secondary coolant which transfers its heat to the feed water in the steam generator. This system is used in sodium graphite reactor and fast breeder reactor.

10.10.10 REACTOR CORE

Reactor core consists of fuel rods, moderator and space through which the coolant flows.

The most widespread power plant reactor types are:

1. Pressurized Water Reactor (PWR)
2. Boiling Water Reactor (BWR)
3. Pressurized Heavy Water Reactors (PHWR)
4. Liquid Metal Fast Breeder Reactors (LMFBR)
5. High Temperature Gas Cooled Reactors (HTGR)
6. Advanced Gas Cooled Reactors (AGR)
7. Magnox
8. Advanced Pressurized Water Reactor (APWR)
9. Advanced Liquid Metal Reactor (ALMR)
10. Advanced Boiling Water Reactor (ABWR)
11. Integral Fast Reactor (IFR)
12. Modular High Temperature Gas Cooled Reactor (MHTGR)
13. Simplified Boiling Water Reactor (SBWR)

Few of above reactors are explained in the following sections.

Pressurized Water Reactor (PWR)

Nuclear power plants run on uranium fuel. In the reactor, uranium atoms are split through a process known as fission. When atoms are split, they produce a large amount of energy that is then converted to heat. The heat boils water, creating steam that is used to turn turbines, which spins the shaft of a generator. Inside the generator, coils of wire spin in a magnetic field and electricity is produced. The Nuclear power plants use two types of reactors to achieve this process boiling water reactors (BWR) and pressurized water reactors (PWR).

The pressurized water reactor belongs to the light water type the moderator and coolant are both light water (H_2O). The cooling water circulates in two loops, which are fully separated from one another. Pressurized Water Reactors (PWR) keep water under pressure, so the water heats but does not boil even at the high operating temperature (Figure 3.8).

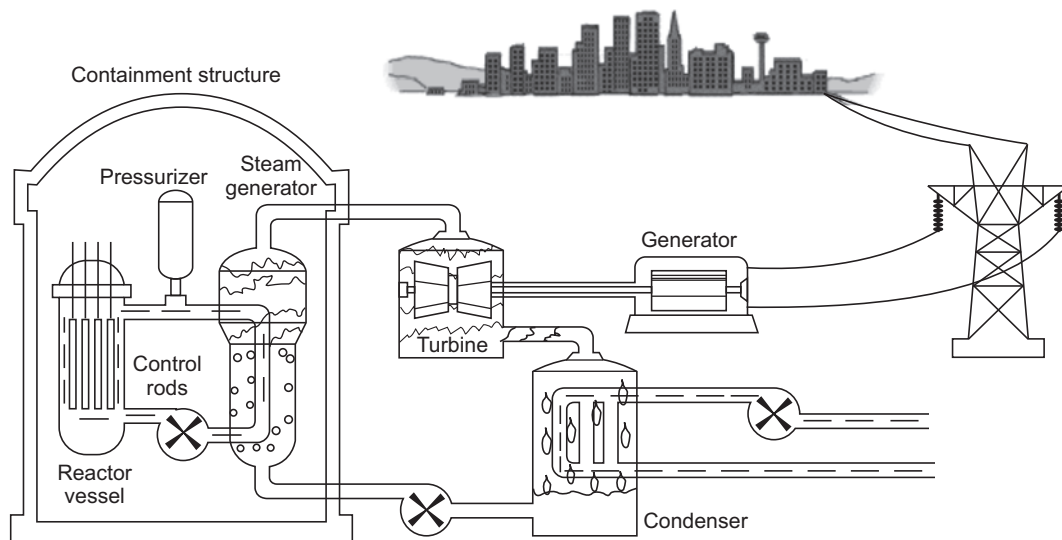

Fig. 3.8. The Pressurized Water Reactor

Constant pressure is ensured with the aid of the pressurizer. If pressure falls in the primary circuit, water in the pressurizers is heated up by electric heaters, thus raising the pressure. If pressure increases, colder cooling water is injected to the pressurizer. Since the upper part is steam, pressure will drop. The primary circuit water transferred its heat to the secondary circuit water in the small tubes of the steam generator; it cools down and returns to the reactor vessel at a lower temperature.

Since the secondary circuit pressure is much lower than that of the primary circuit, the secondary circuit water in the steam generator starts to boil. The steam goes from here to the turbine, which has high and low pressure stages. When steam leaves the turbine, it becomes liquid again in the condenser, from where it is pumped back to the steam generator after pre-heating.

Normally, primary and secondary circuit waters cannot mix. In this way, it can be achieved that any potentially radioactive material that gets into the primary water should stay in the primary loop and cannot get into the turbine and condenser. This is a barrier to prevent radioactive contamination from getting out.

In pressurized water reactors the fuel is usually low (3 to 4 percent) enriched uranium oxide, sometimes uranium and plutonium oxide mixture (MOX). In today's PWRs the primary pressure is usually 12 to 16 bars, while the outlet temperature of coolant is 30 to 32°C. PWR is the most widespread reactor type in the world they give about 64% of the total power of the presently operating nuclear power plants.

Boiling Water Reactor (BWR)

Boiling Water Reactors (BWR) heat water by generating heat from fission in the reactor vessel to boil water and create steam, which turns the generator. In both types of plants, the steam is turned back into water and can be used again in the process.

In a boiling water reactor, light water (H_2O) plays the role of moderator and coolant as well. Part of the water boils away in the reactor pressure vessel, thus a mixture of water and steam leaves the reactor core (Figure 3.9).

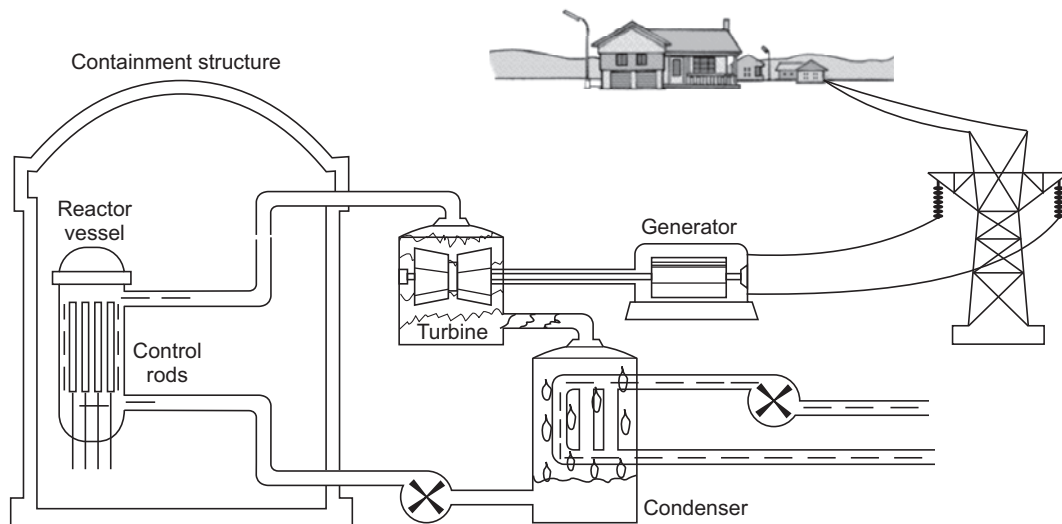

Fig. 3.9. The Boiling Water Reactor (BWR)

The so generated steam directly goes to the turbine, therefore steam and moisture must be separated. Steam leaving the turbine is condensed in the condenser and then fed back to the reactor after preheating.

Water that has not evaporated in the reactor vessel accumulates at the bottom of the vessel and mixes with the pumped back feed water.

Since boiling in the reactor is allowed, the pressure is lower than that of the PWRs. It is about 6 to 7 bars. The fuel is usually uranium dioxide. Enrichment of the fresh fuel is normally somewhat lower than that in a PWR.

The advantage of this type is that - since this type has the simplest construction - the building costs are comparatively low. 22.5% of the total power of presently operating nuclear power plants is given by BWRs.

10.18 COMPARISON OF NUCLEAR POWER PLANT AND STEAM POWER PLANT

The cost of electricity generation is nearly equal in both these power plants. The other advantages and disadvantages are as follows :

(i) The number of workman required for the operation of nuclear power plant is much less than a steam power plant. This reduces the cost of operation.

(ii) The capital cost of nuclear power plant falls sharply if the size of plant is increased. The capital cost as structural materials, piping, storage mechanism etc. much less in nuclear power plant than similar expenditure of steam power plant. However, the expenditure of nuclear reactor and building complex is much higher.

(iii) The cost of power generation by nuclear power plant becomes competitive with cost of steam power plant above the unit size of about 500 mW.

5.15 Waste Disposal

Waste disposal problem is common in every industry. Wastes from atomic energy installations are radioactive, create radioactive hazard and require strong control to ensure that radioactivity is not released into the atmosphere to avoid atmospheric pollution.

The wastes produced in a nuclear power plant may be in the form of liquid, gas or solid and each is treated in a different manner:

Liquid Wastes. The disposal of liquid wastes is done in two ways :

(i) *Dilution.* The liquid wastes are diluted with large quantities of water and then released into the ground. This method suffers from the drawback that there is a chance of contamination of underground water if the dilution factor is not adequate.

(ii) *Concentration to small volumes and storage.* When the dilution of radioactive liquid wastes is not desirable due to amount or nature of isotopes, the liquid wastes are concentrated to small volumes and stored in underground tanks. The tanks should be of assured long term strength and leakage of liquid from the tanks should not take place otherwise leakage or contents, from the tanks may lead to significant underground water contamination.

Gaseous Wastes. Gaseous wastes can most easily result in atmospheric pollution. Gaseous wastes are generally diluted with air, passed through filters and then released to atmosphere through large stacks (chimneys).

Solid Wastes. Solid wastes consist of scrap material or discarded objects contaminated with radioactive matter. These wastes if combustible are burnt and the radioactive matter is mixed with concrete, drummed and shipped for burial. Non-combustible solid wastes, are always buried deep in the ground.

5.16 Homogeneous Reactor

Fig. 5.16 shows a Homogeneous Aqueous Reactor (H.A.R.). In this type of reactor water is used as coolant and moderator. It makes use of a fertile and fissionable material which circulate with a soluble fissile U^{235} fuel in a homogeneous and slurry form. The moderator and the coolant side is provided by the other fluid. The advantage of this reactor is that problems associated with solid wastes are eliminated. Heavy water is used as moderator and coolant. It is more costly than ordinary water. The disad-

16.8.2 Radioactive Waste Disposal

One of the major problems in the nuclear plants is the disposal of waste products that are highly radioactive. They emit large quantities of γ rays and these high-energy γ rays destroy all living matter through which they pass.

The radioactive products of 400 MW power station would be equivalent to 100 tons of radium daily and the radioactive effect of these plant products if exposed to atmosphere would kill all the living organisms within an area about 100 square miles.

The disposal of nuclear waste is a very difficult problem for the engineers and scientists.

In a nuclear fuel cycle, the solid, liquid and gaseous radioactive wastes are produced at different stages. These radioactive wastes must be disposed off in such a manner that there is no hazard to human and plant life. Moderate active solid wastes are buried in the ground. Moderate liquid wastes after preliminary treatments are discharged in deep pits or dry wells to keep them from seeping out into the surrounding ground. Active liquids are kept in concrete tanks and these tanks are buried in the ground till the radioactivity decays. Many times the radioactivity increases the temperature of the liquid waste or sometimes these liquids boil and the activity decreases with time. Gaseous wastes are discharged to atmosphere through high stacks if the wind permits.

The waste is disposed to air, ground and ocean.

1. Air

There are a lot of issues in the disposal of radioactive gases into the air. Because strong radioactive gases such as strontium and iodine are absorbed by the plants and they enter into the human body through food. Caesium is absorbed in muscle and strontium is absorbed in bones resulting in paralyses of the body. Generally, radioactive gases are collected and stored in a tank buried in the ground and disposed off to the atmosphere when radioactivity level is sufficiently low.

The amount of radioactivity presently disposed off in the air is well below the harmful level, but the problem will become serious when a large number of power reactors come up in operation.

2. Ground

This is one of the easy and cheapest methods of disposal because soil absorbs radioactive material easily. This disposal is suitable mostly in areas of low rainfall that are high above the ground water level.

Most of the radioactivities of waste are removed just by storage. The storage problem is simplified by separating caesium and strontium, which are extremely radioactive. These are generally stored in tanks that are buried in ground and then disposed off into the sea after 13 years of storage.

Defunct coal mines are used for waste disposal. The wastes are disposed off in salt heaps provided in the mines, because salt is a powerful absorber of radioactive emissions. Disposing off liquid waste by freezing is an easy and more economical method.

Disposal of LLW: The final deposition of the wastes is a major concern. Many countries are undertaking activities involving underground disposal in deep geological formations. These countries are investigating suitable sites and suitable methods of storage at these sites. These methods must be efficient enough to protect present and future populations from potential hazards. The suitable sites must be free of flowing ground water, but storage vessels must demonstrate reliability even in flowing water conditions.

The disposal of low and intermediate level wastes is done at relatively shallow depths in many countries, namely packing the waste in solid form in concrete steel drums and burying (Figure 16.34).

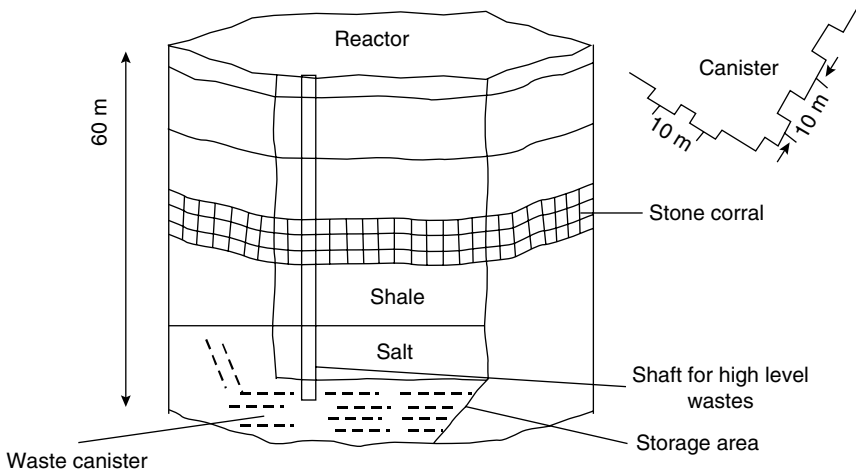

Fig. 16.34 Disposal of LLW

If spent fuel is to be disposed, it is buried in the earth, namely deep salt or granite formations below ground or below the sea bed.

Figure 16.35 shows a conceptual depository for the storage of HLW in rock salt formation for thousands of years. The solidified waste is placed in canisters that are stored in holes drilled in rock salt with a spacing of 10 m to allow efficient dissipation of energy without exceeding the temperature limits of either canister or salt. Each canister requires 100 m² of salt for cooling.

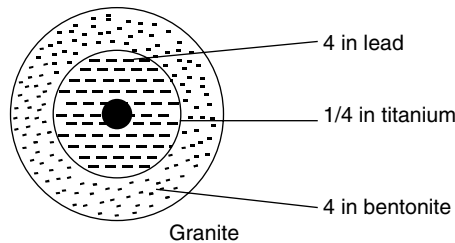

Fig. 16.35 Canister for Vitrified High-Level Waste

3. Ocean

In many places, the liquid waste is disposed off to the sea through the pipes carried from the plant to the point of disposal. While disposing off the waste into the sea, it should be ensured that the radioactivity level should not be very harmful to the fish life and seaweed, which is harvested for human use. In another method, the solid wastes should be cased into concrete

blocks and these should be dropped into the sea at suitable places. The cost of disposal by this method is approximately ₹300 per cubic metre volume.

The danger of disposal into the sea water is indirect and depends on the absorption of radioactive elements such as caesium and strontium by plankton and then through the biological chain to the edible fishes and then to humans.

It is necessary to keep the radioactive solid waste at a depth of 6 m in water nearly for 100 days. It was found that after 100 days cooling of radioactive waste of 28 MW plant in water still had a radioactivity equal to million grams of radium. About 50 per cent of the radioactive elements disappear during cooling.

16.8.2.1 Different Methods for Nuclear Waste Disposal

In this section, different types of nuclear wastes and the methods used to handle them are discussed. These are as follows:

1. Fission fragments → weak, intensity active; isotopes → spent fuel stored under 6 m deep water to cool (100 days) → intensely active
2. Radioactive waste – gaseous liquid, solid
 - Solid → buried at depths of few metres
 - Gaseous → discharged to atmosphere through high stacks
 - Liquid → after preliminary treatment discharged in dry wells or deep pits
3. Waste solution → stored in a stainless steel tank enclosed in a concrete wall, buried under earth (10 m) and provided with cooling oil to keep temperature at 50°C
4. Low-level solid waste → cast in cement in steel drum → drums buried below soil or kept at the bed of ocean
5. Medium-level solid waste → incorporated into cement cylinders
6. High-level liquid waste → stored in special steel tanks in concrete walls, water cooled → taken to storage area and disposed within 10 cm thick lead wall surrounded by 6 mm titanium. Some other locations and methods used for nuclear waste disposal are as follows:

(i) Geological formations

(a) Rock salt

- Powerful absorber of radioactive emission
- Good thermal conductivity
- Cavities and tunnels can be easily made

(b) Argillaceous sediments – boreholes are provided at 160–260 m depths in a 100-m thick bed of clay

(c) Hard rocks – igneous, metamorphic, sedimentary rocks

(ii) Ocean

Floors of deep ocean provide safe, potential disposal sites for solidified high-level radioactive waste

(iii) New methods to treat HLW

- (a) HARVEST Process – (highly active residues vitrification engineering study). This process was developed in 1970. In this process, highly active liquid waste is mixed with

glass forming chemical in a steel container. The container is heated in a furnace to about 1000°C. It involves the following process. This mixture fuses to glass, which is further cooled, sealed and then discharged to the storage area (Figure 16.36).

Liquid waste + glass-forming material → heated steel vessel



Mixture fuses to glass



Cooled, sealed, discharged to storage

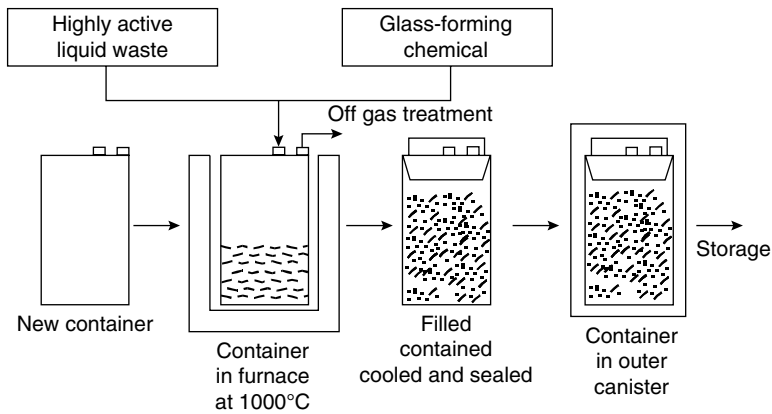

Fig. 16.36 Waste Treatment (HARVEST Process)

(b) AVM (*Atelier de Vitrification Marcoule*) Process

Figure 16.37 shows AVM (*Atelier de Vitrification Marcoule*) process used for liquid waste disposal. The process is self-explanatory. In this process, the liquid waste fed to a container is heated in a furnace and further mixed with glass powder. The mixture that comes out is melted in a melting furnace and collected in a vessel. In the subsequent steps, the container is closed and the exterior body of the vessel is decontaminated before disposing off into the storage area.

(iv) Nuclear waste calcining

Liquid → solid means small volume and easy storage. Calcining the liquid waste results in free flowing non-corrosion granules.

Features

- Spent fuel is reduced to a liquid
- Extraction of usable fuel from liquid
- Calcining the liquid waste

Off-gas clean-up system

Figure 16.38 shows an off-gas clean up system. Hot gas is quenched and passed through scrubbers and dried in condensers, demisters. It is then reheated and passed through silica gel

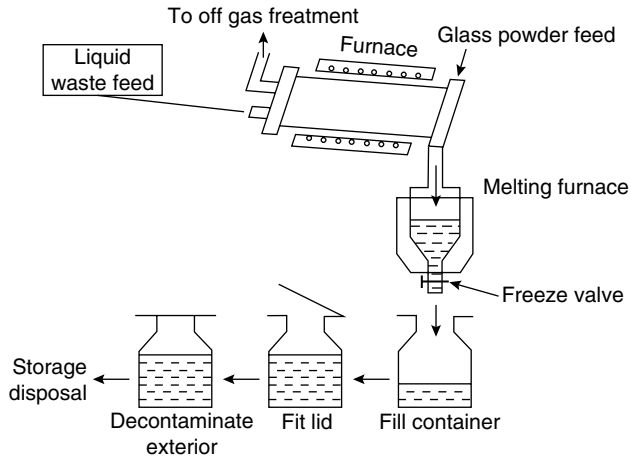

Fig. 16.37 AVM Process

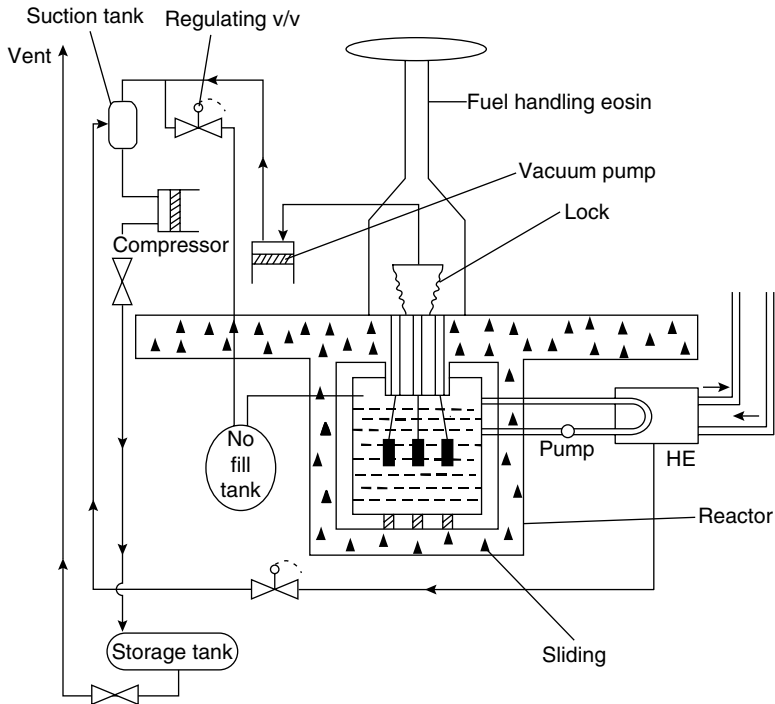

Fig. 16.38 Off-Gas Clean-Up System

absorber, demisters, filters, atmosphere protection system and then discharged to atmosphere through a stack 80 m high.

Gas disposal system – krypton, iodine gases, tritium, CO₂

Krypton – cryogenic treatment of dissolved off-gas stream, packed in gas cylinder under pressure

Iodine – caustic scrubbing or HNO_3 scrubbing

Tritium – volatilization, pyrochemical processing, isotope enrichment

CO_2 – Caustic scrubbing

8.4 ADVANTAGE OF DIESEL POWER PLANT

The advantages of diesel power plants are listed below.

1. Very simple design also simple installation.
2. Limited cooling water requirement.
3. Standby losses are less as compared to other Power plants.
4. Low fuel cost.
5. Quickly started and put on load.
6. Smaller storage is needed for the fuel.
7. Layout of power plant is quite simple.
8. There is no problem of ash handling.
9. Less supervision required.
10. For small capacity, diesel power plant is more efficient as compared to steam power plant.
11. They can respond to varying loads without any difficulty.

8.5 DISADVANTAGE OF DIESEL POWER PLANT

The disadvantages of diesel power plants are listed below.

1. High Maintenance and operating cost.
2. Fuel cost is more, since in India diesel is costly.
3. The plant cost per kW is comparatively more.
4. The life of diesel power plant is small due to high maintenance.
5. Noise is a serious problem in diesel power plant.
6. Diesel power plant cannot be constructed for large scale.



13.4 PLANT LAYOUT WITH AUXILIARIES

Figure 13.6 show general layout of a Diesel Engine plant. The essential components of (diesel engine plant) are

1. *Engine*: It is the main component that develops required power. The engine is directly coupled to the generator.
2. *Air filter and supercharger*: Air filter removes the dust from the air before it enters the engine. Supercharger increases the pressure of air at engine inlet and hence increases engine power. They are usually driven by the engines.

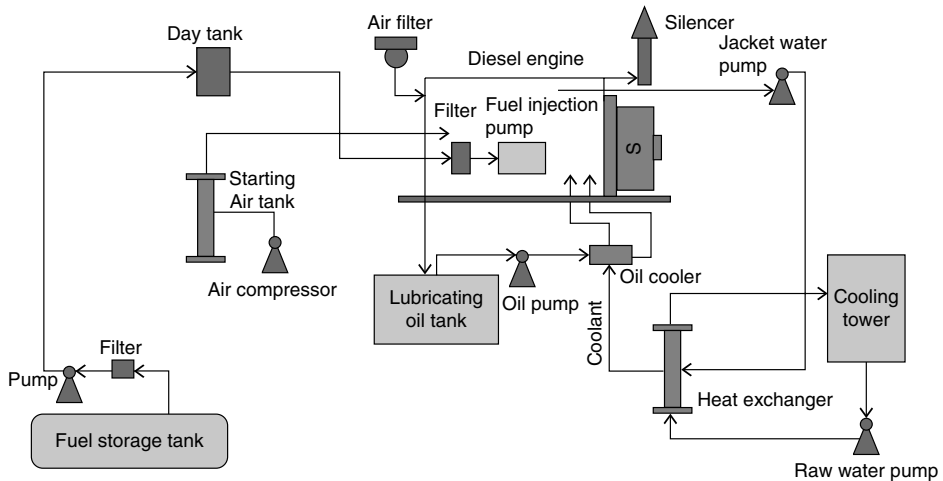

Fig. 13.6 General Layout of DG Plant

3. *Exhaust system:* The system includes silencers and connecting ducts. As the exhaust gases have higher temperatures, heat of exhaust gases is utilized for heating the oil or air supplied to the engine.
4. *Fuel system:* It contains the storage tank, fuel pump, fuel transfer pump, oil strainers and heaters. The amount of fuel supplied depends on the load on the plant.
5. *Cooling system:* The system includes water circulating pumps, cooling towers or spray ponds and water filtration or treatment plant. The purpose of cooling system is to ensure the life of the cylinder by extracting the heat developed from the engine cylinder walls and hence keeping the temperature within the safer range.
6. *Lubrication system:* The system includes oil pumps, oil tanks coolers and connecting pipes. The system reduces friction between the moving parts and hence reduces wear and tear.
7. *Starting system:* The system includes starting aides such as compressed air tanks. The tank supplies compressed air to start the engine from cold.
8. *Governing system:* The governing engine maintains constant speed of the engine irrespective of load on the plant. This is done by varying the fuel supplied to the engine.

13.5 FUEL SUPPLY SYSTEM

Diesel engine fuel injection systems can be divided into two basic types:

1. Air injection

In this system, the fuel valve is connected to a high-pressure air line fed by a multistage air compressor driven by the engine. The pressure of air may be about 60–70 bar. The blast air sweeps the fuel along with it when the fuel valve is opened. Thus, a well-atomized fuel spray is sent to the combustion chamber.

2. Solid injection

In this system, fuel is directly injected into the combustion chamber without primary atomization. The method is also known as *airless mechanical injection*. The system consists of a pressurizing unit (fuel pump) and an atomizing unit (fuel injector). The high-pressure diesel is sprayed into the engine cylinder by the fuel injector.

Figure 13.7 shows the sectional view of Bosch fuel injection pump. It consists of a *barrel* with reciprocating *plunger* inside it driven by a camshaft. The plunger has a constant stroke and is single acting. A very small clearance of about two to three thousandths of a millimetre is provided between the pump barrel and the plunger. This arrangement provides a perfect sealing without any leakage even at very high pressures and low speeds. The pump barrel has two radially opposing ports known as *inlet port* and *spill port* or bypass port. A vertical channel extending from the top of the plunger to an annual helical groove is provided on the upper part of the plunger. It varies the quantity of fuel delivered per stroke. The top edge of the upper end is milled in the form of a helix. A spring-loaded delivery valve is provided at the top of the barrel. The position of the helical groove with respect to the spill port is changed by rotating the plunger with the *rack* or control rod. By moving the rack, the quantity of fuel injected can be varied from zero to that demanded at full load.

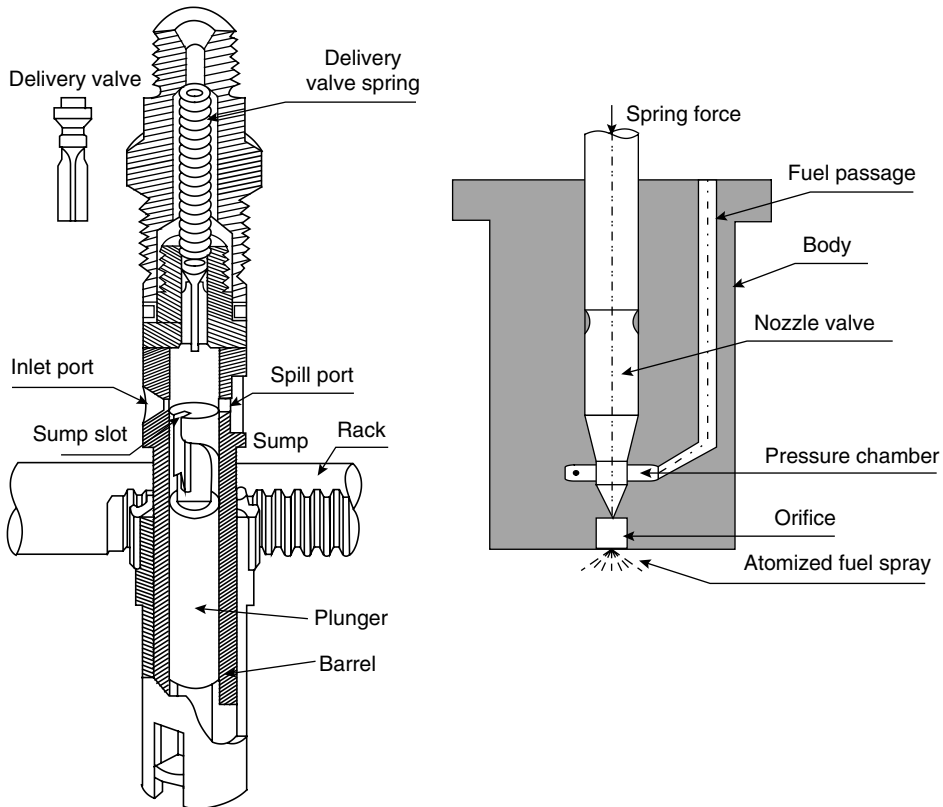

Fig. 13.7 Bosch Fuel Injection Pump

3. Operation

During the delivery stroke, a cam raises the plunger upwards and a plunger return spring brings it back to BDC position. When the plunger is at the bottom of its stroke, fuel starts flowing into the barrel through the inlet port. Fuel fills the space above the plunger in the vertical groove and in the space between the helix.

When the plunger starts moving upwards, some amount of fuel enters the barrel as the inlet ports are uncovered. Further movement of the plunger upwards covers both the inlet and spill ports and the trapped fuel gets compressed. Due to high pressure, fuel is forced through the delivery valve and enters the injector which injects fuel into the combustion chamber. The injection process continues till the end of the upward stroke and stops when the lower end of the helix uncovers the spill port. As soon as spill port uncovers, the fuel pressure in the barrel drops suddenly due to the flow of fuel back to the suction chamber through the vertical channel. Injection process ends as both spring-loaded injector valve and spring-loaded delivery valve are suddenly closed. Plunger movement controls the quantity of oil delivered.

Figure 13.8 shows a typical fuel system used in diesel plants. The fuel oil may be delivered at the plant site by trucks, railroad tank cars or barge and tankers. From tank truck, the delivery is done using the unloading facility to main storage tanks. This fuel is then transferred by pumps to small service storage tanks known as *engine day tanks*. The main flow is ensured by arranging the piping equipment with the necessary heaters, by passes, shut offs, drain lines, relief valves, strainers and filters, flow meters and temperature indicators. The actual flow depends on type of fuel, engine equipment, size of the plant, etc. The tanks should contain manholes for internal access and repair, fill lines to receive oil, vent lines to discharge vapours, overflow return lines for controlling oil flow and a suction line to withdraw oil. Coils heated by hot water or steam reduce oil viscosity, which lower pumping power needs.

The minimum storage capacity of at least a month's requirement of oil is generally kept in bulk. However, when the advantages of seasonal fluctuations in cost of oil are to be availed, it may be necessary to provide storage for a few months' requirements. Day tanks supply the daily fuel needs of engines and are placed at a height so that oil may flow to engines under gravity.

The fuel oil supply system operation would be satisfactory if the following points are taken care of:

- (i) Provisions for cleanliness and for changing over of lines during emergencies.
- (ii) Provisions for tight pipe joints in all suction lines.
- (iii) Keep all oil lines under air pressure with the joints tested with soap solution. Small air leaks into the line can be the source of operating difficulties and are hard to rectify once the plant is in operation.
- (iv) Flush the piping between filter and the engine thoroughly by oil before being first placed in service.
- (v) Due importance should be given for cleanliness in handling bulk fuel oil. Dirt particles will ruin lap of injection pumps or plug the injection nozzle orifices. Thus, high-grade filters are of great importance to the diesel oil supply system.

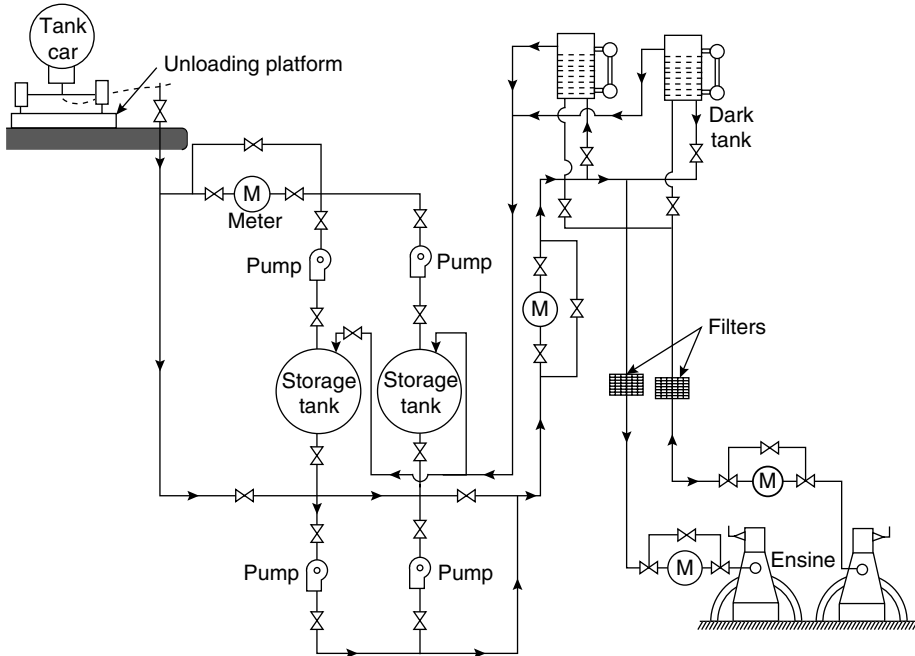
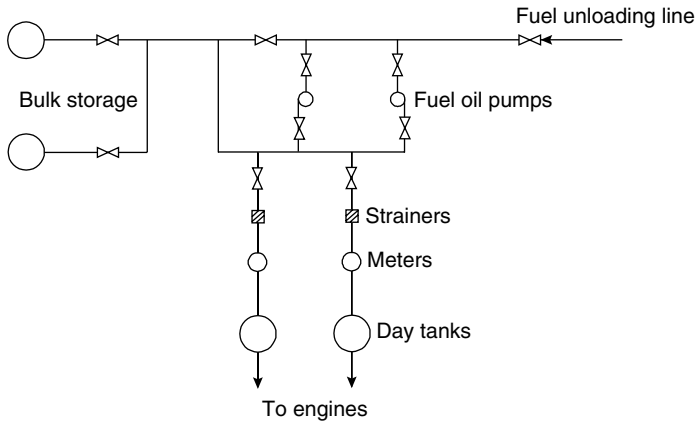

Fig. 13.8 System of Fuel Storage for a Diesel Power Plant

13.5.1 Fuel Injection System

Fuel injection system is the heart of the diesel engine. In an injection system, very small quantity of fuel must be measured out, injected, atomized and mixed with combustion air. The mixing problem becomes more difficult, the larger the cylinder and faster the rotational speed.

However, special combustion arrangements such as pre-combustion chambers, air cells, etc., are necessary to ensure good mixing. Engines driving electrical generators have lower speeds and simple combustion chambers.

Functions of a fuel injection system are as follows:

- (i) Filter the fuel
- (ii) Meter or measure the correct quantity of fuel to be injected
- (iii) Properly time the fuel injection
- (iv) Control the rate of fuel injection
- (v) Atomize or break-up the fuel into fine particles
- (vi) Properly distribute the fuel in the combustion chamber

The injection systems especially the parts that are actually manufactured with great accuracy meter and inject the fuel. Some of the tolerances between the moving parts are so small (of the order of $1\ \mu$) that they require special attention during manufacture. Hence, the injection systems are costly.

13.5.2 Types of Fuel Injection Systems

Most commonly used fuel injection systems in diesel power station are as follows:

- (i) Common rail injection system
- (ii) Individual pump injection system
- (iii) Distributor

Atomization of fuel oil can be done by (i) air blast and (ii) pressure spray. In the olden days, engines used air fuel injection at about 70 bar, which was sufficient not only to inject the oil, but also to atomize it for a rapid and thorough combustion. The expense of providing an air compressor and tank led to the development of ‘solid’ injection, using liquid pressure of between 100 and 200 bar, which is sufficiently high to atomize the oil it forces through spray nozzles.

1. Common rail injection system

Two types of common rail injection systems are shown in Figure 13.9 and 13.10, respectively.

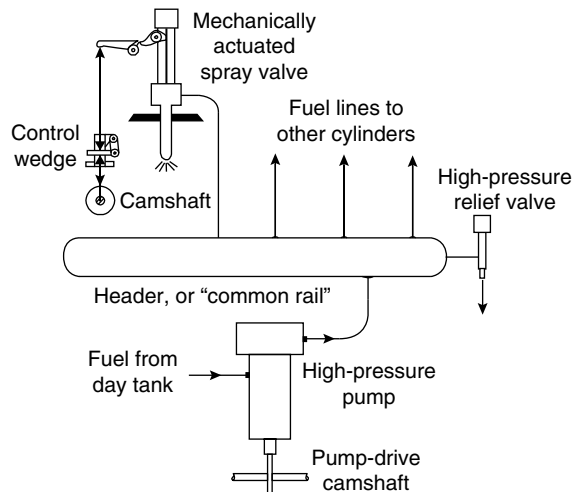

Fig. 13.9 Common Rail Injection System Using a Single Pump

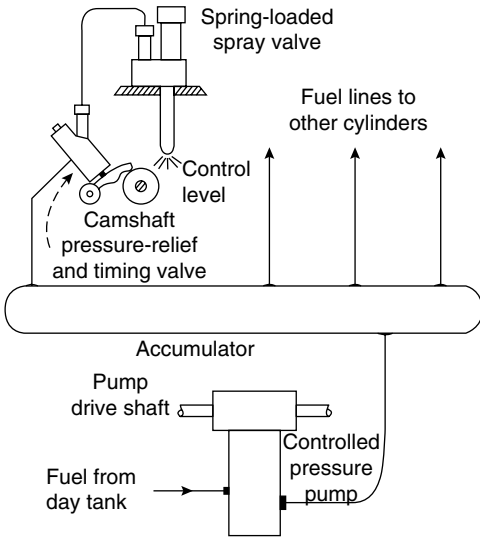

Fig. 13.10 *Controlled Pressure System*

In this case, a single pump supplies high-pressure fuel to header. A relief valve holds pressure constant. The control wedge adjusts the lift of mechanical operated valve to set the amount and time of injection.

Figure 13.10 shows a controlled pressure system. It has a pump that maintains set head pressure. Pressure relief and timing valves regulate injection time and amount. Spring-loaded spray valve acts merely as a check.

2. Individual pump injection system

An individual pump injection system is shown in Figure 13.11. In this system, an individual pump cylinder connects directly to each fuel nozzle. Pump meters charge and control injection timing. Nozzles contain a delivery valve that is actuated by the fuel oil pressure.

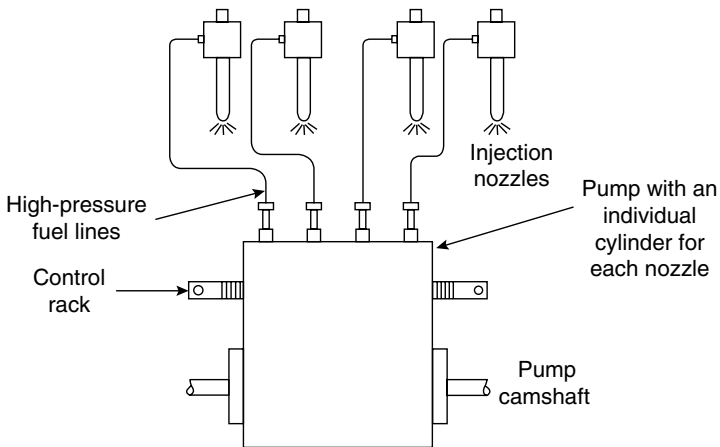

Fig. 13.11 *Individual Pump Injection System*

3. Distributor system

Most commonly used distributor system is shown in Figure 13.12. In this system, the fuel is metered at a central point. A pump pressurizes, meters the fuel and times the injection. The fuel is then distributed to cylinders in correct firing order by cam-operated poppet valves that open to admit fuel to the nozzles.

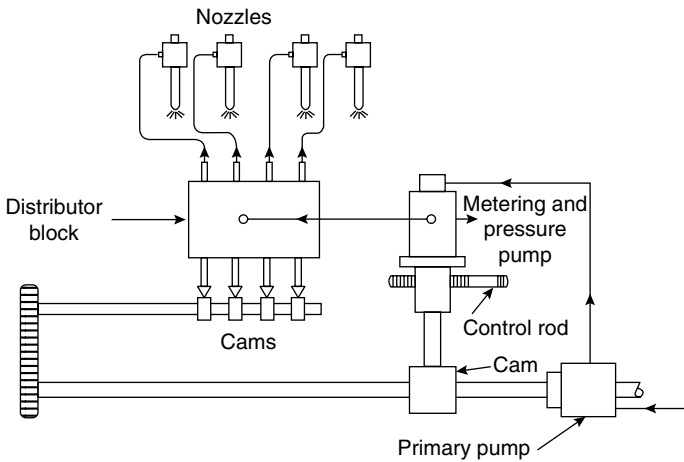

Fig. 13.12 Distributor System

13.6 SUPER CHARGING

It is well known that the power output of an engine increases with an increase in amount of air in the cylinder at the beginning of compression stroke. This is because air allows burning more quantity of fuel. Supercharging is a process that helps to increase the suction pressure of the engine above atmospheric pressure and the equipment used for this purpose is known as supercharger.

The advantages of supercharged engines are as follows:

- (i) *Power increase:* By supercharging the engine, the engine output can be increased by 30–50 per cent at the same speed of the engine.
- (ii) *Fuel economy:* The combustion in supercharged engine is better as it provides better mixing of the air and fuel than un-supercharged engine. Hence, the specific fuel consumption of a supercharged engine is less than a natural aspirated engine. The thermal efficiency of a supercharged engine is also higher.
- (iii) *Mechanical efficiency:* The mechanical efficiency of a supercharged engine is better than a natural aspirated engine at the same speed. This is because the power increase due to supercharging increases faster than the rate of increase in friction losses.
- (iv) *Scavenging:* With the increase in supercharged pressure, the scavenging action is better in two-stroke supercharged engines as compared to naturally aspirated engines, because the quantity of residual gases is reduced.
- (v) *Knocking:* Supercharging reduces the possibility of knocking in diesel engines because delay period is reduced with an increase in supercharged pressure. Actually, supercharging results in smoother running of the engine. It has been found that four-stroke engines are more easily adaptable to supercharging than two-stroke engines.

Due to the number of advantages of supercharging mentioned above, modern diesel engines used in diesel plant are generally supercharged. By supercharging, the size of the engine is

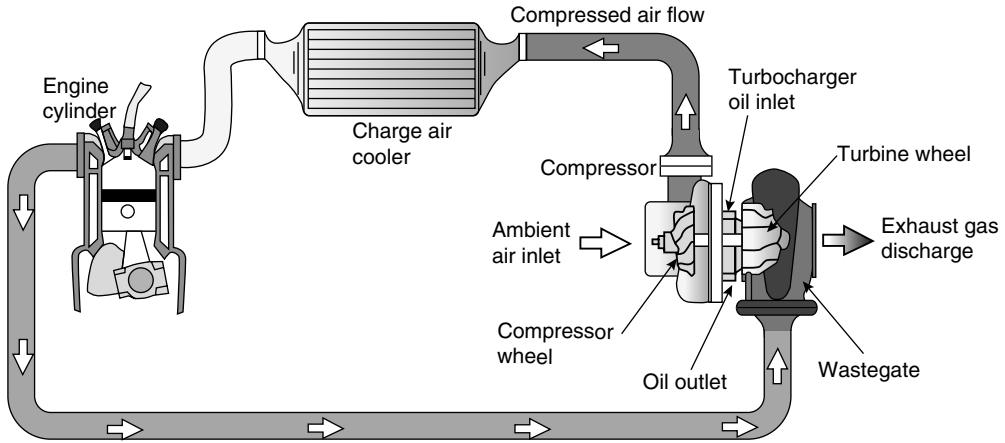

Fig. 13.13 Working of a Turbo-Charged Engine

reduced for a given output and consequently the space requirements and civil engineering works also reduced.

The Superchargers that are considered for diesel power plants are positive displacement type, centrifugal type and exhaust turbocharger. The selection depends upon its relative merits for a particular situation. Figure 13.13 shows a typical turbocharged engine.

A turbocharger is used to force air/fuel mixture into an engine at a pressure greater than the natural atmospheric pressure. The exhaust coming out of the engine is pushed through a turbine, mounted on a shaft, which in turn spins an air compressor. The compressor draws air in and blows it into the inlet manifold, and generates the boost. Forcing the air/fuel mixture into an engine allows it to burn more fuel and generate more power without changing engine capacity. When the air is compressed (with a turbo) it gets hotter. As hotter air contains less oxygen than cooler air, less oxygen is available to burn extra fuel going into the engine.

13.7 METHOD OF STARTING DIESEL ENGINES

The SI engines used for power generation in DG plants are usually small in size, which use compression ratio from 7 to 11. Hand and electric motor (6–12V, DC) cranking are generally used to start the engine.

The CI engines use very high compression ratios from 20 to 22 and hence it is difficult to hand crank the engine. Hence, some mechanical cranking systems are used.

1. Compressed air system

In this system, shown in Figure 13.14, air at a pressure of 20–30 bar is supplied from an air tank at the engine inlet through intake manifold. In the case of multi-cylinder engine, compressed air enters one or more of the engine cylinders and forces down the piston to turn the engine shaft. During the meantime, suction stroke of some other cylinder takes place and the compressed air pushes this cylinder and causes the engine shaft to rotate. Gradually the engine gains momentum and by supplying the fuel engine starts running.

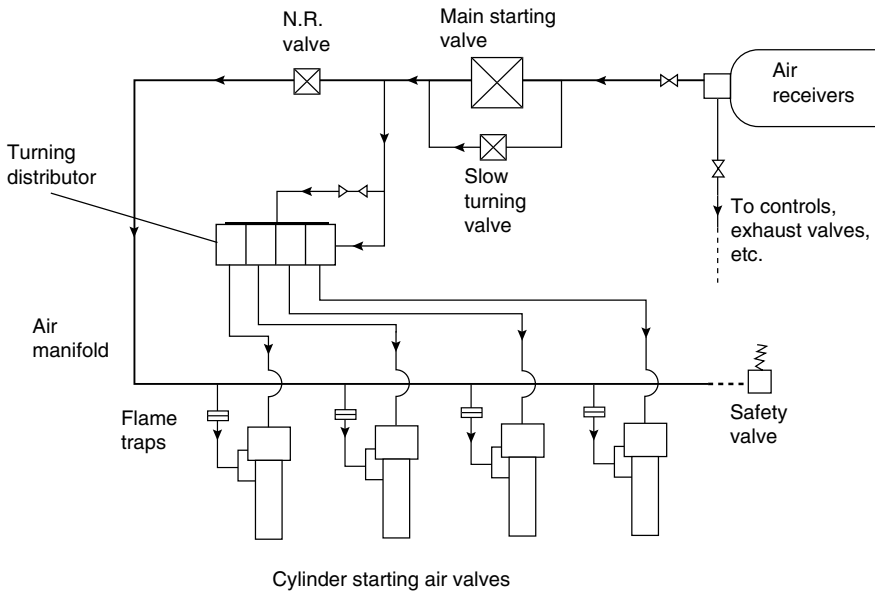

Fig. 13.14 *Compressed Air System*

2. *Electric starting*

An electric starting system is shown in Figure 13.15. It consists of an electric motor driving a pinion, which engages a toothed rim on engine flywheel. Electric supply for the motor is made using a small electric generator driven by the engine. A storage battery of 12–36 V is used to supply power to the electric motor. The electric motor disengages automatically after the engine has started.

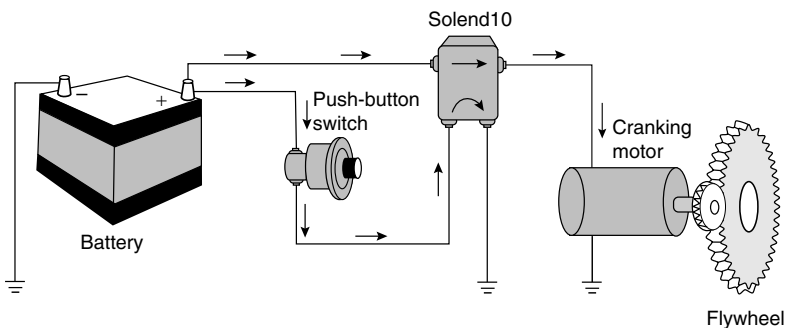

Fig. 13.15 *Electric Starting System*

The starting motor for diesel and gasoline engines operates on the same principle as a direct current electric motor. The motor is designed to carry extremely heavy loads but, because it draws a high current (300–665 A), it tends to overheat quickly. To avoid overheating, the motor

should not be run for more than the specified amount of time, usually 30 seconds. A time lag of 2 or 3 min is essential before using it again. The starting motor is located near the flywheel. When the starting switch is closed, the drive gear on the starter meshes with the teeth on the flywheel. The drive mechanism (1) transmits the turning power to the engine when the starting motor runs, (2) disconnects the starting motor from the engine immediately after the engine has started and (3) provides a gear reduction ratio between the starting motor and the engine. The drive mechanism disengages the pinion from the flywheel immediately after the engine starts to avoid any damage, since this engaged position may increase the motor shaft speed to 22,500–30,000 rpm as against the engine speed of 1500 rpm.

3. Hydraulic starting systems

Several types of hydraulic starting systems are in use for engines. A typical hydraulic starting system is shown in Figure 13.16. In general most systems consist of a hydraulic starting motor, a piston-type accumulator, a manually operated hydraulic pump, an engine-driven hydraulic pump and a reservoir for the hydraulic fluid. Hydraulic pressure is provided in the accumulator by a manually operated hand pump or from the engine-driven pump when the engine is operating. By operating the starting lever, the control valve allows hydraulic oil (under pressure of nitrogen gas) from the accumulator to pass through the hydraulic starting motor, and cranks the engine. When the starting lever is released, spring action disengages the starting pinion and closes the control valve. This stops the flow of hydraulic oil from the accumulator. To protect the starter from the high speeds of the engine, an overrunning clutch is used. The hydraulic starting system is used on some smaller diesel engines.

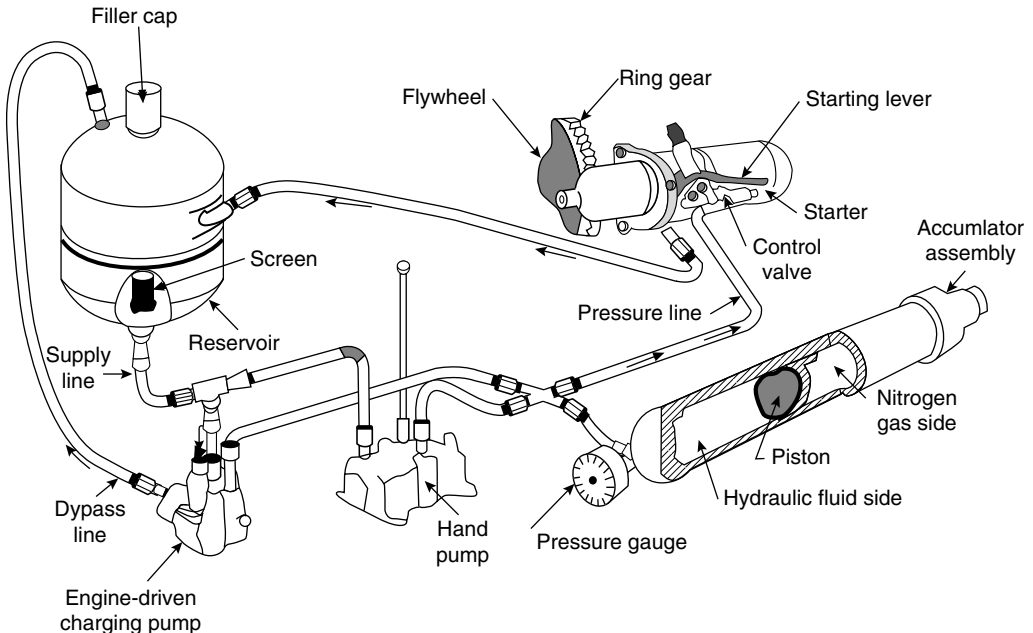

Fig. 13.16 Hydraulic Starting System

4. Starting by auxiliary engine

In this method, a small petrol engine is connected to the main engine through clutch and gear arrangement. The clutch is disengaged and the petrol engine is started by hand. Then the clutch is gradually engaged and the main engine is cranked for starting. Clutch is disengaged automatically when the main engine is started.

13.8 COOLING AND LUBRICATION SYSTEM FOR THE DIESEL ENGINE

Cooling and lubrication systems form an essential component of diesel engine plants. An efficient cooling and lubrication system not only improves the plant efficiency, but also ensures longer plant life. Given its importance, both of these systems are discussed hereunder.

13.8.1 Engine Cooling System

During the process of converting the thermal energy to mechanical energy, high temperatures are produced in the cylinders of the engine as a result of combustion. A large portion of heat from the products of combustion is transferred to the cylinder head and walls, piston and valves. This excess heat if not carried away by an efficient cooling system will damage the engine.

Necessity of engine cooling: Engine cooling is necessary for the following reasons:

- (i) The maximum operating temperature of lube oil ranges from 160°C to 200°C. If the temperature exceeds this limit, lube oil deteriorates and even might evaporate or burn. This may result in damaging of piston and cylinder surfaces or piston seizure.
- (ii) Due to higher engine temperature, the strength of the materials used for various engine parts decreases. This may result in excessive thermal stresses due to uneven expansion of various engine parts and result in *cracking*.
- (iii) Hot engine parts result in hot exhaust valve, which causes pre-ignition and knocking.
- (iv) Due to higher engine temperature, volumetric efficiency and power output of the engine reduces.

Two basic systems used for cooling the engine are

1. Air cooling

In this system, atmospheric air is circulated around the engine cylinder to dissipate the excess heat. Heat transfer area is increased by providing fins on the cylinder and cylinder head and air is passed over them. Air cooling is used for small engines and aircraft engines. Using the fins increases the heat transfer surface by about 5–10 times its initial value. Figure 13.17 shows a sectional view of an engine cylinder using fins. As maximum temperature exists near the exhaust valve and cylinder head, more fins are required here to dissipate heat.

The fins may be cast integral with the cylinder and cylinder head or may be fixed separately to the cylinder block. The number of cast fins may be 2–4 in number per centimetre or 4–6 fins per centimetre in case of machined fins. The spacing between the fins is limited to 2–5 mm and height of the fin varies from 20 to 50 mm.

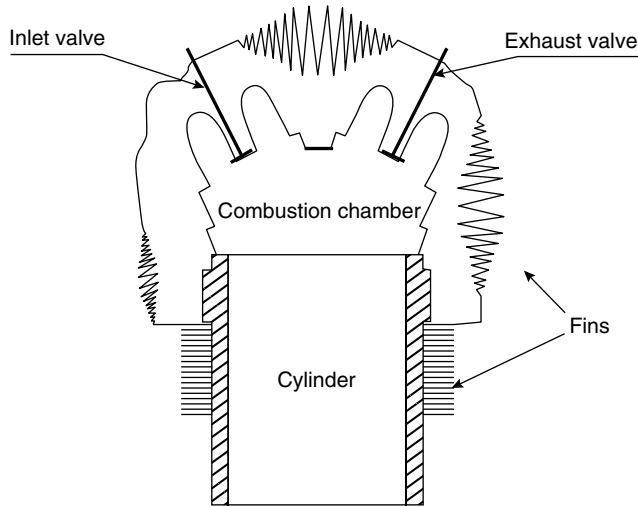

Fig. 13.17 Air Cooling System

2. Water cooling

In this system, the cylinder and cylinder head are enclosed in a water jacket. The water jacket is connected to a radiator or heat exchanger normally at the front end of the vehicle. Water is made to circulate through the water jacket, which cools the engine. The hot water returns to the radiator where it exchanges heat with atmospheric air. The cold water is again re-circulated.

Water cooling is used for bigger engines such as cars, buses, trucks, etc.

High operating temperature existing in the engine may disintegrate the lube oil film on the cylinder liners resulting in warping of valves and piston seizer, if the engine is not cooled properly. Thus, proper cooling of the engine is necessary to increase engine life. This is done by controlling the exit temperature of cooling water. If the exit temperature is too low, lube oil will not spread over the piston and the cylinders resulting in wear and tear. If it is too high, the lube oil burns and disintegrates. The exit temperature of cooling water is thus limited to 70°C. As constant flow rate of cooling water increases the exit temperature of cooling water with increased load, flow regulation of water is desirable to control the same.

The hot jacket water from the engine is passed through the coolers (hot well) where it is cooled with the help of raw water. The raw water is cooled in the cooling towers using either natural draft or forced draft air circulation. The sensible heat of water is transferred to air. In addition, the latent heat of evaporation of water vaporized is the main source of heat transfer. The degree of cooling action is limited by the vapour that can be absorbed before the air reaches saturation humidity at its leaving temperature. As the circulation of water is concerned, the cooling systems are generally divided into two types.

(i) Open- or single-circuit system

In this system shown in Figure 13.18, pump draws water from cooling pond and forces it into the main engine jackets. Water, after circulating through the engine, returns to the cooling pond. The engine jacket is subjected to corrosion because of the dissolved gases in the cooling water.

Figure 13.19 shows a closed or double circuit system.

(ii) *Closed- or double-circuit system*

In this system, raw water is made to flow through a heat exchanger when it takes up the heat of jacket water and returns back to the cooling pond or tower.

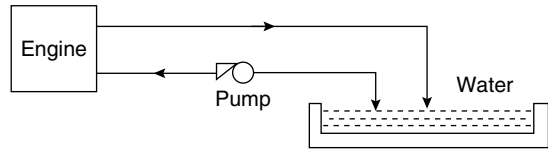

Fig. 13.18 *Open- or Single-Circuit System*

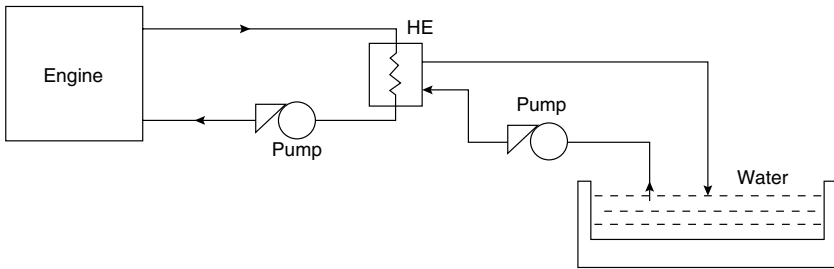

Fig. 13.19 *Closed- or Double-Circuit System*

About 25–35 per cent heat is lost by cooling water, which is known as jacket water loss. The rate of flow of water should be adjusted to maintain outlet cooling water temperature to 60°C and rise in temperature of cooling water is limited to 11°C. Water used for cooling should be free from impurities. Even though cooling by water is uniform, it poses a problem in cold weather. Cooling efficiency is reduced due to scaling in pipes, jackets and radiator. Engine efficiency is affected as some power is utilized to drive the water pump and radiator fan. This type of cooling system eliminates internal jacket corrosion, but the corrosion may exist in the raw water circuit.

13.8.2 Lubrication System

Due to the presence of friction, wear and tear of the engine parts takes place reducing the engine life. The lubricant introduced forms a thin film between the rubbing surfaces and prevents metal to metal contact. The various parts that require lubrication are cylinder walls and pistons, crank pins, gudgeon pins, big end and small end bearings, etc. The maintenance of proper lubrication system for all moving parts is an important problem in the operation of an IC engine.

The purpose of lubrication are (i) to reduce the power required to overcome friction, (ii) to increase the power output and (iii) to increase the engine life. Improper lubrication results in the breakdown of the lubricating films, causing piston seizure and serious damage to the engine.

Two basic systems used for engine lubrication are as follows:

1. *Wet sump*

In the wet sump system, the bottom of the crankcase contains an oil pan or sump which serves the purpose of an oil supplying tank or reservoir tank, or oil cooler. Oil dripping from the cylinders and bearings flows by gravity back into the wet sump where it is picked up by a pump and re-circulated through the engine lubrication system (Figure 13.20).

The types of wet sump systems generally used are (i) splash and circulating pump (force feed) system, (ii) force-feed system and (iii) full force-feed system.

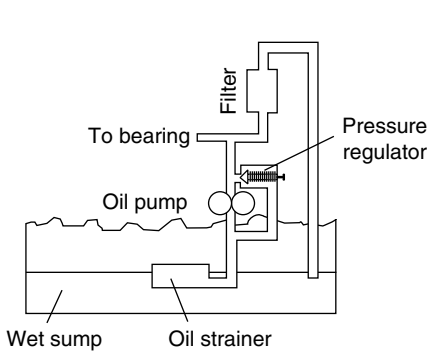

Fig. 13.20 Wet Sump Lubrication System

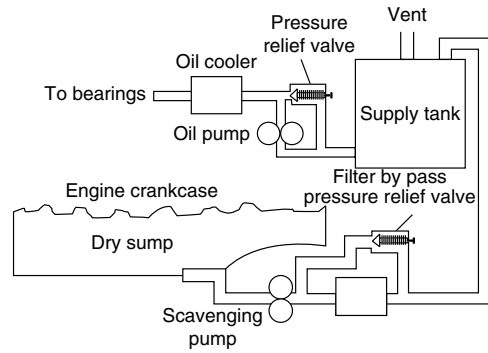

Fig. 13.21 Dry Pump Lubrication System

2. Dry sump

In this dry sump system, oil is supplied from an external tank. Oil drips from the cylinders and bearings into the sump. Oil is removed from the sump and passed back to the external tank through a filter. As the sump pump capacity is greater than oil pump capacity, oil is prevented from accumulating in the engine base (Figure 13.21).

Lubrication may be achieved in different forms: Full pressure lubrication, mechanical, force feed lubrication or gravity circulation from an overhead tank. Some of the lubrication systems are explained below.

(i) *Splash and force-feed lubrication system*

In a splash and force-feed lubrication system (Figure 13.22), oil is delivered to some parts by means of splashing and other parts through oil passages under pressure from the oil pump. In this system, the oil from the pump entering the oil galleries flows to the main bearings and camshaft bearings. The main bearings have oil-feed holes or grooves that feed oil into drilled passages of the crankshaft. The oil flows through these passages further to the connecting rod bearings and from there through holes drilled in the connecting rods to the piston-pin bearings.

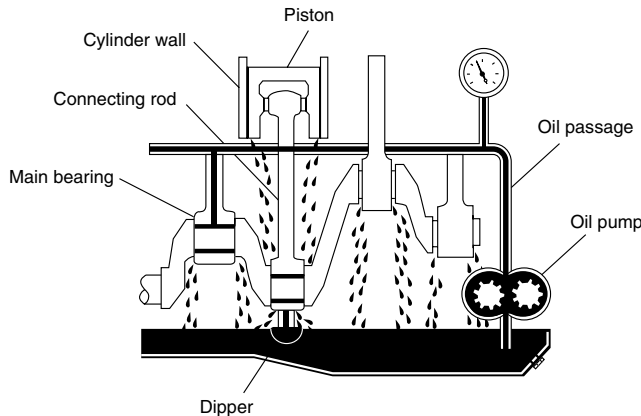

Fig. 13.22 Splash and Force-Feed Lubrication System

Cylinder walls are lubricated by splashing oil thrown off from the connecting-rod bearings. In some engines, small troughs are provided under each connecting rod that are kept full by small nozzles, which deliver oil under pressure from the oil pump. As engine speed increases, these oil nozzles deliver an increasingly heavy stream, powerful enough to strike the dippers directly. This generates a much heavier splash so that adequate lubrication of the pistons and the connecting-rod bearings is provided. In an overhead valve engine, the upper valve train is lubricated by pressure from the pump.

(ii) *Force-feed lubrication system*

In a force-feed lubrication system (Figure 13.23), oil is forced by the oil pump from the crankcase to the main bearings and the camshaft bearings. Unlike the *splash and force-feed lubrication system*, the connecting-rod bearings are also fed oil under pressure from the pump.

Oil passages drilled in the crankshaft lead oil to the connecting-rod bearings. The passages deliver oil from the main-bearing journals to the rod-bearing journals either through holes or through annular grooves. The holes line up once for every crankshaft revolution. In the case of annular grooves in the main bearings, oil can be fed constantly into the hole in the crankshaft.

The pressurized oil that lubricates the connecting-rod bearings also lubricates the pistons and walls by squirting out through strategically drilled holes. This lubrication system is used in all engines that are equipped with semi-floating piston pins.

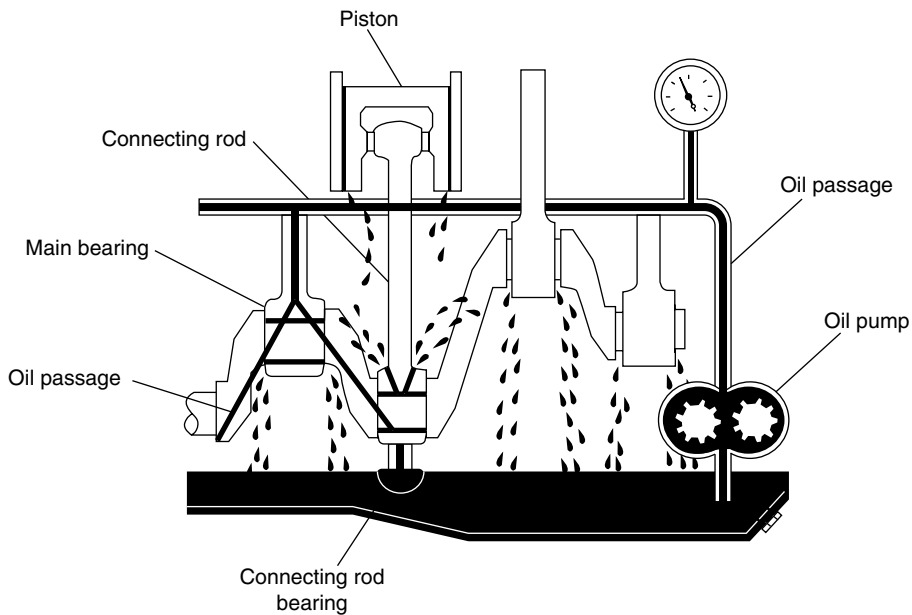

Fig. 13.23 Force-Feed Lubrication System

(iii) *Full force-feed (pressure) lubrication system*

In a full force-feed lubrication system, an oil pump supplies lubricating oil to many parts of the engine through duct system and to the crank shaft through drilled holes. The cylinder walls are

lubricated by oil mist that is slung outward from the connecting rod bearings or by splash of rod ends into oil pools. This system lubricates the main bearings, rod bearings, camshaft bearings and the complete valve mechanism. In addition, lubrication of the pistons and the piston pins is also enabled under pressure by holes drilled throughout the length of the connecting rod, creating an oil passage from the connecting rod bearing to the piston pin bearing. This passage not only feeds the piston pin bearings but also provides lubrication for the pistons and cylinder walls. This system is used in all engines that are equipped with full-floating piston pins (Figure 13.24).

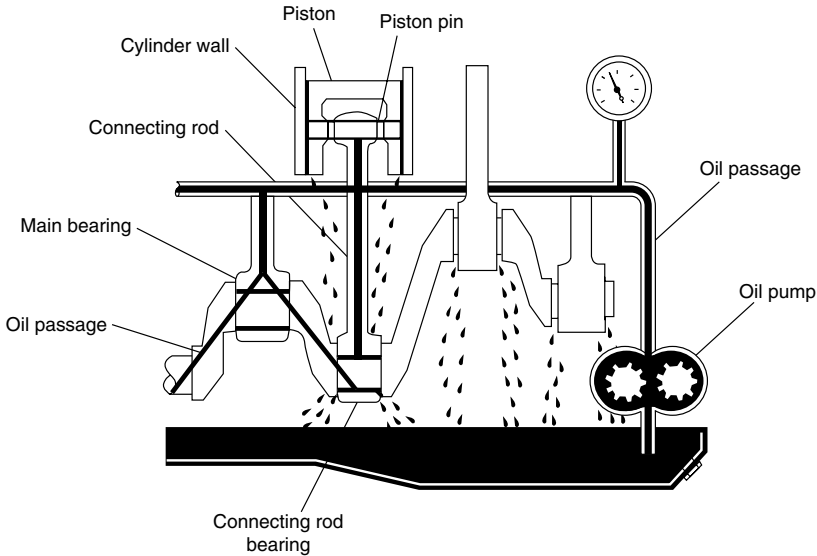

Fig. 13.24 Full Force-Feed (Pressure) Lubrication System

13.8.3 Filters, Centrifuges and Oil Heaters

1. Filters

The air cleaner or filter filters the incoming air. It also muffles the resonance (i.e. dampens the noise) of the swirling incoming air. The location of the air cleaner depends on the available space and the hood design.

An air filter performs the following functions:

- (i) It filters incoming air and removes impurities present in it.
- (ii) During back firing of the engine, it acts as a flame arrester.
- (iii) It acts as a silencer for the carburetion system by reducing the engine induction noise.

The filters used may be classified depending on the dust type and dust concentrations in the air.

(i) Oil impingement type

It consists of a frame filled with crimped (pressed into small folds or corrugated) wire or metal shavings (thin particles). These are coated with a special oil so that air passing through the

frame breaks up into smaller filaments when it comes into intimate contact with the oil. The oil can seize and hold any dust particles being carried by air. The efficiency of this filter drops progressively when in service. Hence, it should be refreshed periodically by removing, washing and re-oiling.

(ii) *Oil-bath type*

In this type of cleaner, the air is swept over or through a pool of oil. The dust particles become coated to the oil. The air is then passed through the filter, which retains the oil-coated dust particles. Figure 13.25 shows an oil bath-type oil filter containing a filter element saturated with oil. Oil is contained in a separate oil pan. Air from the atmosphere enters through the circumferential gap 1 and takes a turn at corner 2. This movement leaves large particle impurities present in air. Air then passes over the filter element through the oil surface. The clean air then passes through the passage 3.

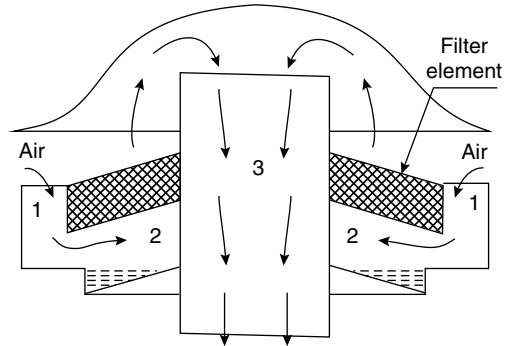

Fig. 13.25 Oil Bath-Type Air Cleaner

(iii) *Dry type*

It is made up of cloth, felt, glass, wool, etc. The filters catch dirt by causing it to cling to the surface of the filter material. The capacity of such filters drops progressively when they are in use. The cleaning is done based on the amount of air used by the engines and dust concentrations in it.

Figure 13.26 shows a light duty air cleaner. It consists of a bonded cylindrical cleaning element made of cellulose fibre material placed over a fine mesh screen that provides strength. The sides of the element are sealed against dust. Air passes through the element leaving any impurities present outside it.

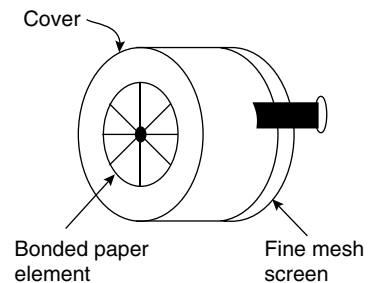

Fig. 13.26 Light Duty Air Cleaner (Dry)

2. *Centrifuges and oil heaters*

The complete lubrication system usually includes the following auxiliaries: Pump, oil cleaners, oil coolers, storage and sump tanks, gauges and safety devices. As oil passes through the lubrication cycle, it accumulates impurities in the form of carbon particles, water and metal scrap. For continuous reliable operation, attention should be given to oil cleaning.

For this purpose, filters with centrifuges or chemical action have been employed. Mechanical filters include cloth bags, wool, felt pads, paper discs and cartridge of porous material.

Rough cleaning of oil can be done by passing high-speed centrifuges for final cleaning. Centrifuging can be done by periodic centrifuging of the entire lubricating oil or by continuous cleaning of a small fraction of it by splitting the oil from main flow and returning back to the main stream. Oil should be heated before passing it through the centrifuge.

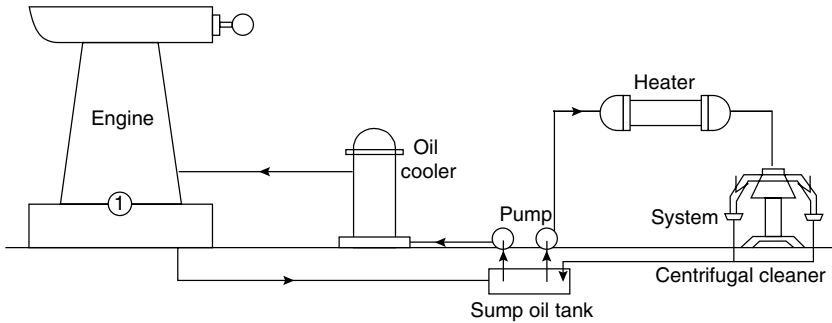

Fig. 13.27 Continuous Centrifuging System

Oil should be cooled before supplying it to the engine. As heat is developed due to friction between the moving parts, the cooling is done by using water from the cooling tower (Figure 13.27).

13.9 INTAKE AND EXHAUST SYSTEMS

Intake and exhaust systems used in diesel engines ensure smooth functioning of the engine. As diesel engines draw in air only, speed and power are controlled by the amount of fuel injected at the end of the compression stroke. For two-stroke diesel engines, a blower is used for induction of air and to improve scavenging. An exhaust system must reduce engine noise and discharge exhaust gases safely away from the engine. An efficient exhaust system can improve engine performance. Both these systems and their essential components are discussed in this section.

13.9.1 Intake System

The primary components of the automotive intake system are Intake manifold, throttle body and air induction components such as air cleaner and ducting.

The intake manifold is normally made of an aluminium alloy and is attached to the cylinder head. Its construction and design depends on its application. The intake manifold can accommodate a throttle body Injection unit and the mixing of the air/fuel mixture is done at the manifold base. The butterfly shaft connected to the throttle cable controls the airflow through the unit.

The air induction components consist of an air cleaner and housing, solid and flexible-duct tubing, and connectors. The air induction system draws in ambient air from the atmosphere. The inlet opening may be located in various positions under the hood.

1. Air cleaner

The air cleaner filters the incoming air. The air cleaner element may be manufactured from pleated paper, oil impregnated cloth or felt, or in an oil bath configuration. Another function of the air cleaner is to muffle the resonance (i.e. dampen the noise) of the swirling incoming air. The location of the air cleaner depends on the available space and the hood design.

2. Ducting

The ducting can be made of hardened plastic with flexible rubber couplings to absorb engine movement. These are usually secured in place by metal worm drive clamps.

Figure 13.28 shows a typical intake system of a diesel engine plant. A large diesel engine plant requires about $0.076 \text{ m}^3/\text{min}$ to $0.11 \text{ m}^3/\text{min}$ of air per kW of power developed. Air contains a lot of dust, hence if it is necessary to remove the dust content in the atmospheric air. The air system contains an intake manifold located outside the building with a filter to catch dirt that would otherwise cause excessive wear in the engine. If the atmospheric temperature is too low, engine misfires at low loads and hence it is necessary to install a heating element using exhaust gas. Occasionally, engine noise may be transmitted back through the air intake system to the outside air. In such cases, a silencer is provided between the engine the intake. It is a light weight steel pipe.

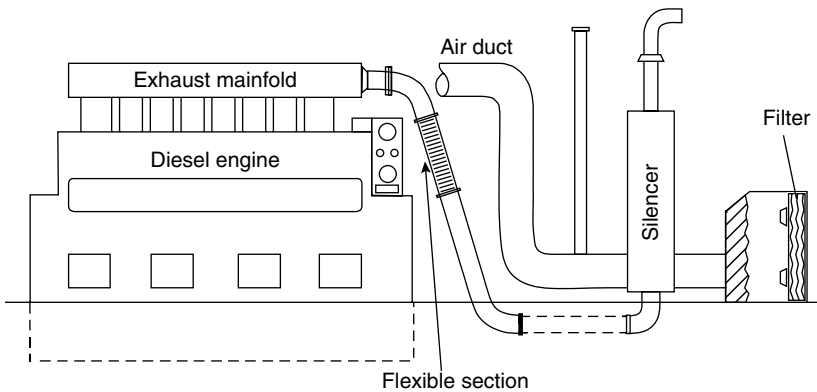

Fig. 13.28 Engine Intake System

13.9.2 Exhaust System

The primary components Figure 13.29 shows an engine exhaust system. The primary components of the exhaust system are exhaust manifold, engine pipe, catalytic converter, exhaust brackets, muffler and components such as the resonator and tail pipe.

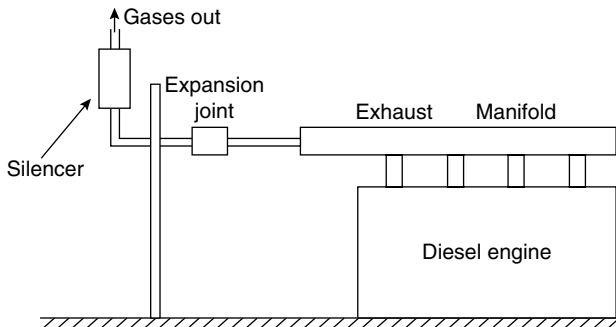

Fig. 13.29 Engine Exhaust System

The exhaust system generally handles approximately 0.23 m³/min to 0.30 m³/min of gases per kW developed at the average exhaust temperature. Muffling of the exhaust noise is done by using silencers located outside the building. They may be of CI, steel, etc. A pipe or stack will extend vertically from the silencer outlet to carry the exhaust gases.

The following provisions should be made for the exhaust system:

- (i) Silencing of the exhaust noise to the required degree.
- (ii) Discharge of the exhaust sufficiently high above the ground level.
- (iii) Water-cooled exhaust lines or special high-temperature materials for exhaust pipes.
- (iv) Modification to utilize the by-product heat.
- (v) Isolation of engine vibration from building and muffler system by using flexible section of the exhaust pipe.
- (vi) Arrangement of the exhaust system to minimize the back pressure created by the exhaust system itself.

13.10 APPLICATION OF DIESEL POWER PLANT, ADVANTAGES AND DISADVANTAGES

The diesel electric power plants mainly find application in the following fields:

1. *Peak load plant*

The diesel plants are used in combination with thermal or hydro-electric plants as peak load plants. This plant is used only during peak load plant operation, as it can be started quickly and it has no standby losses.

2. *Mobile plants or outdoor units*

Mobile diesel plants mounted on skids or trailers can be used for temporary or emergency purposes such as for supplying power to large civil engineering works for supplementing electricity supply systems that are temporarily short of power. Mobile plants also find application in various other industries such as film, etc.

3. *Standby units*

Diesel plants are also used as a standby unit to supply part load when required. For example, this can be used with hydro-plant as a standby unit. If the water available is not sufficient due to reduced rainfall, a diesel station supplies power in parallel with hydroelectric station. The use is made temporarily till the water is available to take the full load.

4. *Emergency plant*

The plants can be used for emergency purposes where they act as standby units, normally idle. Whenever there is power interruption, these units are used. For example, they are used in situations when power failure may lead to financial loss or danger in key industrial processes, tunnel lighting and operating rooms of hospitals. They are also used for telecommunication and water supply under emergency conditions.

2

Hydroelectric Power Plant

2.1 INTRODUCTION

Hydroelectricity is the term referring to electricity generated by hydropower; the production of electrical power through the use of the gravitational force of falling or flowing water. It is the most widely used form of renewable energy, accounting for 16 percentage of global electricity generation.

Most hydroelectric power comes from the potential energy of dammed water driving a water turbine and generator. The power extracted from the water depends on the volume and on the difference in height between the source and the water's outflow. This height difference is called the head. The amount of potential energy in water is proportional to the head. A large pipe (the "penstock") delivers water to the turbine.

"Run of the river" systems do not require a dam or storage facility to be constructed. Instead they divert water from the stream or river, channel it in to a valley and drop it in to a turbine via a pipeline called a penstock. The turbine drives a generator that provides the electricity to the local community. By not requiring an expensive dam for water storage, run-of-the-river systems are a low-cost way to produce power. They also avoid the damaging environmental and social effects that larger hydroelectric schemes cause, including a risk of flooding. Water from the river is channeled through a settling basin, which helps to remove sediment that could harm the turbine. The water then flows into the Fore bay Tank where it is directed downhill through a pipe called a penstock. When the water reaches the bottom, it drives a specially designed turbine to produce the electricity.

Hydroelectric power plants are the most efficient means of producing electric energy. The efficiency of today's **hydroelectric plant** is about 90 percentage.

2.2 CLASSIFICATIONS

Based on the Rating of the Plant

This is the main consideration while assigning a category to a power plant. The rating of the plant will work as the name of the plant especially in case of hydropower plant. Based on rating plants are classified as:

- **Micro hydro power plant:** If the rating of the plant or we can say the output of the plant is less than 100 kW or 0.1 MW, the plant is called Micro Hydro Power Plant.
- **Mini hydro power plant:** If the rating of the plant or we can say the output of the plant is more than 100 kW or 0.1 MW and is less than 1 MW, the plant is called Mini Hydro Power Plant.

- **Small hydro power plant:** If the rating of the plant or we can say the output of the plant is less than 10 MW, the plant will come under the Category of Small Hydro Power Plant. According to the new classification of CEA, India small hydro power plant may have rating up to 25 MW.

Based on the Technology Used

Based on the technology involved specially during the construction of dam and height of the dam and demand the hydro power plants are again classified into three categories. These are:

- **Impoundment hydro power plant:** It is the most common type of hydro power plant based on technological classification. A dam is constructed and water is stored behind dam and the stored potential energy of water behind dam is used as fuel for hydro power plant.
- **Diversión hydro power plant:** In case the water head is small and the potential energy of water is not enough to drive a turbine then a separate water flow is taken from river with high speed so that it may produce enough current in the generator.
- **Pumped hydro power plant:** Sometimes when the demand of power supply is not high then produced electricity is used to drive a motor and water is pumped back to the dam and the potential energy of this water is used to generate the electricity at the plant.

Based on Load Sharing by Hydro Power Plant

- **Peak load power plant:** These types of power plant supply power to the load when there peak load period, only. Rest of the time the power is supplied by main plant. In this types of plants a main power plant is always required and hydro power plant work as secondary plant in this case and share the load for two or three hours.

Let we have a power plant with real load 120 MW for a period of one hour and rest of the time the load remains within a limit upto 90 MW. In this case installing a main plant of 90 MW with a support hydropower plant of capacity 35 MW is a good idea to save money on construction of main plant.

- **Base load hydro power plant:** This is the power plant which work independently and supply power to the whole load. It work for the whole time *i.e.*, It supply power when there is a requirement. This type of plant are installed where huge water is available.

Based on the availability of head

- (i) High head power plants (head > 100 m)
- (ii) Medium head power plants (30 m to 100 m)
- (iii) Low head power plants (head < 30 m)

Based on the quality of water available

- (i) Run-of-river plant without pondage.
- (ii) Run-of-river plant with pondage.
- (iii) Plant with storage reservoirs.
- (iv) Pumped storage plants.
- (v) Mini and micro hydro plants.

2.3 LAYOUT OF HYDROELECTRIC POWER PLANT

Hydroelectric power plants convert the hydraulic potential energy from water into electrical energy. Such plants are suitable where water with suitable *head* are available. The layout

(Figure 2.1) covered in this article is just a simple one and only cover the important parts of hydroelectric plant. The different parts of a hydroelectric power plant are:

1. **Water reservoir:** It stores the water received from the catchment areas during monsoon period. Water surface in the storage reservoir is known as head race.

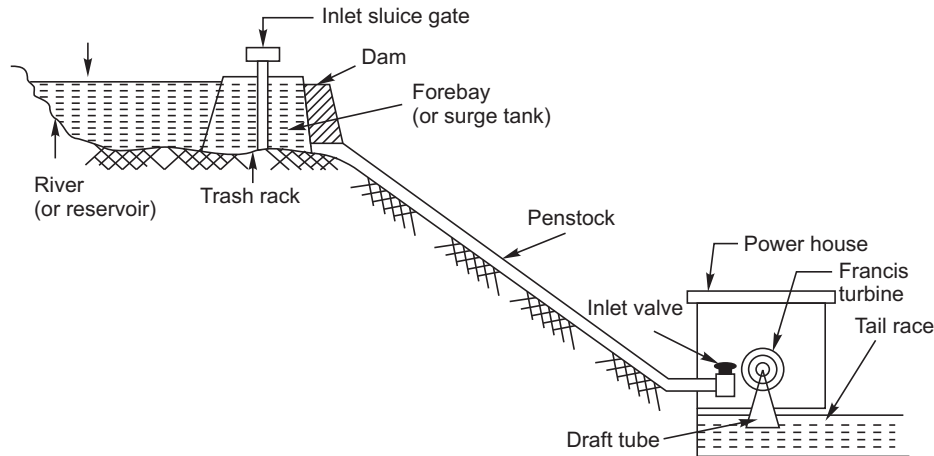

Fig. 2.1. Layout of Hydroelectric Power Plant

2. **Dam:** Dams are structures built over rivers to stop the water flow and form a reservoir. The reservoir stores the water flowing down the river. This water is diverted to turbines in power stations. The dams collect water during the rainy season and stores it, thus allowing for a steady flow through the turbines throughout the year. Dams are also used for controlling floods and irrigation. The dams should be water-tight and should be able to withstand the pressure exerted by the water on it. There are different types of dams such as arch dams, gravity dams and buttress dams. The height of water in the dam is called head race.
3. **Spill way:** A spillway as the name suggests could be called as a way for spilling of water from dams. It is used to provide for the release of flood water from a dam. It is used to prevent over topping of the dams which could result in damage or failure of dams. Spillways could be controlled type or uncontrolled type. The uncontrolled types start releasing water upon water rising above a particular level. But in case of the controlled type, regulation of flow is possible.
4. **Pressure tunnel:** It carries water from the reservoir to surge tank.
5. **Pen stock and tunnel:** Penstocks are pipes which carry water from the reservoir to the turbines inside power station. They are usually made of steel and are equipped with gate systems. Water under high pressure flows through the penstock. A tunnel serves the same purpose as a penstock. It is used when an obstruction is present between the dam and power station such as a mountain.
6. **Surge tank:** Surge tanks are tanks connected to the water conductor system. It serves the purpose of reducing water hammering in pipes which can cause damage to pipes. The sudden surges of water in penstock is taken by the surge tank, and when the water requirements increase, it supplies the collected water thereby regulating water flow and pressure inside the penstock.
7. **Power station:** Power station contains a turbine coupled to a generator. The water brought to the power station rotates the vanes of the turbine producing torque and rotation

of turbine shaft. This rotational torque is transferred to the generator and is converted into electricity. The used water is released through the *tail race*. The difference between head race and tail race is called gross head and by subtracting the frictional losses we get the net head available to the turbine for generation of electricity.

8. **Draft tube:** It is connected to the outlet of the turbine. It allows the turbine to be placed over tail race level.
9. **Tail race:** It is a water way to lead the water discharged from the turbine to the river.
10. **Step up transformer:** It is used to raise the voltage of the electrical power generated at the **generator terminal**.

2.4 DAMS

A dam is a man-made structure built across a river. Most dams are built to control river flow, improve navigation, and regulate flooding. However, some dams are built to produce hydroelectric power.

Hydroelectric power is produced as water passes through a dam, and into a river below. The more water that passes through a dam, the more energy is produced. Once a dam is built, an artificial man-made lake is created behind the dam.

Electricity is produced by a device called a turbine. Turbines contain metal coils surrounded by magnets. When the magnets spin over the metal coils, electricity is produced. Turbines are located inside dams. The falling water spins the magnets.

Dams provide clean, pollution free energy, but they can also harm the environment. Species that use rivers to spawn are often hurt by dams. In the Northwest, sockeye salmon and trout populations have dropped from 16 million to 2.5 million since hydroelectric plants were built on the Columbia River. Dams all over the world have hurt some species.

Types of Dams

- (i) Based on their functions, dams can be classified as
 - (a) Storage dams
 - (b) Diversion dams
 - (c) Detention dams
- (ii) Based on the shape, the dams are classified into
 - (a) Trapezoidal dams
 - (b) Arch dams
- (iii) Based on the materials of construction
 - (a) Earth dams
 - (b) Rock pieces dam
 - (c) Stone masonry dams
 - (d) Concrete dams
 - (e) RCC dams
 - (f) Timber and rubber dam
- (iv) Based on hydraulic design
 - (a) Overflow type dam
 - (b) Non-overflow type dam
- (v) Based on structural design
 - (a) Gravity dam
 - (b) Arch dam
 - (c) Buttresses dam

2.5 SELECTION OF WATER TURBINES

The major problem confronting the engineering is to select the type of turbine which will give maximum economy. The hydraulic prime-over is always selected to match the specific conditions under which it has to operate and attain maximum possible efficiency.

The choice of a suitable hydraulic prime-mover depends upon various considerations for the given head and discharge at a particular site of the power plant. The type of the turbine can be determined if the head available, power to be developed and speed at which it has to run are known to the engineer beforehand.

The following factors have the bearing on the selection of the right type of hydraulic turbine which will be discussed separately:

1. Rotational Speed
2. Specific Speed
3. Maximum Efficiency
4. Part load Efficiency
5. Head
6. Type of Water
7. Runaway Speed
8. Cavitation
9. Number of Units
10. Overall cost

The hydraulic power of a plant can be calculated using following expression

$$P = g \rho QH$$

where, P is the hydraulic energy in Watts

g is acceleration due to gravity (9.81 m/s^2)

ρ is water density (1000 kg/m^3)

Q is the flow (or) discharge m^3/s

H is the height of fall of water or head in meter

The electric power produced in kWh.

$$\begin{aligned} W &= 9.81 \times 1000 \times Q \times H \times \eta \times t \\ &= 9.81 Q H \eta t \end{aligned}$$

where, t is the operating time in hours (8760 hours/year)

η is the efficiency of the turbine-generator (0.5 to 0.9)

The power developed depends upon the quantity of water (Q) and the head (H) of water.

Advantages of Hydropower plant

1. Water source is perennially available.
2. Running cost is very low.
3. Non-polluting.
4. Power generation can be switched on and off in a very short time.
5. Simple in concept and self-contained in operation.
6. Greater reliability.
7. Greater life (more than 50 years).
8. Other than power generation, it provides irrigation, flood control, afforestation navigation and aqua-culture.
9. High efficiency.
10. Suitable for spinning reserve.
11. Man power requirement is low.
12. Simple in design and operation.

Disadvantages of Hydropower

1. High capital investment and low rate of return.
2. Gestation period is very large.
3. Power generation depends on availability of water.
4. Plants are far away from load centre hence cost of transmission and losses are high.
5. Large hydro plants disturb the ecology of the area due to deforestation.

2.6 FACTORS TO BE CONSIDERED WHILE SELECTING THE SITE FOR HYDROELECTRIC POWER PLANT

1. Availability of water and water head.
2. Accessibility of site.
3. Water storage capacity.
4. Distance from the load centre.
5. Type of land.

2.7 PUMPED-STORAGE PLANTS

Pumped storage systems work using two reservoirs that are built at differing heights. During periods of peak demand, energy is generated by releasing water from the upper reservoir to drive turbines. The water is pumped back up to the upper reservoir from the lower reservoir during periods of low energy demand.

A pumped-storage plant has two reservoirs:

Upper reservoir: Like a conventional hydropower plant, a dam creates a reservoir. The water in this reservoir flows through the hydropower plant to create electricity.

Lower reservoir: Water exiting the hydropower plant flows into a lower reservoir rather than re-entering the river and flowing downstream.

Using a **reversible turbine**, the plant can pump water back to the upper reservoir. This is done in off-peak hours. Essentially, the second reservoir refills the upper reservoir. By pumping water back to the upper reservoir, the plant has more water to generate electricity during periods of peak consumption.

